



Automatic Air Dehydrator with Ethernet Communications for Outdoor & Mobile Applications

MODEL ADH[®] NETCOM[™] NEMA

FEATURES & BENEFITS

- Provides dry pressurized air to ensure signal quality of antenna waveguide and dielectric coaxial cable
- Highly configurable to meet the needs of wide ranging applications
- Programmable operating pressure range: 0.10 psig - 7.50 psig (7mbar - 517mbar)
- Brushless compressor for long life
- Future-proof software based features allow updates and upgrades while in service
- Remote monitoring and control with web interface or SNMP
- Configurable Master/Slave operation
- Ethernet, RS-422/485, RS-232 and alarm relay outputs
- Durable, light weight IP66, NEMA 4X enclosure
- Designed to allow minimal flex without damaging enclosure or components for mobile and other high vibration applications
- Optionally available with military style connectors
- Low energy use minimizes operational costs

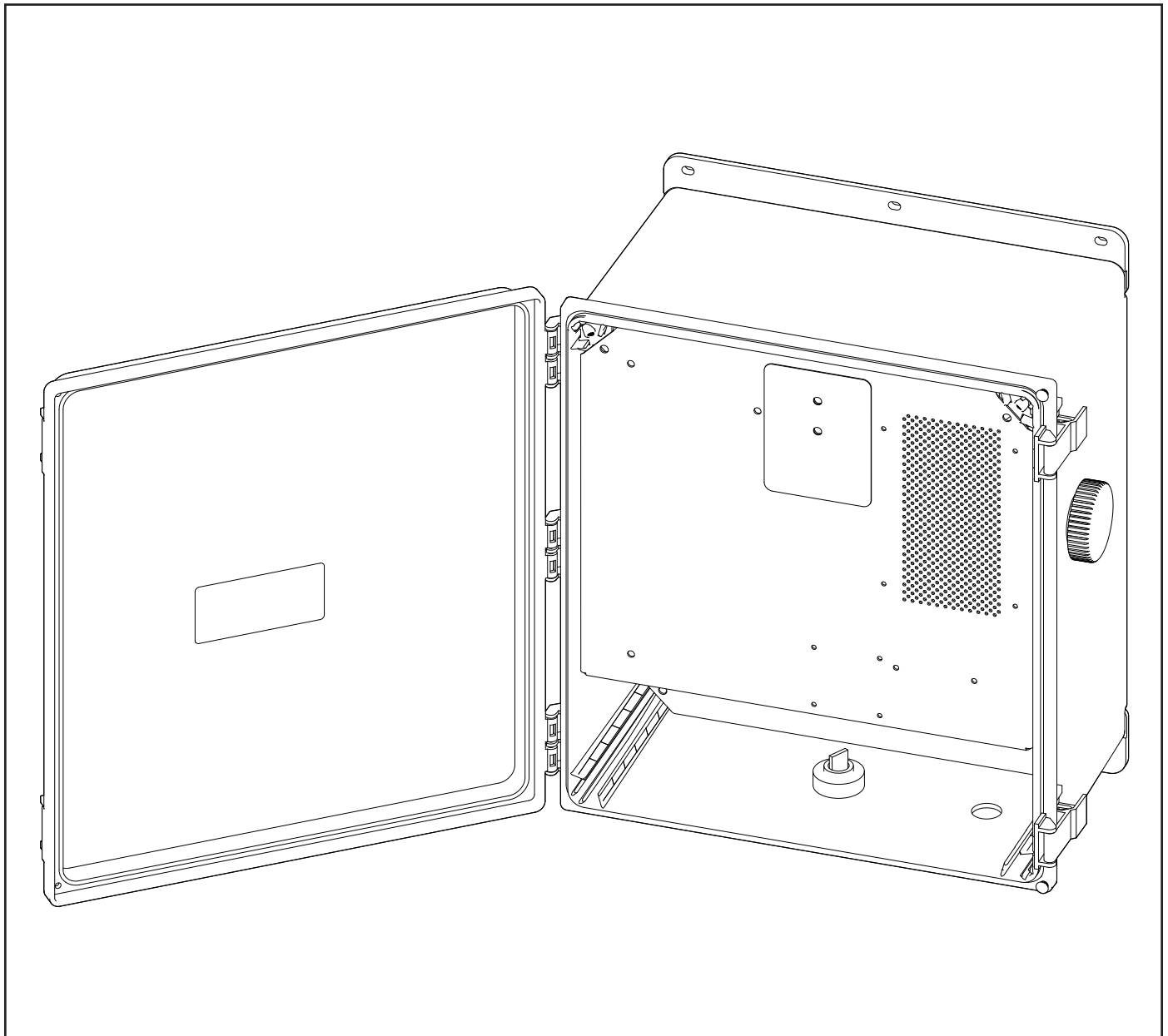

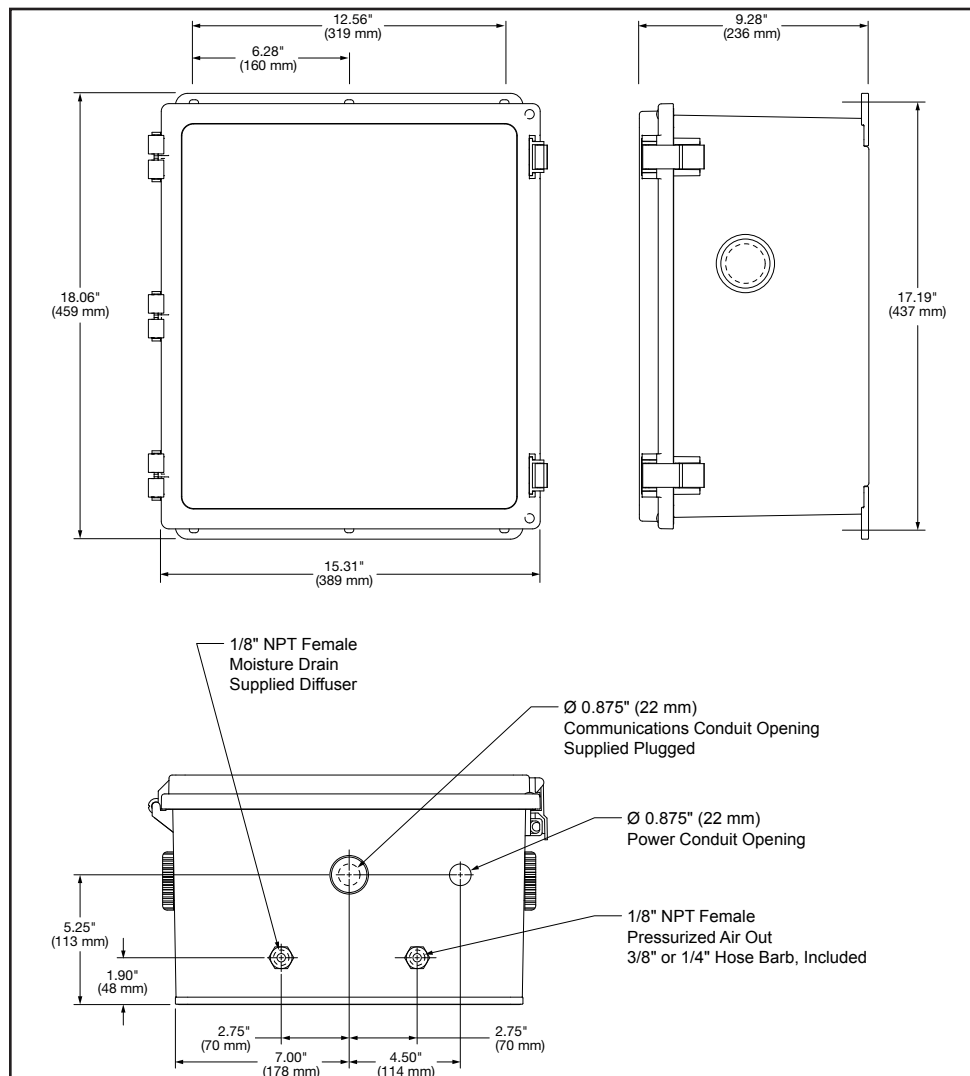

DESCRIPTION

The ADH NETCOM automatic dehydrator supplies low pressure dry air to keep waveguide and coaxial cable dry. Output pressure is configurable from 0.10 psig to 7.50 psig (7mbar to 517mbar) in 0.01 psig (0.67mbar) increments. Factory default pressure is 0.5 psig (34.5mbar). Operational monitoring and alarms are software based making them highly configurable in the field. Future software features can be installed while in service over the internet or local Ethernet network.

The ADH NETCOM automatic dehydrator is Ethernet network ready. Units can be configured and monitored using either built in SNMP support or the web interface. Legacy system support is provided via RS-422/485 or RS-232

interfaces. Three programmable alarm relays are also included. Communicated operational information includes output pressure, duty cycle, temperature, compressor hours and air drying canister status.

The ADH NETCOM automatic dehydrator uses a brushless dual-diaphragm pump for long life. Dehydrator operates with exceptionally low noise and vibration levels. The air drying canisters use aluminum oxide desiccant for high efficiency. The humidity sensor signals for regeneration based upon current dew point rather than at fixed time intervals for additional energy savings and long desiccant life.

The ADH NETCOM NEMA automatic dehydrator provides the same functionality as a standard ADH NETCOM in an environmentally

sheltered IP66, NEMA 4X enclosure. It is ideal for use with mobile satellite antenna installations and for outdoor mounting for pressurization systems localized to the antenna pedestal. This outdoor configuration is also ideal for use in pressurization systems in remote locations such as along rail lines, pipe lines and at power distribution substations. While the NEMA enclosure keeps out moisture, the temperature control system allows operation down to -40°F (-40°C). The ADH NETCOM NEMA automatic dehydrator weighs just 24 lbs (10.9 kg).

For complete information describing its application, installation and features, please contact Customer Service or check on the web at www.networketi.com.

SPECIFICATIONS

General

Approvals



Type 1950
Information Technology Equipment

Also evaluated by Underwriters Laboratories Inc.[®]
In accordance with IEC Publication 60950



Regeneration Method	Automatic, demand
Maximum dew point	-40° F/C

Enclosure

Type	Hoffman [®] POLYPRO [®] Polyester Type 4X
Cover Attachment	Hinged, lockable
Protection	IP66, NEMA 4X
Dimensions	15.31" × 18.06" × 9.28" (389mm × 459mm × 236mm)
Entries	1 × 0.88" (22mm) entry for supply power 2 × 0.63" (16mm) entry for dry pressurized air and condensate discharge
Weight	24 lbs (10.9 kg)
Mounting	Wall, post/pole or shelf mounted

Power

Supply	100-240 VAC, 50/60 Hz ±20-75 VDC
Maximum current	1.7 Amps @ 120 V
Power usage	150 W max.
Heat dissipation	512 BTU/hr max. @150 W

Output

Flow rate	25.4 scfh (12 lpm)
Maximum pressure	7.5 psig (517mbar)
Internal safety relief valve	8 psig (552mbar)
Discharge port	1/8" NPT 3/8" or 1/4" hose barb (both included)
Display units	SI (millibars); English (psig), default

Control

Protocols	HTTP (Web Interface), SNMP, UDP, TFTP
Maximum pressure	Configurable Range: 0.20 psig - 7.5 psig (14mbar - 517mbar), Default: 0.50 psig (34.5mbar)
Minimum pressure	Configurable Range: 0.10 psig - 7.4 psig (7mbar - 510mbar), Default: 0.30 psig (21mbar)
Low pressure alarm level	User Configurable, Default: 0.15 psig (10mbar)
High pressure alarm level	User Configurable, Default 1.5 psig (103.5mbar)
Alarm relays	Contact Type - Form C, SPDT, reverse acting Ratings - 0.25 Amps @ 60 V User Configurable, Defaults - Alarm Relay 1: Summary Alarm, Alarm Relay 2: Low Pressure Alarm, Alarm Relay 3: Over Pressure Alarm
Duty cycle alarm	User Configurable, Default: 50%
Master/Slave configuration	User Configurable, Default: Standard/Slave

Environmental

Operating temperature	-40°F to 130°F (-40°C to 55°C)
Storage temperature	-40°F to 150°F (-40°C to 60°C)
Cold Start	Pressurization will commence when internal temperature reaches 32°F (0°C) or above; 11 minutes at -4°F (-20°C)

ORDERING INFORMATION

Order Number	Description
23483	ADH NETCOM NEMA Automatic Dehydrator, 100-240 VAC
23589	ADH NETCOM NEMA Automatic Dehydrator, \pm 20-75 VDC
Type 1 Mil-Spec Connectors	
23740	ADH NETCOM NEMA Automatic Dehydrator, AC w/ Mil-Spec Connectors, Type 1
23742	ADH NETCOM NEMA Automatic Dehydrator, DC w/ Mil-Spec Connectors, Type 1
23739	Type 1 Mil-Spec Connector Accessory Kit (for 23483 & 23589)
Type 2 Mil-Spec Connectors	
23856	ADH NETCOM NEMA Automatic Dehydrator, AC w/ Mil-Spec Connectors, Type 2
23882	ADH NETCOM NEMA Automatic Dehydrator, DC w/ Mil-Spec Connectors, Type 2
23883	Type 2 Mil-Spec Connector Accessory Kit (for 23483 & 23589)



Digisat International Inc.

4195 W. New Haven Ave., Suite 15

Melbourne, FL 32904

USA

+1-321-676-5250

Email: sales@digisat.org

<http://www.digisat.org>

LIMITED WARRANTY

ETI's two year limited warranty covering defects in workmanship and materials applies. Contact Customer Service for complete warranty information.

DISCLAIMER

Environmental Technology, Inc. makes no representations or warranties, either expressed or implied, with respect to the contents of this publication or the products that it describes, and **specifically disclaims any implied warranties of merchantability or fitness for any particular purpose**. Environmental Technology, Inc. reserves the right to revise this publication, and to make changes and improvements to the products described in this publication, without the obligation of Environmental Technology, Inc. to notify any person or organization of such revisions, changes or improvements.

The ETI logo, We Manage Heat and ADH are registered trademarks of Environmental Technology, Inc. NETCOM is a trademark of Environmental Technology, Inc. Hoffman and POLYPRO are trademarks of Hoffman Enclosures Inc. Copyright © 2012 Environmental Technology, Inc. All rights reserved.