

Model C240MT Trailer Mounted Satcom Terminal

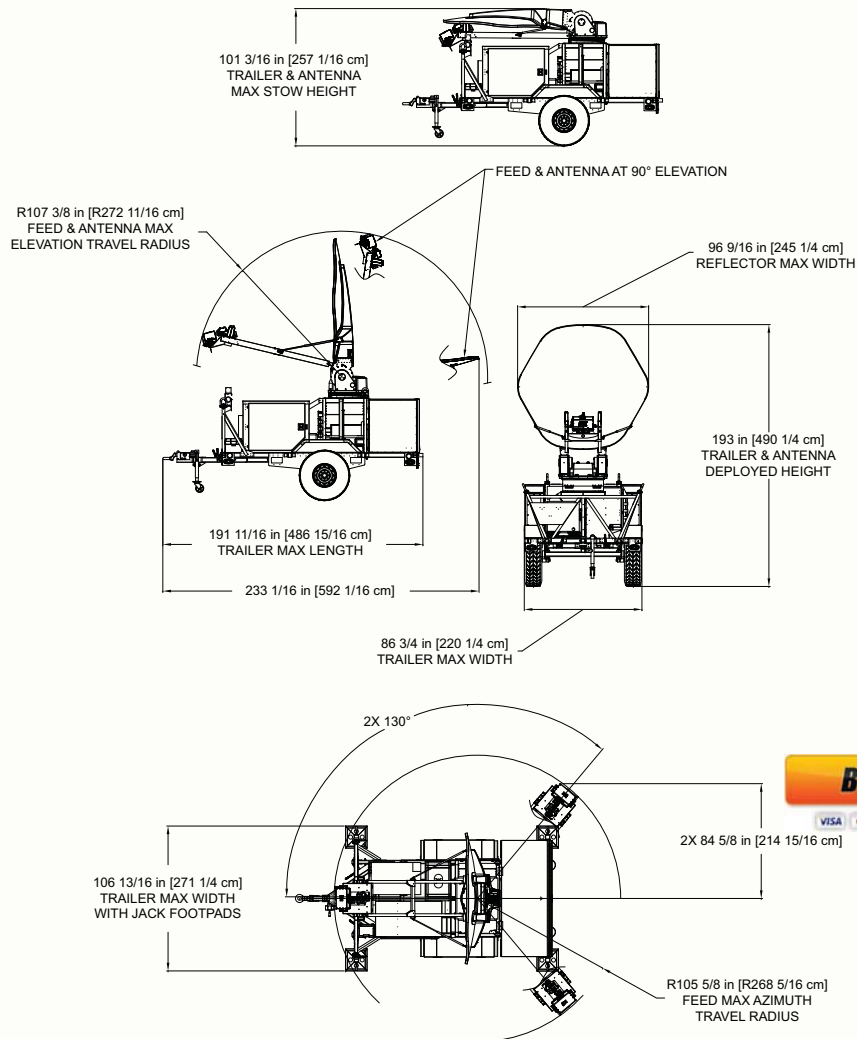

Model C240MT Trailer Mounted Satcom Terminal



Description

The General Dynamics SATCOM Technologies lightweight commercial 2.4-meter Trailer Mounted Satcom Terminal is designed for worldwide transmit and receive operation in C, X, Ku and Ka-band. This mobile terminal consists of a 2.4-meter tracking antenna mounted on a rugged chassis equipped with a generator and environmentally controlled rack enclosure. This configuration results in a low-weight tow package with superior features and high performance under wind-loading conditions. The accurate reflector surface provides exceptionally low sidelobe and cross-polarization performance well within INTELSAT and EUTELSAT requirements. The interchangeable feeds are palletized for quick, easy removal and replacement, allowing the end-user to effectively change frequency bands in the field within minutes. HPAs can be boom mounted for minimal WG losses per the customer's requirements. The onboard generator provides power to the UPS, ECU, and all the rack-mounted equipment located in the 38 rack-unit electronics enclosure. The entire terminal can be controlled through the M&C system as part of the 323T tracking controller (optional). The commercial 323T ACU provides auto-acquisition and several optional tracking algorithms including adaptive tracking in high winds.

Features

- Single offset carbon-fiber reflector
- High performance
 - Low sidelobes, high EIRP capability, compliant under operational wind conditions
- Stow/deployment
 - Low profile, stow position on vehicle, precision alignment, automatic deploy and stow
- INTELSAT type approved for C/Ku-band, EUTELSAT compliant
- Safety equipment, brakes, lights, pintle hitch

Options

- Reflector (single or three-piece segmented)
- Finishes (white or per customer spec)
- Integration (various TWT/amplifier mounting arrangements)
- Anti-icing
- Troposcatter capable
- ACU built-in M&C and spectrum analyzer
- Adaptive tracking
- HMMWV tires/wheels

The Strength to Perform

Full-featured auto-acquire tracking controller

Compact transit configuration for aircraft transit

Multiband antenna system with rapid interchange between C, X, Ku and Ku-band feeds

Motorized cable drive positioner

38 RU Electronics Enclosure Unit (EEU)

7.5 kW generator and 3 kW UPS

Model C240MT Trailer Mounted Satcom Terminal

Technical Specifications

Mechanical	
Travel	Az = ±130° continuous; El = 0 - 90° of reflector boresight; polarization = ±90°
EEU (Electronics Enclosure Unit)	2 each 19 rack units, weatherized access door
ECU (Environmental Control Unit)	9,000 BTU cooling, 1.9 kW heating
Reflector	2.4-meter carbon fiber (single or three-piece configuration)
Feed	Multiband interchangeable, C, X, Ku and Ka options including troposcatter
Finish	White (standard; other optional finishes also available)
Weight	4,000 lbs w/single feed + HPA (typical), GVW = 4,200 lbs
L x W x H ¹	192 in. x 97 in. x 102 in. stowed
Electrical Interface (Auto-transformer)	120/240 VAC 50/60 Hz shore power
Generator	7.5 kW, 120 VAC, 60 Hz, 24 gal. diesel tank
UPS	3 kW, 120 VAC, 60 Hz
Storage Cabinet	27 cubic foot weatherproof
Power Consumption	1 gal. diesel/hr., 2900 KVA + ECU (1.9 kW)
Chassis	Torsion axles, inertial brakes, safety lights, high-flotation tires, pintle hitch

Environmental	
Wind Loading	
Operational	45 mph (72 km/h) gusting to 60 mph (97 km/h)
Survival	60 mph (97 km/h) gusting to 80 mph (129 km/h) any position ² 90 mph (145 km/h) stow position
Pointing Loss (operational winds)	2.0 dB peak (Ka-band Rx), performance dependent on controller options and anchoring
Temperature	
Operational	-22° to +122° F (-30° to +50° C)
Survival	-40° to +158° F (-40° to +70° C)
Rain	Operational: 4 in/h (10 cm/h); Survival: 6 in/h (15 cm/h)
Relative Humidity	0% to 100% with condensation
Solar Radiation	360 BTU/h/ft ² (1000 Kcal/h/m ²)
Radial Ice (survival)	1 in (25 mm) on all surfaces, 1/2 in (12 mm) on all surfaces with 60 mph (95 km/h) wind gusts
Corrosive Atmosphere	As encountered in coastal regions and/or heavily industrialized areas
Transport	Munson road tested, rail impact

1 Three-piece reflector option reduces width to 87 in.

2 Angular values for Ka-band are 1° to 30°, 30° to 130° and 130° to 180°.

3 Ku-band is Intelsat Type Approved with the following note on Noise Temperature: 73.7 K, 10° elevation, 11 GHz.

4 X-band feed includes high isolation filter.

5 Tie downs required.



Electrical	C-Band 2-Port		C-Band 2-Port		X-Band 2-Port		Ku-Band 2-Port		Ku-Band 4-Port		Ka-Band 2-Port	
	Linear Polarized	Circular Polarized	Linear Polarized	Circular Polarized	Linear Polarized	Circular Polarized	Linear Polarized	Circular Polarized	Linear Polarized	Circular Polarized	Linear Polarized	Circular Polarized
Frequency (GHz)	Receive	Transmit	Receive	Transmit	Receive	Transmit	Receive	Transmit	Receive	Transmit	Receive	Transmit
	3.625 - 4.200	5.850 - 6.425	3.625 - 4.200	5.850 - 6.425	7.250 - 7.750	7.900 - 8.400	10.950 - 12.750	13.750 - 14.500	10.950 - 12.750	13.750 - 14.500	20.200 - 21.200	30.000 - 31.000
Antenna Gain at Midband, dBi	38.20	42.00	38.06	42.10	43.50	43.60	47.19	49.00	47.10	48.80	52.30	55.20
Antenna Noise Temperature												
5° Elevation	49 K		51 K		68 K		63 K		85 K		143 K	
10° Elevation	38 K		50 K		59 K		60 K ²		75 K		123 K	
20° Elevation	33 K		49 K		55 K		56 K		69 K		109 K	
40° Elevation	34 K		48 K		55 K		55 K		68 K		101 K	
Typical G/T at 4.0 & 7.5 GHz												
20° Elevation, Clear Horizon	19.5 dB/K				23.1 dB/K							
C-Band 35° K LNA												
X-Band 55° K LNA												
Typical G/T at 4.0 & 10.95 GHz												
10° Elevation, Clear Horizon												
C-Band 35° K LNA			18.8 dB/K									
C-Band 50° K LNA			18.1 dB/K									
Ku-Band 70° K LNA							25.4 dB/K					
Ku-Band 90° K LNA							24.7 dB/K					
Typical G/T at 11.85 GHz												
20° Elevation, Clear Horizon									25.7 dB/K			
Ku-Band 70° K LNA									25.1 dB/K			
Ku-Band 90° K LNA												
Typical G/T at 20.70 GHz												
20° Elevation, Clear Horizon											28.7 dB/K	
Ka-Band 120° K LNA											27.4 dB/K	
Ka-Band 200° K LNA												
Pattern Beamwidth (in degrees at midband)												
-3 dB Beamwidth	2.12	1.37	2.09	1.35	1.11	1.03	0.72	0.60	0.71	0.60	0.40	0.29
-15 dB Beamwidth	4.45	2.88	4.39	2.84	2.33	2.16	1.51	1.26	1.49	1.26	0.84	0.61
Sidelobe Performance ²												
For Angle A from 2° to 30° (typical)												
	29-25 Log A		29-25 Log A		29-25 Log A		29-25 Log A		29-25 Log A		29-25 Log A	
For Angle A beyond mainbeam to 20°												
For Angle A from 30° to 130°							-10 dBi		-10 dBi		-10 dBi	
For Angle A from 130° to 180°							0 dBi		0 dBi		0 dBi	
Cross Polarization												
On Axis	30.0 dB	30.0 dB	19.7 dB	27.3 dB	21.3 dB	21.3 dB	35.0 dB	35.0 dB	35.0 dB	35.0 dB	24.8 dB	24.8 dB
Within 1.0 dB BW	28.0 dB	28.0 dB	19.7 dB	27.3 dB	21.3 dB	21.3 dB	27.0 dB	35.0 dB	27.0 dB	35.0 dB	24.8 dB	24.8 dB
VSWR	1.30:1	1.30:1	1.30:1	1.30:1	1.30:1	1.30:1	1.35:1	1.25:1	1.35:1	1.30:1	1.30:1	1.30:1
	(17.7 dB)	(17.7 dB)	(17.7 dB)	(17.7 dB)	(17.7 dB)	(17.7 dB)	(16.5 dB)	(19.0 dB)	(16.5 dB)	(17.7 dB)	(17.7 dB)	(17.7 dB)
Axial Ratio			1.81 dB	0.75 dB	1.50 dB	1.50 dB					1.00 dB	1.00 dB
Port-to-Port Isolation												
Rx/Tx (Rx frequency)	0 dB	-30 dB	0 dB	-50 dB	0 dB	-110 dB	0 dB	-30 dB	0 dB	-50 dB	0 dB	-50 dB
Tx/Rx (Tx frequency)	-60 dB	0 dB	-100 dB	0 dB	-110 dB	0 dB	-85 dB	0 dB	-85 dB	0 dB	-85 dB	0 dB
Feed Insertion Loss	0.15 dB	0.15 dB	0.40 dB	0.20 dB	0.45 dB	1.00 dB ⁴	0.30 dB	0.20 dB	0.60 dB	0.45 dB	0.30 dB	0.30 dB
Waveguide Interface Flange	CPR-229G	CPR-137G	CPR-229G	CPR-137G	CPR-112G	CPR-137G	WR-75 Flat	WR-75 Flat	WR-75 Flat	WR-75 Flat	WR-42 Flat	WR-28 Flat
Waveguide Interface Az Axis							WR-75 Flat		WR-75 Flat		WR-34 Flat	
Total Power Handling Capability	2 kW CW		2 kW CW		2 kW CW		1 kW CW		2 kW CW		250 W CW	
RF Specification	975-2837		975-2712		975-1012 ¹		975-1575 ³		975-1708		975-2901	