

C-Band Antenna-Mount SSPAs

PCD, PCM6SxxxLA

These high power solid-state amplifiers offer output powers of 50, 100, 125, 200 or 250 watts across the standard 5.850 to 6.425 GHz ("D") or extended 5.850 to 6.725 GHz ("M") satellite uplink bands. Housed in a compact weatherproof enclosure, the amplifiers can be mounted in an antenna hub or outdoors in applications where it is desirable to reduce cable losses by mounting the SSPA close to the antenna. The amplifiers feature a microprocessor-based M&C system that facilitates easy setup and control.

Options

- 1:1 and 1:2 redundant systems
- Integrated block upconverter with L-band input

Features

- 50/100/125/200/250 W saturated output power
- 75 dB gain
- Built-in monitor and control
- Temperature-compensated gain from -40 to +50 °C
- Serial interface (RS-232/-422/-485)
- Output isolator for high load VSWR protection
- 20 dB range digital gain adjustment
- RF output sample port (-40 dBc)
- Output power monitor
- Extremely light weight, nominally 36 lb (16 kg)
- Mounts on small antennas

SSPA Outline Drawing

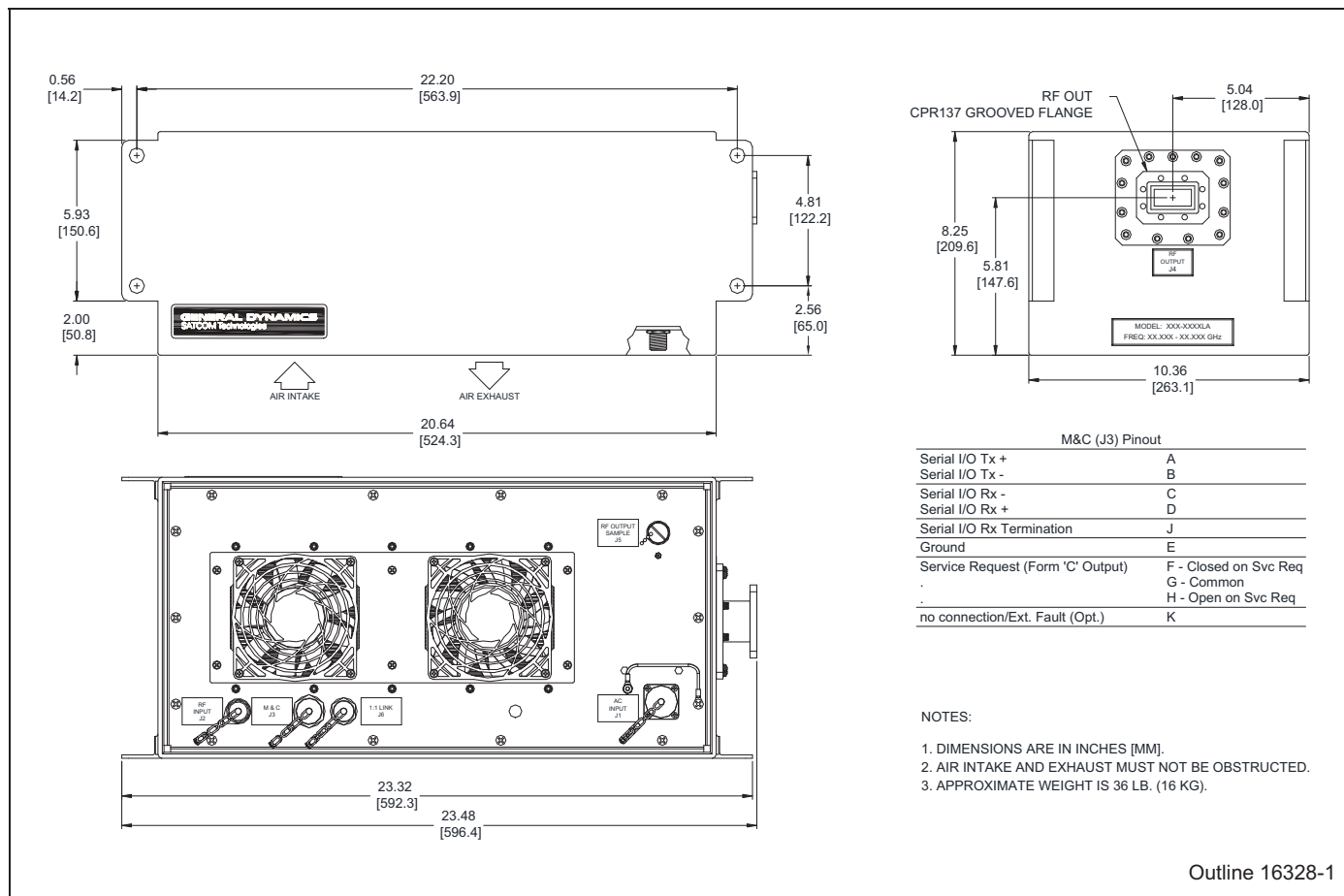

BUY NOW



Digisat International Inc.
4195 W. New Haven Ave., Suite 15
Melbourne, FL 32904
USA
+1-321-676-5250
Email: sales@digisat.org
http://www.digisat.org

Single-Thread SSPA Specifications

Parameter	Notes	Min.	Nom./Typ. [†]	Max.	Units
Frequency Range	Band 'D'	5.850		6.425	GHz
	Band 'M'	5.850		6.725	GHz
Input Frequency Range with Option 7, Block Upconverter	Band "D"	950		1525	MHz
	Band "M"	950		1825	MHz
Gain, at maximum gain setting		75			dB
Gain Adjust Range		20			dB
Gain Flatness	Full band, standard			±1.0	dB
	Full band, with Option 7			±1.5	dB
	Per 40 MHz, standard			±0.3	dB
	Per 40 MHz, with Option 7			±0.5	dB
Gain Stability vs. Temperature	-40 to +50 °C, standard		±1.0	±1.5	dB
	-40 to +50 °C, with Option 7		±2.0	±2.5	dB
Saturated Power Output (See Note 1)	50 W		+47 (50)		dBm (W)
	100 W		+50 (100)		dBm (W)
	125 W		+51 (125)		dBm (W)
	200 W		+53 (200)		dBm (W)
	250 W		+54 (250)		dBm (W)
Power Output, at 1 dB compression (P _{1 dB}) (See Note 1)	50 W	+46.5 (45)			dBm (W)
	100 W	+49.5 (89)			dBm (W)
	125 W	+50.5 (112)			dBm (W)
	200 W	+52.0 (158)			dBm (W)
	250 W	+53.0 (200)			dBm (W)
Two-tone Intermodulation	At 3 dB total backoff from 1 dB compression point		-30	-25	dBc
Group Delay	Linear			0.03	ns/MHz
	Parabolic			0.003	ns/MHz ²
	Ripple			1.0	ns p-p
AM/PM Conversion	At P _{1 dB}		2.5	3.5	°/dB
Noise Figure	At maximum gain, standard		8		dB
	At max. gain, with Option 7		20		dB
VSWR	Input		1.20	1.30	:1
	Input, with Option 7		1.35	1.50	:1
	Output		1.20	1.30	:1
Output Sample Port Connectors	Input		-40		dBc
	Output		Type N Female		
	Sample Port		CPR137G Waveguide		
	I/O		Type N Female		
	Power		10-pin MS, mate supplied		
			3-pin MS, mate supplied		
Power Requirements	Voltage		90-135 or 180-265		Vac
	Frequency	47		63	Hz
	Power, 50 W		450	500	W
	Power, 100 W		650	900	W
	Power, 125 W		750	1000	W
	Power, 200 W		950	1400 ^A	W
	Power, 250 W		1000	1500 ^A	W
	Power factor corrected		0.97		
Cooling System			Forced air		
Operating Temperature Range	Ambient air temperature	-40		+50	°C
Weight			36 (16)		lb (kg)
Dimensions	See outline drawing		8.25 x 23.48 x 10.36		inches
			210 x 596 x 263		mm

[†] When there is only one value on a line, the Nom./Typ. column is a nominal value; otherwise it is a typical value. Typical values are intended to illustrate typical performance, but are not guaranteed.

^A Cold start, at -40 °C and P_{OUT} in saturation.

Typical 1:1 Redundant System Outline Drawing

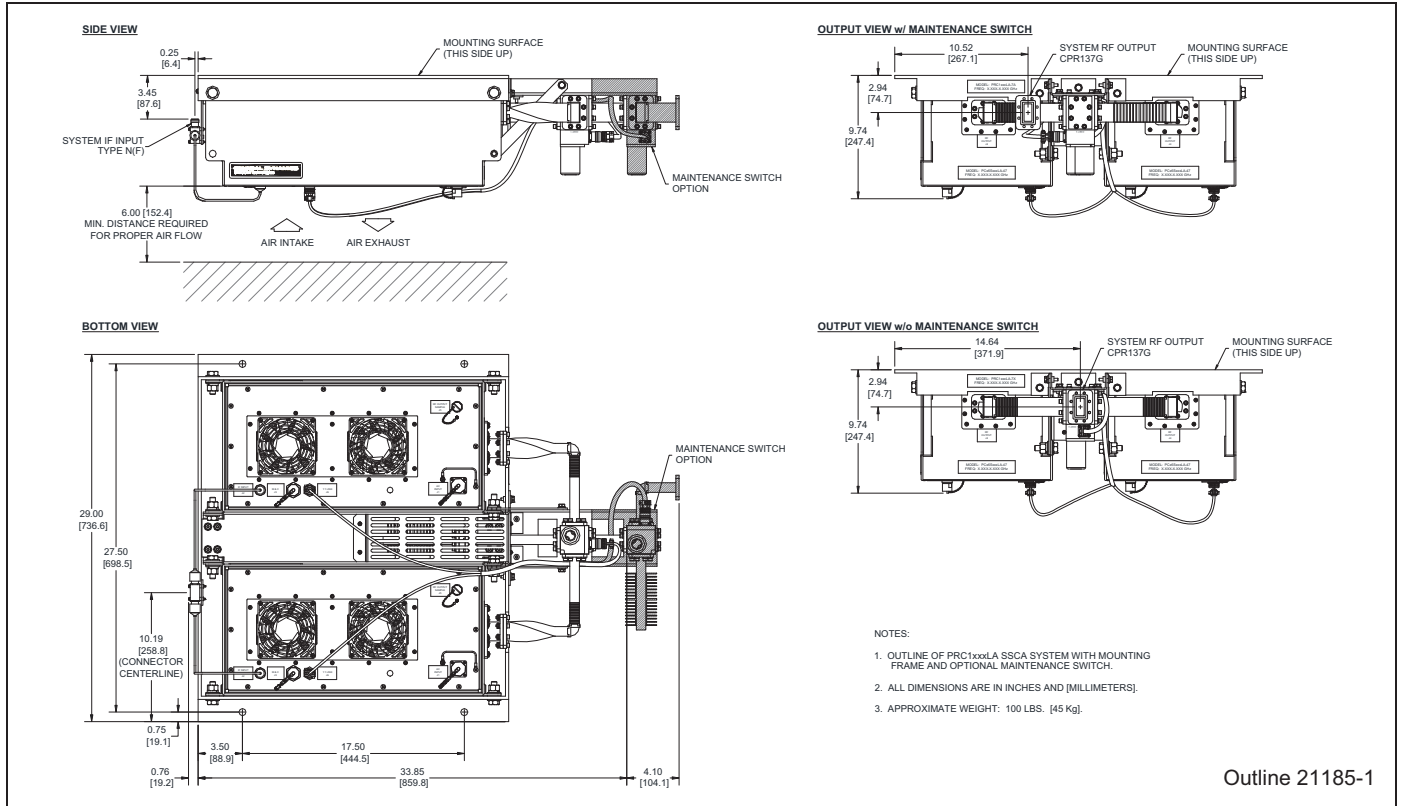

Part Number/Ordering Information

SSPA:

Part/Model No. **PC** **6S** **LA-XX**

5.850–6.425 GHz = D
 5.850–6.725 GHz = M

50 Watts = 050
 100 Watts = 100
 125 Watts = 125
 200 Watts = 200
 250 Watts = 250 ⁽¹⁾

Option:

1:1 Redundancy 4
 Redundant Capability
 (required for units in 1:1 systems)

Block Upconverter 7
 L-Band IF Input

⁽¹⁾ Consult factory for 250 W extended band.

⁽²⁾ Performance specifications of a redundant system depend on the installed configuration and optional accessories. Contact the factory for more information and for 1:2 system capabilities.

1:1 Redundant Systems ⁽²⁾ (Consists of 1:1 switching assembly, two SSPAs, and interconnecting cables):

Part/Model No. **PRC1** **LA-XX**

5.850–6.425 GHz = D
 5.850–6.725 GHz = M

50 Watts = 050
 100 Watts = 100
 125 Watts = 125
 200 Watts = 200
 250 Watts = 250 ⁽¹⁾

Options:

Block Upconverter 7
 L-Band IF Input

Maintenance Switch A
 Selects antenna or dummy load at system output

Related Accessory:

RCP-2001, SSPA Remote Control Panel

1U-high rack-mount panel enables remote manual control of the SSPA. Can be located up to 1.3 km (4000 ft.) away and interconnects with inexpensive cable. (One panel is required for each SSPA in a redundant system, for full remote manual control.)



Other Products

- Low Noise Amplifiers and LNA Systems
- Solid-State Power Amplifiers and SSPA Systems
- General Purpose Converters
- Satellite Communications Equipment
- Custom Subsystems

GENERAL DYNAMICS
SATCOM Technologies

© General Dynamics. All rights reserved. General Dynamics reserves the right to make changes to its products and specifications at any time and without notice. All trademarks indicated as such herein are trademarks of General Dynamics. All other product and service names are the property of their respective owners.