

C-Band Redundant LNA Systems

LRC-1000 Series

Introduction

Redundant LNA systems minimize system downtime due to LNA failure by providing a spare LNA and an automatic means of switching to the spare upon failure of a primary LNA. A 1:1 system provides one spare LNA for one primary LNA. A 1:2 system provides one spare LNA for either of two primary LNAs. The systems consist of an outdoor plate assembly which mounts at the antenna hub and an indoor control panel.

Plate Assembly Features

- LC-4000 Series Low Noise Amplifiers (LNAs)
- High quality dual waveguide/coaxial switches
- Manual override
- Waveguide input flanges
- Output coaxial isolators standard
- Tx reject filter(s), coupler(s), and offline I/O options available

Control Panel Features

- Standard 19" rack panel, 3½" high
- Dual, redundant power supplies
- Worldwide universal AC input capability
- Manual or automatic operation
- Monitors LNA bias currents to detect faults
- Automatically switches to standby LNA when fault occurs
- RS-232/-422/-485 and parallel I/O M&C interfaces
- Audible alarm

System Block Diagrams

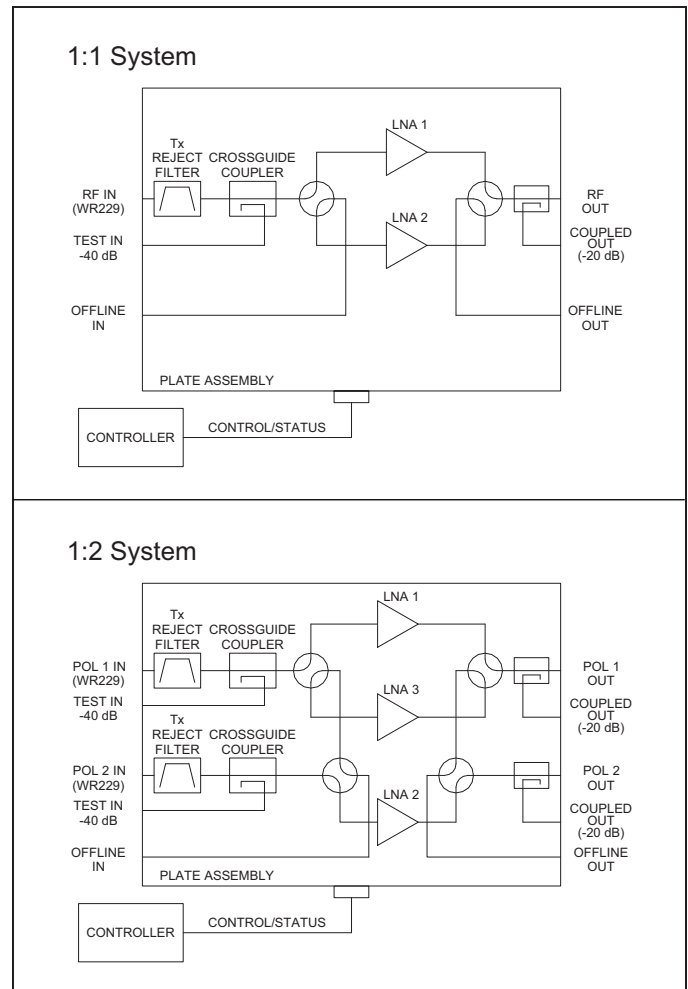

BUY NOW



Digisat International Inc.
4195 W. New Haven Ave., Suite 15
Melbourne, FL 32904
USA
+1-321-676-5250
Email: sales@digisat.org
<http://www.digisat.org>

System Specifications*

Parameter	Notes	Min.	Nom./Typ.†	Max.	Units
Frequency Range	Band "C"	3.6		4.2	GHz
	Band "D"	3.4		4.2	GHz
Noise Temperature, System	At +23 °C Versus temperature		See Table 1 See Table 2		
Gain	Standard LNA	60	63		dB
Gain Match	Between LNAs			1	dB
Gain Flatness	Full band Per 40 MHz			±0.5	dB
				±0.2	dB
Gain Stability	Per day, constant temp Versus temperature		-0.05	±0.2	dB dB/°C
VSWR	Input, standard		1.20	1.25	:1
	Input, with system option A or B, Tx filter		1.25	1.30	:1
	Output		1.20	1.25	:1
Power Output at 1 dB Compression (P _{1 dB})	Standard LNA	+10	+13		dBm
	LNA with Option 2	+18	+20		dBm
	LNA with Option 2 & system option D, output couplers	+17	+19		dBm
Third Order Output Intercept Point (OIP ₃)	Standard LNA	+20	+23		dBm
	LNA with Option 2	+28	+30		dBm
	LNA with Option 2 & system option D, output couplers	+27	+29		dBm
AM/PM Conversion	At -5 dBm out			0.05	%/dB
Group Delay per 40 MHz	Linear			0.02	ns/MHz
	Parabolic			0.002	ns/MHz ²
	Ripple			0.2	ns p-p
Maximum Input Power	Without damage			0	dBm
Desensitization Threshold for 5.850-6.425 GHz in (Band "C") 5.850-6.725 GHz in (Band "D")	Standard system			-10	dBm
	With system option A or B, Tx filter			+45	dBm
Connectors	RF Input RF Output Offline In/Out, Coupler In/Out		CPR229G Waveguide Flange Type N Female Type N Female		
Temperature Range	Switch Plate Assy	-40		+60	°C

* System specifications depend on choice of LNA and various options. Specifications shown are for a typical system using LC-4000 series LNAs.

† When there is only one value on a line, the Nom./Typ. column is a nominal value; otherwise it is a typical value. Typical values are intended to illustrate typical performance, but are not guaranteed.

Part Number/Ordering Information

C-Band LNA Systems*	L	R	C											X
System Type:	1:1	1												
	1:2	2												
LNA Frequency:	3.6-4.2 GHz	C												
	3.4-4.2 GHz	D												
LNA Noise Temp.:	30 K	3	0											
	35 K	3	5											
	40 K	4	0											
	45 K	4	5											
LNA Options:	+10 dBm output (std.)									X				
	+20 dBm output									2				
System Options:	No filter													X
	Tx reject filter, -60 dB													
	• 5.850-6.725 GHz reject band													A
	• 5.850-6.425 GHz reject band													B
	No input coupler(s)													X
	Input CG coupler(s), -40 dB													C
	No output coupler (s)													X
	Output coaxial coupler(s), -20 dB													D
	No offline I/O													X
	Offline I/O, terminated, with isolator													E
Control Cable:	No cable													X
(Standard service)	100 ft. (30 m)													1
	150 ft. (45 m)													2
	200 ft. (60 m)													3
	250 ft. (75 m)													4

Examples:

1:1 system with 3.6-4.2 GHz, 40 K LNAs, no LNA options, no system options, and 100 ft. cable:

Order Number L R C 1 C 4 0 - X X X X X 1

1:1 system with 3.4-4.2 GHz, 35 K LNAs, no LNA options, Tx Reject filter, CG coupler, and 200 ft. cable:

Order Number L R C 1 D 3 5 - X X A C X X 3

1:2 system with 3.6-4.2 GHz, 45 K LNAs, no LNA options, input CG coupler, output coax coupler, Offline I/O, and 150 ft. cable:

Order Number L R C 2 C 4 5 - X X X C D E 2

1:2 system with 3.4-4.2 GHz, 30 K LNAs with high power output option, input and output couplers, and 150 ft. cable:

Order Number L R C 2 D 3 0 - X 2 X C D X 2

* Note: Consult factory for custom configurations.

Table 1 — Typical System Noise Temperature with Various Options (Add to T_{LNA})

System Configuration:	— 1:1 —		— 1:2 —		
			Pol. 1	Pol. 2	Standby
Standard Configuration (Add to T _{LNA})	1.5 K	1.5 K	1.5 K	3.0 K	4.5 K
With 40 dB Crossguide Coupler(s)	2.0 K	2.0 K	2.0 K	3.5 K	5.0 K
With Transmit Reject Filter(s), Band "C"	4.5 K	4.5 K	4.5 K	6.0 K	7.5 K
With Transmit Reject Filter(s), Band "D"	9.5 K	9.5 K	9.5 K	11.0 K	12.5 K
With Tx Filter(s) and Coupler(s), Band "C"	5.0 K	5.0 K	5.0 K	6.5 K	8.0 K
With Tx Filter(s) and Coupler(s), Band "D"	10.0 K	10.0 K	10.0 K	11.5 K	13.0 K

Table 2 — Noise Temperature vs. Ambient Temperature

Noise temperature vs. ambient temperature can be found from the equation,

$$NT_2/NT_1 = (T_2/T_1)^n$$

where:

- NT₂ = Noise Temperature at T₂
- NT₁ = Noise Temperature at T₁
- T₂ = Temperature 2 in K
- T₁ = Temperature 1 in K
- n = 1.5 for the LNAs or = 1.0 for passive losses

For the case where T₁ = 296 K (+23 °C), the ratio NT₂/NT₁ is shown in the table below for both LNAs (n = 1.5) and for passive losses (n = 1.0):

Ambient Temperature T ₂ (°C)	n = 1.5 NT ₂ /NT ₁	n = 1.0 NT ₂ /NT ₁
0	0.89	0.92
+23	1.00	1.00
+40	1.09	1.06
+50	1.14	1.09
+60	1.19	1.13

Example: For a 1:1 system with Tx filter, crossguide coupler and 30 K LNAs, T_{LNA} = 30 K at +23 °C and passive losses = 5 K at +23 °C; thus, T_{sys} = 35 K at +23 °C. What is T_{sys} at +50 °C?

From the table, NT₂/NT₁ at 50 °C = 1.14 for the LNAs and 1.09 for the passive losses:

$$NT_2 = 1.14 \times (30 \text{ K}) + 1.09 \times (5 \text{ K}) = 34.2 \text{ K} + 5.4 \text{ K} = 39.6 \text{ K at } +50 \text{ °C.}$$

Controller Front Panel (1:1 System):

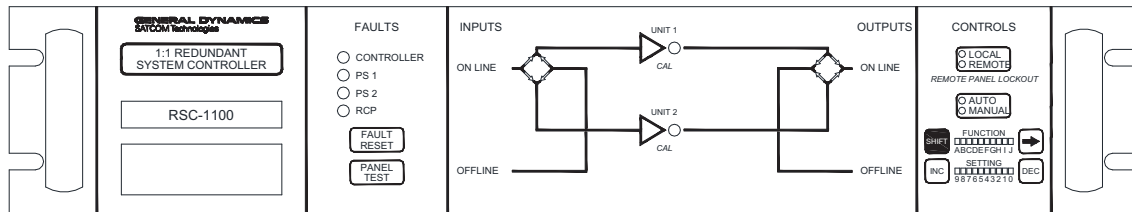

Controller Front Panel (1:2 System):

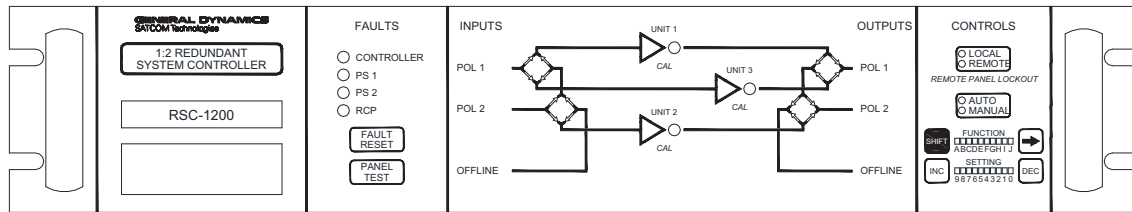

Controller Rear Panel (All models):

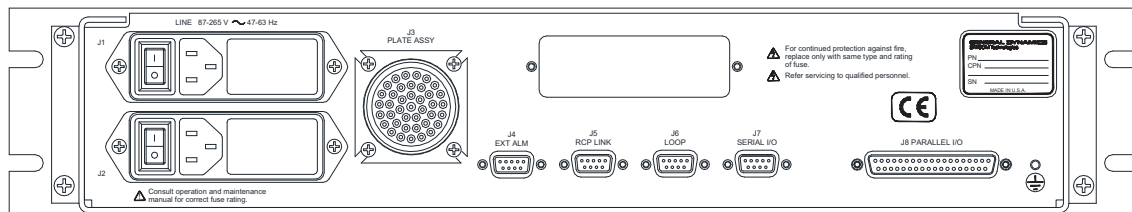

Specifications

Controller

LNA Status Monitor Method	Control panel monitors LNA bias current. Alarm is generated if current goes outside of allowed tolerance window.
Window Width	±5% to ±25% of nominal; software selectable in 5% steps
Switchover Time	100 ms
Serial I/O: Interface Connector	RS-232/RS-422/RS-485 2- or 4-wire 9-Pin D, female
Parallel I/O: Status outputs Control inputs Connector	Form 'C' dry contacts; 100 Vdc, 0.5 A, 3 W max (resistive load) Contact closures to ground; withstand 15 V, sink 20 mA 37-pin D, male
Controller Dimensions	19" (483 mm) W x 3.47" (88.1 mm) H x 17.5" (445 mm) D; 25 lb (11.4 kg)
Chassis Slides	Standard
Cable Length to Plate Assy	Order cable separately. 100 ft (30 m) to 500 ft (150 m) lengths in 50 ft (15 m) increments are standard; other lengths are available by special order.
AC Input	87-265 Vac, 47–63 Hz, 100 W. Dual AC inputs and dual redundant power supplies.
Operating Temperature Range	0 to +50 °C

Front Panel Controls and Indicators

LNA Status Alarms	LED Indicators glow green when OK, red when an LNA fault is detected.
PS1, PS2 Indicators	Glow red to show fault with dual redundant power supplies.
Panel Test Pushbutton	Lights all indicators & test audible alarm.
Unit Pushbuttons and Indicators	Pushbuttons are used to manually switch the LNAs. Arrow indicators show which LNAs are switched on-line. Unit indicators light red to show faulted LNAs. In 1:1 systems, LNA1 is normally the primary LNA and LNA2 is on standby. In 1:2 systems, LNA1 and LNA2 are the primary LNAs for Polarization 1 and Polarization 2, respectively. LNA3 is the standby LNA and can be selected for either polarization.
Auto/Manual Switch and Indicators	In Auto mode, an LNA failure initiates automatic switchover to the standby LNA. In manual mode, the on-line LNA can be selected from the front panel.
Remote/Local Switch and Indicators	Selects either local control, or remote control from serial I/O, parallel I/O, or remote panel.

Rear Panel I/O Interface

LINE 1 - J1, LINE 2 - J2	Dual power entry modules contain the AC line input connector, fuses, and power switch. System can be powered from separate AC lines if desired. Either or both power supplies are capable of operating the system.
TO PLATE ASSEMBLY - J3	Cable to antenna plate assembly carries LNA power and switch drive signals. Order cable separately. Standard lengths are from 100' (30 m) to 500' (150 m) in 50' (15 m) increments; other lengths are special order.
Parallel I/O - J8	Parallel I/O connection for customer control or monitoring. Capable of controlling all features of the system except remote/local switch. Form 'C' relay contact outputs (1:1 systems): <ul style="list-style-type: none"> • LNA1 status • PS1 status • Auto/Manual mode • LNA2 status • PS2 status • Local/Remote mode • Switch position Control inputs—contact closure to ground (1:1 systems): <ul style="list-style-type: none"> • LNA1 select • LNA2 select • Auto/Manual select Form 'C' relay contact outputs (1:2 systems): <ul style="list-style-type: none"> • LNA1 status • PS1 status • Auto/Manual mode • LNA2 status • PS2 status • Pol. 1: LNA1 or LNA3 • LNA3 status • Local/Remote mode • Pol. 2: LNA2 or LNA3 Control inputs—contact closure to ground (1:2 systems): <ul style="list-style-type: none"> • Pol. 1: LNA1 select • Pol. 2: LNA2 select • Auto/Manual select • Pol. 1: LNA3 select • Pol. 2: LNA3 select
Serial I/O and Loop - J6 & J7	RS-232/RS-422/RS-485 connectors for user M&C System. Commands provide monitoring, controlling, and configuration.
RCP Link - J5	For optional Remote Control panel, which duplicates all front panel functions.
External Alarm - J4	External Alarm inputs. Substitute for or combine with internal LNA current monitor alarms. Allows an external signal to indicate LNA failure. Unused inputs can be used as status inputs to M&C system.

1:1 Plate Assembly Outline Drawing, with Various Options Installed

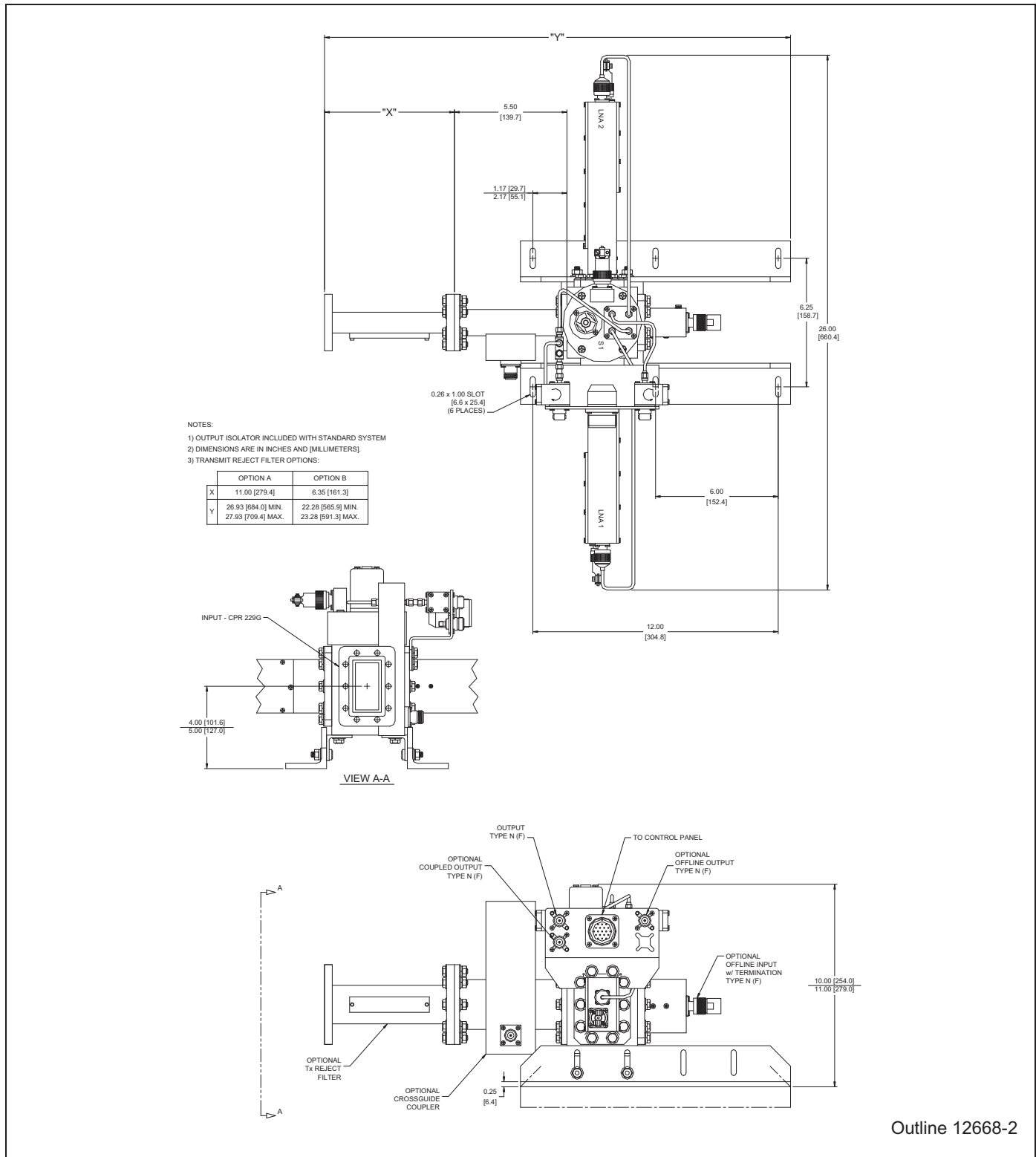

Outline 12668-2

1:2 Plate Assembly Outline Drawing, with Various Options Installed

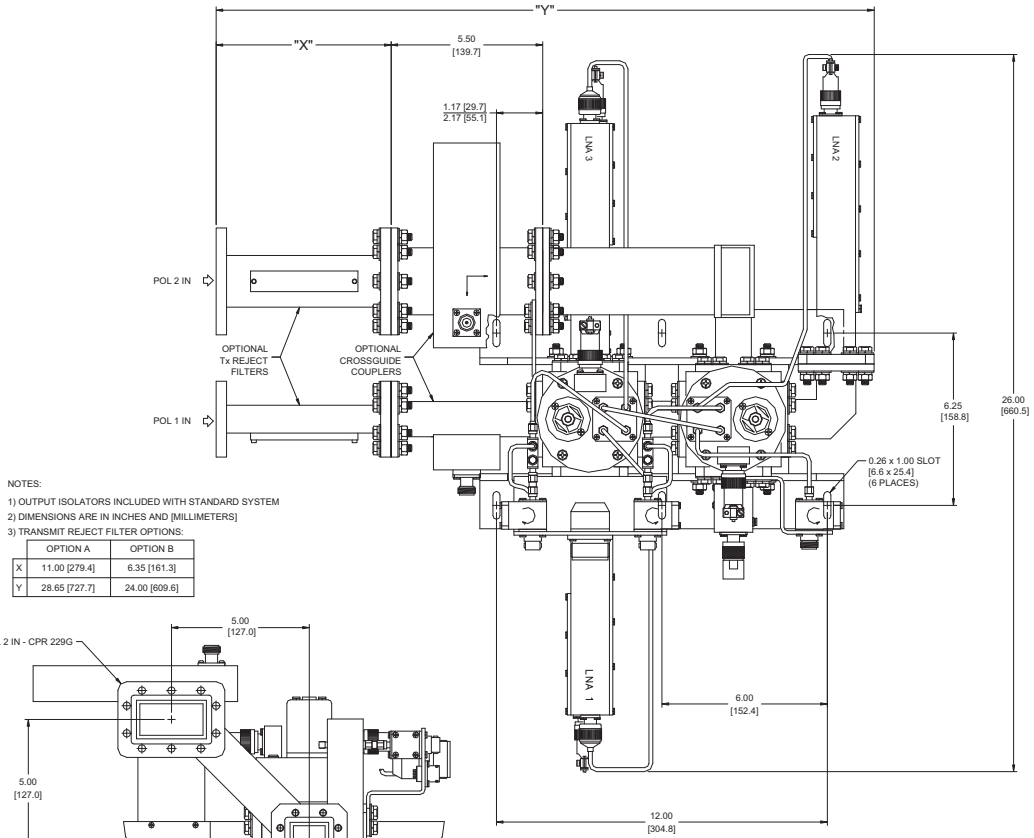

- NOTES:
 1) OUTPUT ISOLATORS INCLUDED WITH STANDARD SYSTEM
 2) DIMENSIONS ARE IN INCHES AND [MILLIMETERS]
 3) TRANSMIT REJECT FILTER OPTIONS:

	OPTION A	OPTION B
X	11.00 [279.4]	6.35 [161.3]
Y	28.65 [727.7]	24.00 [609.6]

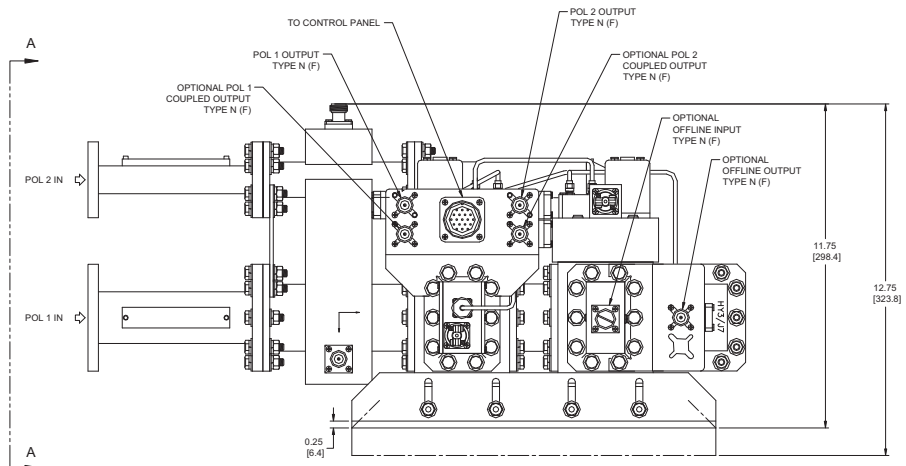
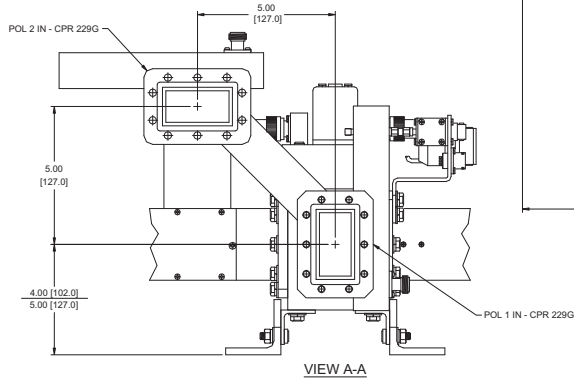



Other Products

- Low Noise Amplifiers and LNA Systems
- Solid-State Power Amplifiers and SSPA Systems
- General Purpose Converters
- Satellite Communications Equipment
- Custom Subsystems

GENERAL DYNAMICS
SATCOM Technologies

© General Dynamics. All rights reserved. General Dynamics reserves the right to make changes to its products and specifications at any time and without notice. All trademarks indicated as such herein are trademarks of General Dynamics. All other product and service names are the property of their respective owners.