

# Model C240M Mobile Antenna

## Mobile Antennas



*The Strength to Perform*

### Description

The General Dynamics SATCOM Technologies lightweight 2.4-meter mobile antenna is designed for worldwide transmit and receive operation in C, X, Ku and Ka-band. This mobile antenna consists of a carbon fiber composite reflector and back beam mounted on a cable-driven, elevation-over-azimuth positioning system. This results in an antenna with superior stiffness and high performance under wind loading conditions.

The unique shape and the accurate reflector surface provide exceptionally low sidelobe and cross-polarization performance well within INTELSAT and EUTELSAT requirements. The interchangeable feeds are palletized for quick, easy removal and replacement, allowing the end-user to effectively change frequency bands in the field within minutes.

### Features

- Aluminum/carbon fiber composite construction
  - Precision surface, high stiffness, robust design for vehicle mounting
- High performance
  - Low sidelobes, high EIRP capability, compliant under operational wind conditions
- Stow/deployment
  - Low profile, stow position on vehicle, precision alignment, automatic deploy and stow
- Multiband antenna system with rapid interchange between C, X, Ku and Ka-band feeds
- INTELSAT/EUTELSAT compliant for C/Ku-band

### Options

- Finishes (white or per customer spec)
- Integration (various TWT/amplifier mounting arrangements)
- Troposcatter capable

**Buy Now!**



**GENERAL DYNAMICS**  
SATCOM Technologies

## Technical Specifications

Mechanical	
Azimuth Travel	±150° continuous
Elevation Travel	0° to 90° of reflector boresight
Polarization Travel	±90°
Drive Rates	0.4°/second (azimuth) 0.7°/second (elevation) 2.6°/second (polarization)
Reflector	2.4-meter (94.5 in) carbon fiber composite (single or 3 segment)
Feed	Multiband interchangeable
Finish	White (standard; other optional finishes also available)
Weight	560 lbs (254 kg) without feed
Stow Height	24 in (61 cm)
Electrical Interface	25 ft (7.6 m) cable, pre-connectorized for various controller options
Integration	150 lbs (68 kg) feed boom mounted 300 lbs (136 kg) positioner mounted

Environmental	
Wind Loading <sup>1</sup>	
Operational	45 mph (72 km/h) gusting to 60 mph (97 km/h)
Survival	45 mph (72 km/h) gusting to 75 mph (121 km/h) any position 90 mph (145 km/h) stow position
Pointing Loss (operational winds)	2.0 dB peak (Ku-band Rx), performance dependent on controller capability
Temperature	
Operational	-22° to +122° F (-30° to +50° C)
Survival	-40° to +158° F (-40° to +70° C)
Rain	
Operational	4 in/h (10 cm/h)
Survival	6 in/h (15 cm/h)
Relative Humidity	0% to 100% with condensation
Solar Radiation	360 BTU/h/ft <sup>2</sup> (1000 Kcal/h/m <sup>2</sup> )
Radial Ice (survival)	1 in (25 mm) on all surfaces, 1/2 in (12 mm) on all surfaces with 80 mph (130 km/h) wind gusts <sup>1</sup>
Corrosive Atmosphere	As encountered in coastal regions and/or heavily industrialized areas

1 Depending on vehicle capabilities.

2 Vehicle capabilities directly affect antenna performance during and following transportation.

3 Angular values for Ka-band are 1° to 30°, 30° to 130° and 130° to 180°.

4 Ku-band is Intelsat compliant with the following note on Noise Temperature: 73.7 K, 10° elevation, 11 GHz.

5 X-band feed includes high isolation filter.



**Digisat International Inc.**  
4195 W. New Haven Ave., Suite 15  
Melbourne, FL 32904  
USA  
+1-321-676-5250  
Email: [sales@digisat.org](mailto:sales@digisat.org)  
<http://www.digisat.org>

# Model C240M Mobile Antenna

Electrical <sup>2</sup>	C-Band 2-Port Linear Polarized		C-Band 2-Port Circular Polarized		X-Band 2-Port Circular Polarized		Ku-Band 2-Port Linear Polarized		Ku-Band 4-Port Linear Polarized		Ka-Band 2-Port Circular Polarized	
	Receive	Transmit	Receive	Transmit	Receive	Transmit	Receive	Transmit	Receive	Transmit	Receive	Transmit
Frequency (GHz)	3.625 - 4.200	5.850 - 6.425	3.625 - 4.200	5.850 - 6.425	7.250 - 7.750	7.900 - 8.400	10.950 - 12.750	13.750 - 14.500	10.950 - 12.750	13.750 - 14.500	20.200 - 21.200	30.000 - 31.000
Antenna Gain at Midband, dBi	38.20	42.00	38.06	42.10	43.50	43.60	47.19	49.00	47.10	48.80	52.30	55.20
Antenna Noise Temperature												
5° Elevation	49 K		51 K		68 K		63 K		85 K		143 K	
10° Elevation	38 K		50 K		59 K		60 K <sup>4</sup>		75 K		123 K	
20° Elevation	33 K		49 K		55 K		56 K		69 K		109 K	
40° Elevation	34 K		48 K		55 K		55 K		68 K		101 K	
Typical G/T at 4.0 & 7.5 GHz 20° Elevation, Clear Horizon												
C-Band 35° K LNA	19.5 dB/K											
X-Band 55° K LNA					23.1 dB/K							
Typical G/T at 4.0 & 10.95 GHz 10° Elevation, Clear Horizon												
C-Band 35° K LNA			18.8 dB/K									
C-Band 50° K LNA			18.1 dB/K									
Ku-Band 70° K LNA							25.4 dB/K					
Ku-Band 90° K LNA							24.7 dB/K					
Typical G/T at 11.85 GHz 20° Elevation, Clear Horizon												
Ku-Band 70° K LNA									25.7 dB/K			
Ku-Band 90° K LNA									25.1 dB/K			
Typical G/T at 20.70 GHz 20° Elevation, Clear Horizon												
Ka-Band 120° K LNA											28.7 dB/K	
Ka-Band 200° K LNA											27.4 dB/K	
Pattern Beamwidth (in degrees at midband)												
-3 dB Beamwidth	2.12	1.37	2.09	1.35	1.11	1.03	0.72	0.60	0.71	0.60	0.40	0.29
-15 dB Beamwidth	4.45	2.88	4.39	2.84	2.33	2.16	1.51	1.26	1.49	1.26	0.84	0.61
Sidelobe Performance <sup>3</sup>												
For Angle A from 2° to 30° (typical)							29-25 Log A		29-25 Log A		29-25 Log A	
For Angle A beyond mainbeam to 20°	29-25 Log A		29-25 Log A		29-25 Log A							
For Angle A from 30° to 140°							-10 dBi		-10 dBi		-10 dBi	
For Angle A from 140° to 180°							0 dBi		0 dBi		0 dBi	
Cross Polarization												
On Axis	30.0 dB	30.0 dB	19.7 dB	27.3 dB	21.3 dB	21.3 dB	35.0 dB	35.0 dB	35.0 dB	35.0 dB	24.8 dB	24.8 dB
Within 1.0 dB BW	28.0 dB	28.0 dB	19.7 dB	27.3 dB	21.3 dB	21.3 dB	27.0 dB	35.0 dB	27.0 dB	35.0 dB	24.8 dB	24.8 dB
VSWR	1.30:1 (17.7 dB)	1.30:1 (17.7 dB)	1.30:1 (17.7 dB)	1.30:1 (17.7 dB)	1.30:1 (17.7 dB)	1.30:1 (17.7 dB)	1.35:1 (16.5 dB)	1.25:1 (19.0 dB)	1.35:1 (16.5 dB)	1.30:1 (17.7 dB)	1.30:1 (17.7 dB)	1.30:1 (17.7 dB)
Axial Ratio			1.81 dB	0.75 dB	1.50 dB	1.50 dB					1.00 dB	1.00 dB
Port-to-Port Isolation												
Rx/Tx (Rx frequency)	0 dB	-30 dB	0 dB	-50 dB	0 dB	-110 dB	0 dB	-30 dB	0 dB	-50 dB	0 dB	-50 dB
Tx/Rx (Tx frequency)	-60 dB	0 dB	-100 dB	0 dB	-110 dB	0 dB	-85 dB	0 dB	-85 dB	0 dB	-85 dB	0 dB
Feed Insertion Loss	0.15 dB	0.15 dB	0.40 dB	0.20 dB	0.45 dB	1.00 dB <sup>5</sup>	0.30 dB	0.20 dB	0.60 dB	0.45 dB	0.30 dB	0.30 dB
Waveguide Interface Flange	CPR- 229G	CPR- 137G	CPR- 229G	CPR-137G	CPR- 112G	CPR-137G	WR-75 Flat	WR-75 Flat	WR-75 Flat	WR-75 Flat	WR-42 Flat	WR-28 Flat
Waveguide Interface Az Axis			CPR- 137G	CPR-137G			WR-75 Flat		WR-75 Flat		WR-34 Flat	
Total Power Handling Capability	2 kW CW		2 kW CW		2 kW CW		1 kW CW		2 kW CW		250 W CW	
RF Specification	975-2837		975-2712		975-1012 <sup>5</sup>		975-1575 <sup>4</sup>		975-1708		975-2901	

# Model C240M Mobile Antenna

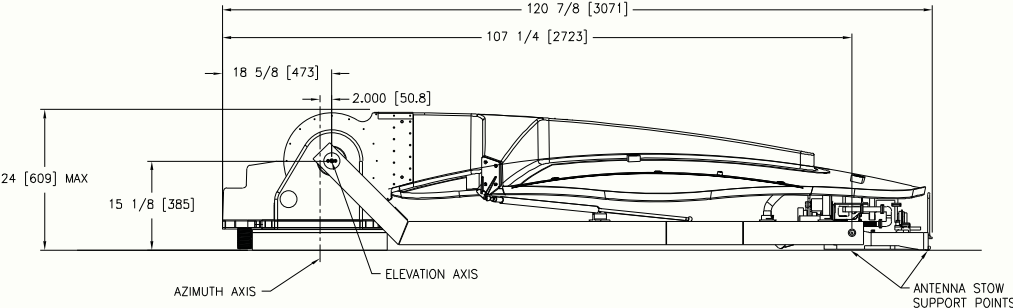
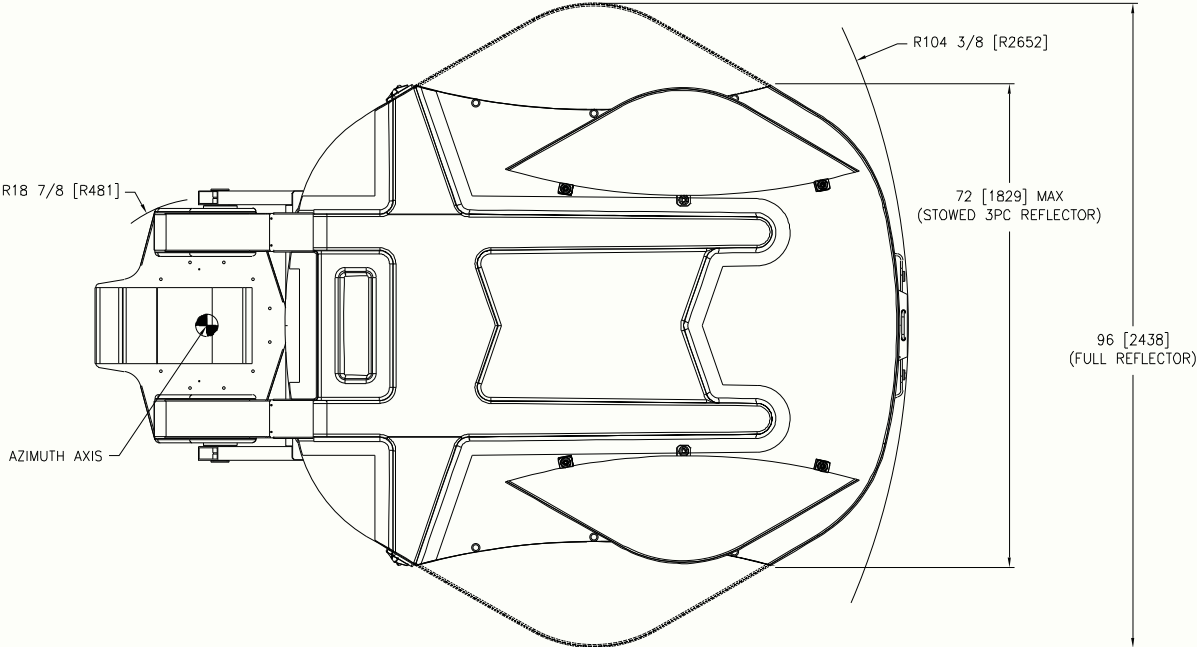

STOWED CONFIGURATION

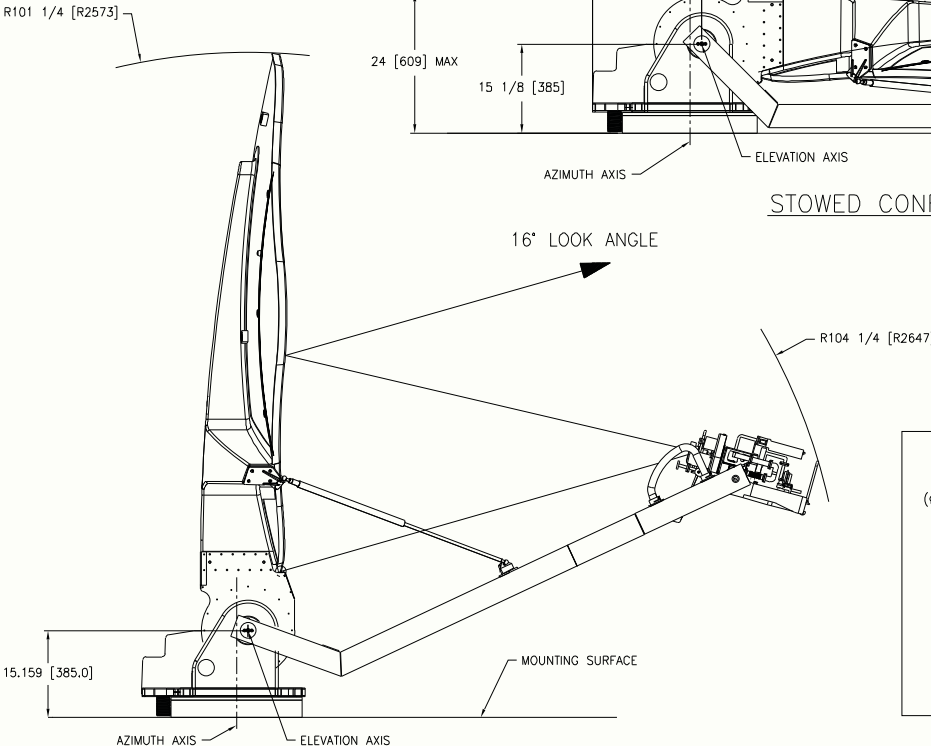

DEPLOYED CONFIGURATION

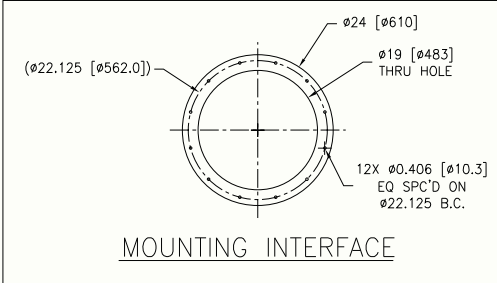

MOUNTING INTERFACE