

X-Band Solid-State Power Amplifiers

SPXB8xxxR

Using technology developed for ModuMAX™ amplifiers, these rack-mount SSPAs offer output powers of 100, 125, or 200 watts across the standard 7.90–8.40 GHz satellite uplink band. The SSPAs incorporate a modular architecture that includes the RF modules, power supplies, logic, fans, and front panel assembly. The amplifiers are designed for reliable service in fixed and mobile applications.

Features

- 100/125/200 W saturated output power
- Digital gain adjustment (20 dB range)
- Forward and reflected power monitoring
- Microprocessor-based monitor and control
- Serial interface (RS-232/-422/-485) standard
- 10 Base-T network interface (SNMP, HTTP)
- RF input and output sample port
- Integral 1:1 redundancy control

Applications

- Single-thread SSPA
- Redundant systems (1:1, 1:2)
- Fixed installations
- Mobile terminals
- Government and Military systems

Accessories

- RCP-2001 remote panel

Block Diagram

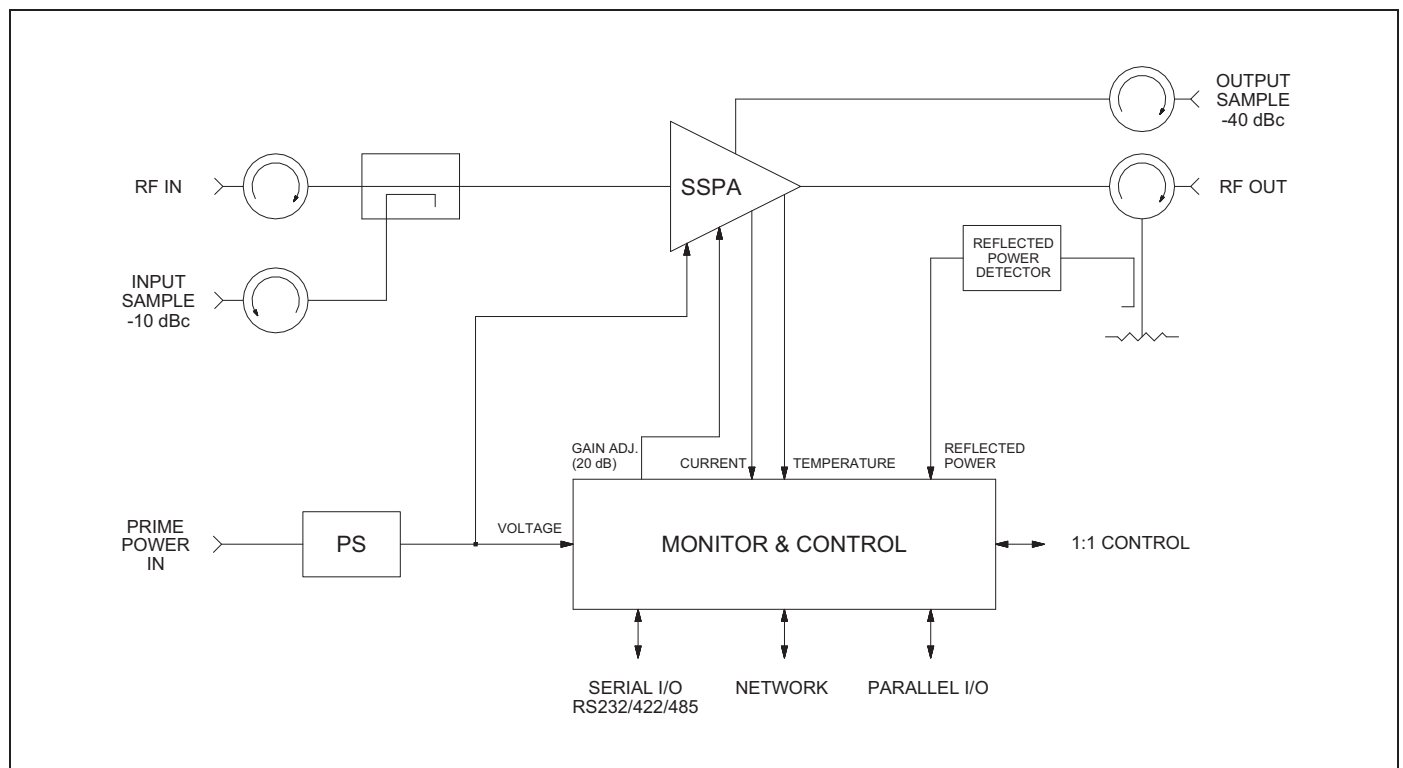

BUY NOW



Digisat International Inc.
 4195 W. New Haven Ave., Suite 15
 Melbourne, FL 32904
 USA
 +1-321-676-5250
 Email: sales@digisat.org
 http://www.digisat.org

Single-Thread SSPA Specifications

Parameter	Notes	Min	Nom/Typ [†]	Max	Units
Frequency Range		7.90		8.40	GHz
Gain, at maximum gain setting	Standard	70			dB
Gain Adjust Range	Digital, 0.1 dB steps	20			dB
Gain Flatness	Full band Per 40 MHz			±0.75	dB
				±0.3	dB
Saturated Power Output	100 W		+50 (100)		dBm (W)
	125 W		+51 (125)		dBm (W)
	200 W		+53 (200)		dBm (W)
Power Output at 1 dB compression (P _{1 dB})	100 W	+49.5 (89)			dBm (W)
	125 W	+50 (100)			dBm (W)
	200 W	+52 (159)			dBm (W)
Two-tone Intermodulation	At 3 dB total backoff from 1 dB compression point		-30	-25	dBc
Group Delay	Linear			0.03	ns/MHz
	Parabolic			0.003	ns/MHz ²
	Ripple			1.0	ns p-p
AM/PM Conversion	At P _{1 dB}		2.5	3.5	°/dB
Noise Figure	At maximum gain		8		dB
VSWR	Input		1.25	1.30	:1
	Output		1.20	1.30	:1
Front Panel Sample Ports	Input		-10		dB
	Output		-40		dB
Connectors	RF Input		Type N Female		
	RF Output		CPR112G Waveguide		
	Sample Ports		Type N Female		
	Serial I/O		9-pos D-sub Female, mate supplied		
	Parallel I/O		25-pos D-sub Male, mate supplied		
	System		15-pos D-sub, Male		
	RCP Link		9-pos D-sub, Male		
	Network		RJ-45 Jack		
Power		4-pos CE05, mate supplied			
Power Requirements	Voltage		90–135 or 180–270		Vac
	Frequency	47		63	Hz
	Power, 100 W		650	850 ^A	W
	Power, 125 W		850	1000 ^A	W
	Power, 200 W		1000	1200 ^A	W
	Power factor corrected		0.99		
Cooling System			Forced air. Intake on front panel.		
Operating Temperature Range	Ambient air temperature	0		+50	°C
Dimensions	See outline drawing		7 H x 19 W x 24 D		inches
			178 H x 483 W x 610 D		mm
Weight	Approximate		70 (32)		lb (kg)

[†] When there is only one value on a line, this column is a nominal value. Otherwise it is a typical value. Typical values are intended to illustrate typical performance, but are not guaranteed.

^A Cold start, at -40 °C and P_{OUT} in saturation.

Outline Drawings, SSPA (top) and Typical 1:1 Redundant System (bottom)

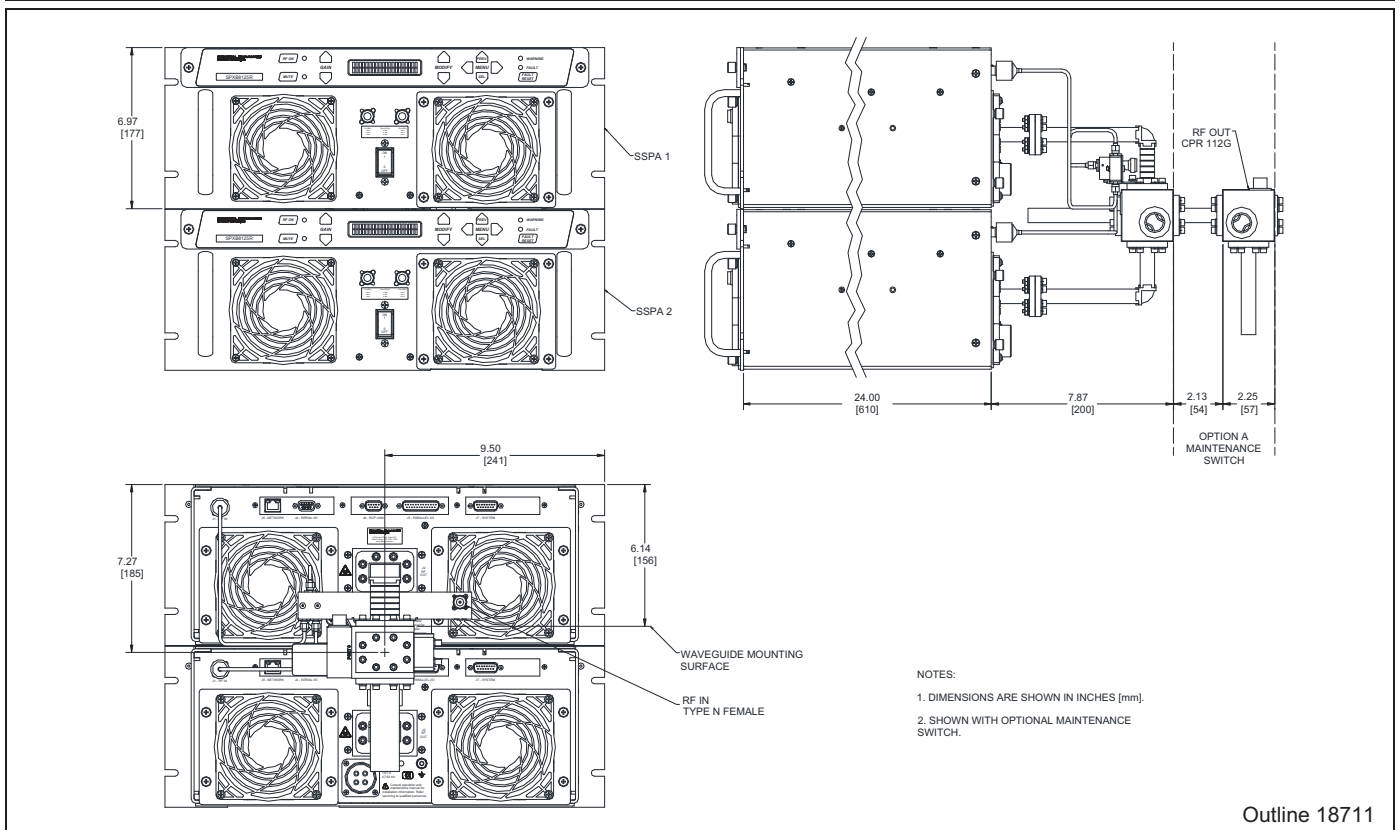
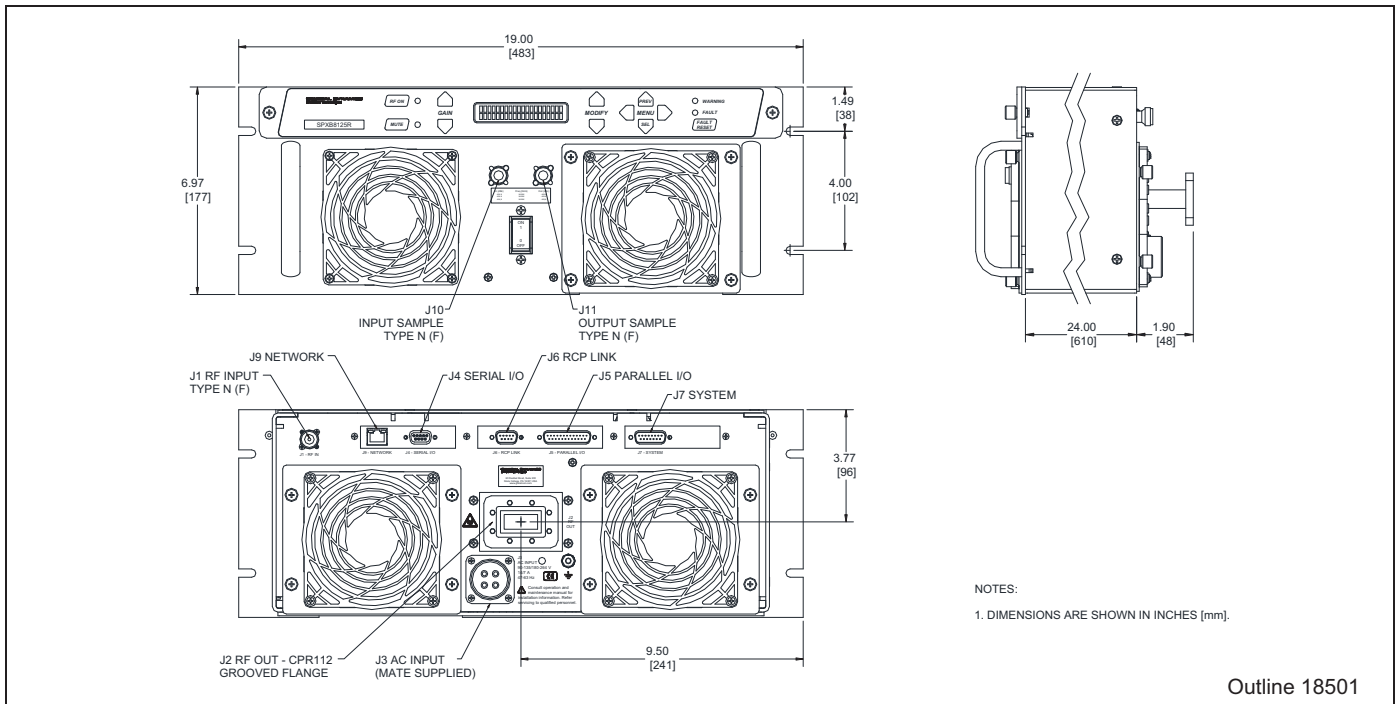

Connector Interface

Ref. Des.	Function	Connector Type	Mating Connector	Comment
J1	RF Input	Type N Female	Type N Male	
J2	RF Output	CPR112G Waveguide	CPR112 Flange	
J3	AC In	4-pos CE05, Male	4-pos MS or CE05, Female	Mate supplied
J4	Serial I/O	9-pos D-sub, Female	9-pos D-sub, Male	Mate supplied
J5	Parallel I/O	25-pos D-sub, Male	25-pos D-sub, Female	Mate supplied
J6	RCP Link	9-pos D-sub, Male	9-pos D-sub, Female	
J7	System	15-pos D-sub, Male	15-pos D-sub, Female	
J9	Network	RJ-45 Jack	RJ-45 Plug	
J10	Input Sample	Type N Female	Type N Male	Front panel mounted
J11	Output Sample	Type N Female	Type N Male	Front panel mounted

Part Number/Ordering Information

SSPA:

1:1 Redundant System*:

Part/Model No.	SPXB8 R	Part/Model No.	SPRX1B R-X
	<p>7.90–8.40 GHz = B</p> <p>100 Watts = 100 125 Watts = 125 200 Watts = 200</p>		<p>7.90–8.40 GHz = B</p> <p>100 Watts = 100 125 Watts = 125 200 Watts = 200</p>
Related Accessory:	<p>RCP-2001, SSPA Remote Control Panel</p> <p>1U-high rack-mount panel enables remote manual control of the SSPA. Can be located up to 1.3 km (4000 ft.) away and interconnects with inexpensive cable. (One panel is required for each SSPA in a redundant system, for full remote manual control.)</p>		

Option:

Maintenance Switch..... A
Selects antenna or dummy load at system output

* Performance specifications of a redundant system depend on the installed configuration and optional accessories. Contact the factory for more information and for 1:2 system capabilities.

Other Products

- Low Noise Amplifiers and LNA Systems
- Solid-State Power Amplifiers and SSPA Systems
- General Purpose Converters
- Satellite Communications Equipment
- Custom Subsystems

GENERAL DYNAMICS SATCOM Technologies