

Intellian[®]

v65

Installation and Operation User Guide

Serial number of the product

This serial number will be required for all troubleshooting or service inquiries.

Intellian[®]

© 2017 Intellian Technologies, Inc. All rights reserved. Intellian and the Intellian logo are trademarks of Intellian Technologies, Inc., registered in the U.S. and other countries. The v-Series and the v65 are trademarks of Intellian Technologies, Inc. Intellian may have patents, patent applications, trademarks, copyrights, or other intellectual property rights covering the subject matter in this document. Except as expressly provided in any written license agreement from Intellian, the furnishing of this document does not give you any license to these patents, trademarks, copyrights, or other intellectual property.

All other logos, trademarks, and registered trademarks are the property of their respective owners. Information in this document is subject to change without notice. Every effort has been made to ensure that the information in this manual is accurate. Intellian is not responsible for printing or clerical errors.

FCC Declaration of Conformity

Intellian Technologies, manufactures of stabilized maritime VSAT antenna systems for satellite communication at sea, supplies stabilized maritime VSAT antenna systems to the satellite communication service providers for their ESV (Earth Station on Vessels) networks.

FCC §25.222 defines the provisions for blanket licensing of ESV antennas operation in the Ku-band. It defines the antennas radiation, and each article regulates the followings;

§25.222 (a)(1)(i)(A): Regulation for Azimuth Direction & Co Polarization
§25.222 (a)(2)(i)(B): Regulation for Other Direction & Co Polarization
§25.222 (a)(1)(i)(C): Regulation for Cross Polarization

Intellian Technologies, Inc. declares that v65 complies with the threshold level as defined in §25.222(a)(1)(i)(A); and declares that v65 is in accordance with all defined regulations from §25.222(a)(1)(i)(B) to §25.222(a)(1)(i)(C) at the below stated input power spectral density, with an N value of 1.

Product description	Intellian v65, 65cm Ku-band maritime VSAT antenna system
EIRP spectral density limit	-22.4 dBW/ 4KHz

Intellian Technologies, Inc. declares that the above antenna will maintain a pointing error of less than or equal to 0.2 degree under specified ship motion conditions in accordance with the requirements of §25.222 (a)(1)(ii).

Intellian Technologies, Inc. declares that the above antennas will automatically cease the transmission with a mute command to the modem within 100 milliseconds if the target satellite and the axis of the main lobe of the ESV antenna exceeds 0.5 degree and will not resume until such angle is less than or equal to 0.2 degree in accordance with the requirements of §25.222 (a)(1)(iii)

Radiation pattern data is available upon request to verify the conformance.

Authority: **Steve Cha**
VP of Engineering/ R&D



Signature: _____



Date: May 20, 2016

Intellian Technologies, Inc.
US Headquarters
9004 Research Dr.
Irvine, CA 92618 USA
Tel: +1 949 727 4498

Intellian Technologies, Inc.
EMEA & APAC Headquarters
5F IDIS Tower, 344, Pangyo-ro (Sampyeong-dong),
Bundang-gu, Seongnam-si, Gyeonggi-do 13493 Korea
Tel: +82 2 511 2244

INDEX

INTRODUCTION	9
Intellian v65 Introduction	10
Intellian v65 Features	11
Basic System Configuration	12
Tools Required for Installation	14
INSTALLING THE ANTENNA	15
System Package	16
Planning the Installation	20
Antenna Installation	34
INSTALLING THE ACU	41
Mounting the ACU	42
Connecting Cables to the ACU	44
ACU Connector Guide	46
PC to ACU Communication Setup	48
Wi-Fi Connection	51
OPERATING THE ACU	55
Introduction	56
Normal Mode	58
Setup Mode	62
Installation Settings	63
Antenna Settings	67
Satellite Settings	79
System Settings	86
Aptus®	95
Introduction	96
Software Installation	97
PC to ACU Communication Setup	98
Toolbar Menus	101
System Property Status Dashboard	105
Work View Tabs	109
Aptus WEB	127
Introduction	128
Main Page	129
Antenna Settings	134
Firmware & Configuration	143
Administration	149
APPENDIX: Java Download and Install Guide	159
TECHNICAL SPECIFICATION	163
ENVIRONMENTAL SPECIFICATION	164
WARRANTY	165

INTRODUCTION

Intellian v65 Introduction

Intellian v65 Features

Basic System Configuration

Tools Required for Installation

Intellian v65 Introduction

The Intellian v65 is a fully integrated 65cm(25.6") Ku-band stabilized maritime VSAT system that is focused on higher RF performance over the existing 60cm class VSAT antenna.

The most competitive and highly efficient G/T performance combined with easy-to-install solutions for quick onboard deployment and maintenance ultimately enables you to realize a lower cost of ownership.

The v65 is built to meet or exceed the industry's most stringent standards such as FCC, ETSI, and R&TTE.

The antenna's 3-axis stabilized platform and advanced shock-resistant and vibration damping design of the pedestal is fully optimized to withstand the demanding maritime conditions and to ensure reliable broadband communications.

The unlimited azimuth range ensures continuous tracking without unwrapping the cables in the antenna and the low elevation angle (-20°) supports seamless signal reception at high latitudes.

It also acquires and locks onto the satellite without requiring a separate input from the ship's gyro-compass. This allows you to have a reliable, "always-on" broadband connection at sea.

The Intellian v65 is the smallest antenna that works without the need for a spread spectrum satellite network transmission.

This provides a compact system in a TDMA or SCPC transmission format. The higher-gain performance design enables the antenna to operate on the fringes of the signal footprint with superior operation.

It is suitable for high-speed internet, weather & chart updates, email, file and image transfer, video conference, VoIP, VPNs and database backup.

The Antenna Control Unit (ACU) supports Wi-Fi connectivity for a simple remote PC connection.

The v65 operates with just two cables to the antenna, combining TX signals and +48V DC BUC power in one cable and the RX signal in the second cable. The cables are connected directly to the radome base.

Intellian v65 Features

Superior RF Performance

The v65 provides a superior antenna performance and cross-pol isolation characteristics over existing 60cm class VSAT systems by incorporating highly efficient, in-house designed RF components.

Reliability Enhanced

The v65 is built upon the industry proven stabilization platform. The addition of a high performance reflector and feeder design along with an encoder integrated new motor driving mechanism ensures improved tracking accuracy and reliability of the system. These enhancements elevates the v65 to the top of the existing 60cm class.

Wide Elevation Angle

The v65's wide-look angle pedestal is designed for extremely low or high latitude areas, such as the Scandinavian Peninsula or the Equatorial regions.

Combined BUC Power and TX Signal

The v65 offers a single Tx cable solution that supplies 48V DC power and TX signal together from the antenna control unit via one RF cable.

Gyro-free Satellite Search Capability

Intellian's gyro-free satellite search function enables the v65 to acquire and lock onto the satellite without requiring a separate input from the ship's gyro-compass.

Quick and Easy Installation

The v65 is delivered without shipping brackets making it easy to deploy without the need to open the radome.

In addition, the RF cable connectors are outside the radome which reduces the time for cabling the ACU to the ADU.

Aptus Remote Management Solution

The v65 can be accessed, monitored, and controlled from any location in the world. Additionally, hundreds of routine maintenance activities can be automated.

These functions include operating firmware upgrades, tracking parameters resets, and system diagnosis including the event history logging feature. can be accessed, monitored, and controlled from any location in the world.

Wireless & Networking Connectivity

Wi-Fi connectivity with Intellian Aptus Mobile enables advanced system control and monitoring, including One-Touch satellite library and firmware updates from iOS or Android devices.

The Intellian LAN port on the ACU provides easy networking connectivity to other Intellian systems enabling integrated monitoring and control of all Intellian networked devices.

Basic System Configuration

For your satellite communication system to work properly, the system will have to be connected with all of the provided components properly, as shown in the figure below. Separate purchase of a satellite modem, ship's gyrocompass, and Intellian Dual VSAT Mediator may be required.

NOTE: BUC power should set to ON from the modem when you connect to a 4W BUC. BUC power should set to OFF from the modem when you connect to an 8W/16W BUC.

Basic System Configuration (8W/16W BUC)

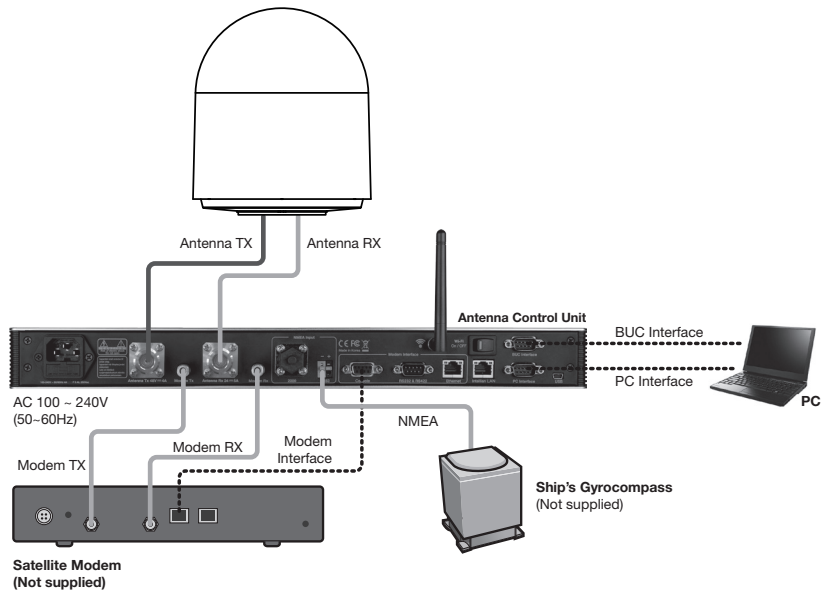

Basic System Configuration (4W BUC)

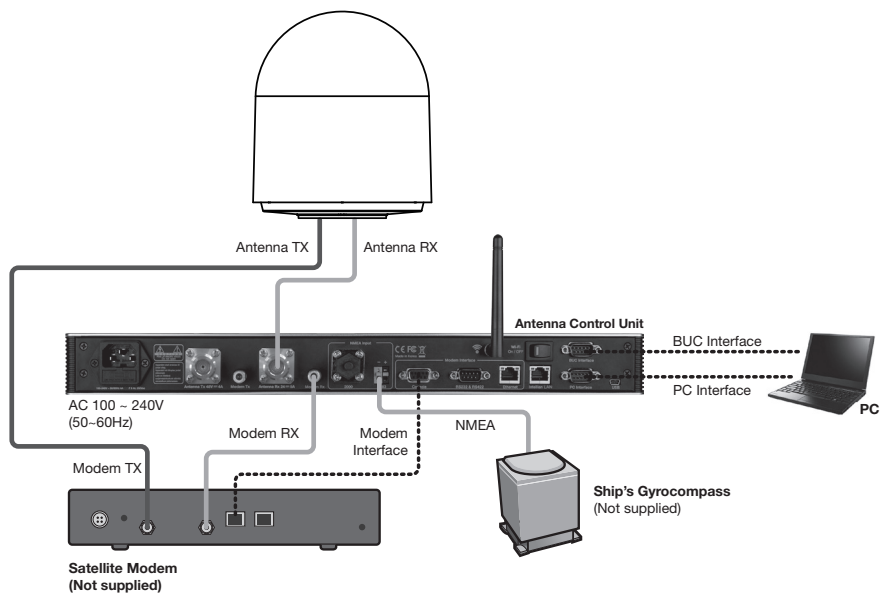

CAUTION: Please ensure that the Tx and Rx cables are correctly terminated in the power box inside the radome and on the ACU. Failure to connect these correctly will cause system damage. Do not switch cables.

Dual System Configuration

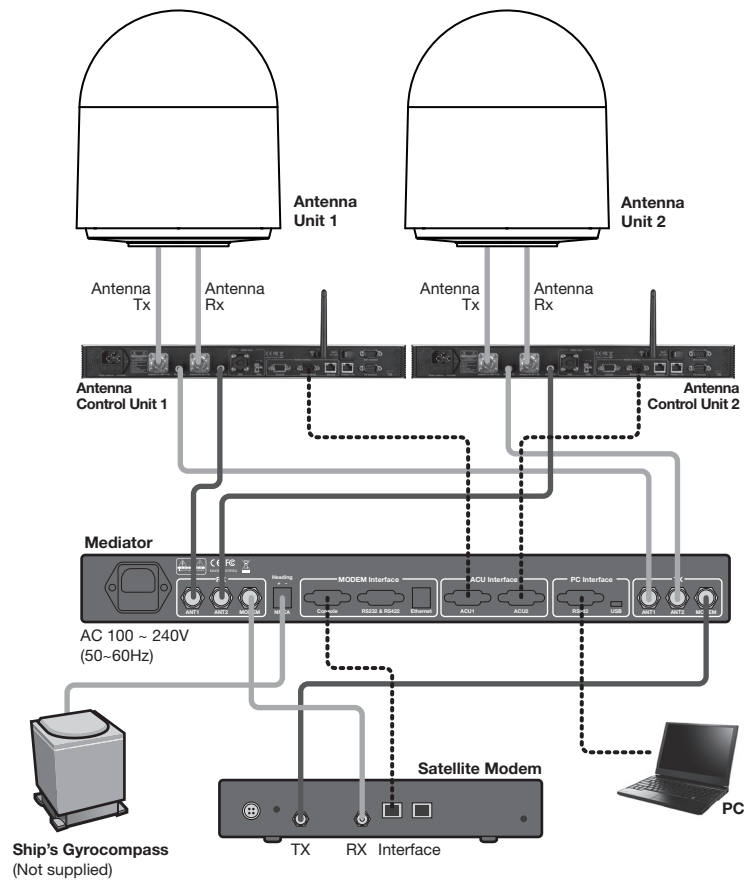

Tools Required for Installation

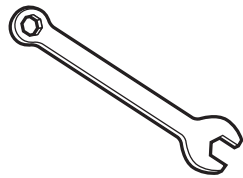

11mm Wrench

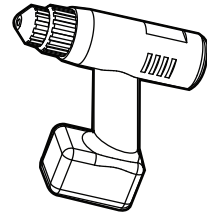

Power Drill

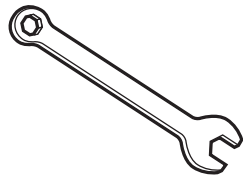

19mm Wrench

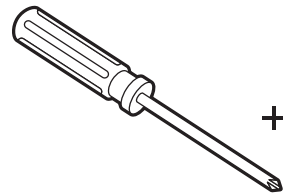

Phillips Head Screwdriver

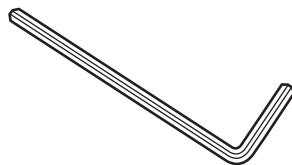

5mm Allen/Hex key

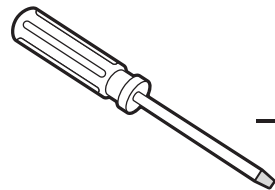

Flat Head Screwdriver

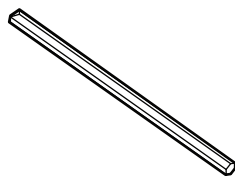

5mm Allen/Hex key
(for Power drill)

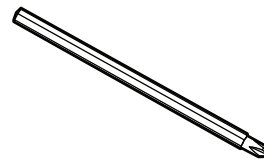

Head Screwdriver
(for Power drill)

INSTALLING THE ANTENNA

System Package

Antenna Unit

ACU (Antenna Control Unit)

Installation Kit

Planning the Installation

Selection of Antenna Installation Site

Minimize Satellite Blockage

Avoid RF Interference

RF Hazard Precautions

Antenna Dimensions

Antenna Mounting Templates

Position the Waterproof Foam

Mast design recommendation

Mast Making Guide

Position the Radome

Placing cables on the Mast

System Cables

RF Cable (Customer Supplied)

Antenna Installation

Unpacking the wooden crate

Placing the antenna on a mast

Mounting the Radome

Connecting RF Cables (Customer Supplied)

System Package

The package of the Intellian v65 consists of antenna unit, ACU and installation kit box.

Antenna Unit



ACU



Installation kit box

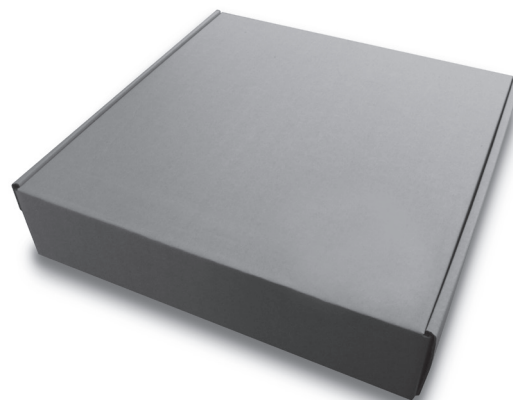

Antenna Unit

The antenna unit includes an antenna pedestal inside a radome assembly. The pedestal consists of a satellite antenna main dish with RF components mounted on a stabilized pedestal. The radome protects the antenna pedestal assembly from the severe marine environment.

Antenna Unit



ACU (Antenna Control Unit)

ACU provides power to the antenna and Block Up Converter (BUC). The digital Vacuum Fluorescent Display (VFD) allows for easy operation of the ACU, even in the dark.

Antenna Control Unit



Front panel



Rear panel



Installation Kit

Contains the items required for installing the antenna unit and ACU on the vessel.

ACU box			
Description	Q'ty	Size	Remarks
Antenna Control Unit (ACU)	1	431mm x 380mm x 44mm	Antenna Control Unit
User Manual	1		
Mounting Template	1		
RF Hazard Sticker	1		Radiation Safety Distance Label (15m)
Wifi Antenna	1	110mm	
USB Flash Drive	1		Antenna Software and User Manual file
Components box			
Description	Q'ty	Size	Remarks
ACU Bracket (Rack)	2		ACU-19inch Rack
ACU Bracket (Table)	2		ACU-Table
AC Power Cord (CEEE7/7)	1	1.5m	ACU Power
AC Power Cord (USA)	1	1.5m	ACU Power
PC Serial Cable	1	1.8m	ACU to PC
USB Cable (A-A)	1	1.8m	ACU to PC
Ethernet Cable (RJ45 / LAN)	1	1.5m	ACU to PC
RG6 Cable	2	3m	ACU to Receiver
iDirect Interface Cable	1	1.5m	ACU to Modem
D-sub 9 Pin Male Connector	2	-	ACU
N to F Adaptor	2		N(Male) to F(Female) Adaptor
Hex Bolt	5	M12 x 100L	
Flat Washer	5	M12	Antenna mounting 4 Sets Spare 1 Set
Spring Washer	5	M12	
Hex Nut	10	M12	
Hex Head Wrench Bolt	5	M6 x 40L	
Spring Washer and Flat Washer	5	M6	Radome (Spare Bolts)
Self-Tapping Screw	5	M4 x 16	Table Mount Bracket
Flat Head Screw	10	M4 x 12L	Rack Mount Bracket ACU
Sems Bolt	5	M3 x 12L	Table Mount Bracket ACU
Radome Door Key	2		1 Door key and 1 Spare key
Waterproof Foam	1	230mm x 285mm	On the Mounting Surface

Planning the Installation

Selection of Antenna Installation Site

The mounting platform should be robust enough and not subject to vibration. The movement of the antenna can be minimized by installing at the center of the vessel. If these conditions can be only partially satisfied, find the best compromised installation site.

Minimize Satellite Blockage

Install the antenna in accordance with the following procedures to ensure maximum performance of the antenna. The ideal antenna site should have a clear view of the horizon or satellite with all around clearance. Please be sure there are no obstacles within the EL range -20° to $+115^{\circ}$ from the center of the antenna. Obstacles can prevent the antenna from transmitting and receiving the satellite signal.

Elevation Limit
of Obstacles

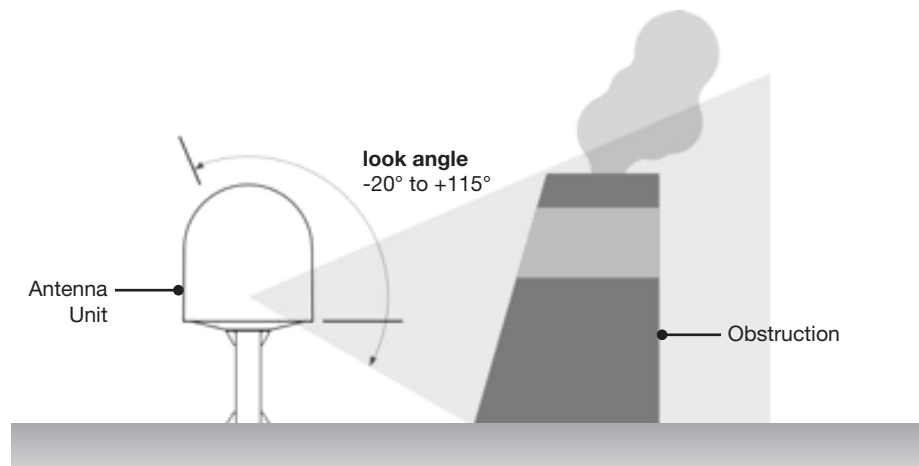

Avoid RF Interference

Do not install the antenna near the high power short wave radar.
 Most radar transmitters emit RF energy within an elevation range of -15° to $+15^{\circ}$.
 For this reason, It is recommended to position the antenna at least 15 feet (4.6 m)
 away from the radar.

Potential
 RF Interference

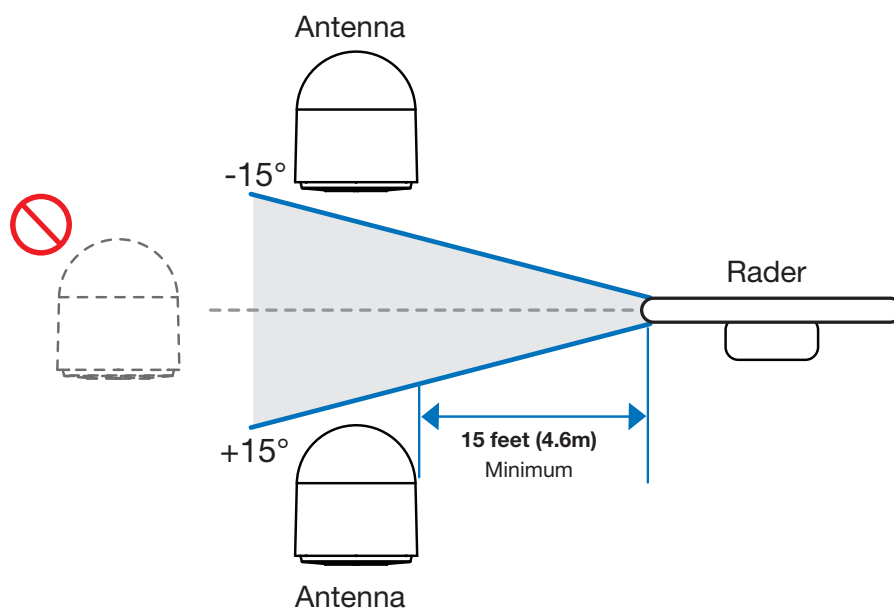

WARNING:
 Never place the antenna in the beam path of the radar regardless of distance. The high power short wave radar may impair its performance or damage the antenna.

RF Hazard Precautions

The antenna is designed to be used with radiation transmit equipment manufactured by others. Exposure to RF radiation, including exposure associated with an improper use of the transmit equipment, may be hazardous to persons close to the above deck unit. Ensure safety of personnel who work on the system.

During transmission, ensure to keep the minimum safety distance. The recommended minimum safety distance to the reflector on the focal line is about 15m, based on a radiation level of 5mW/ 2cm that applies under occupational/controlled environment. No hazard exists -20° below the antenna's mounting plane.

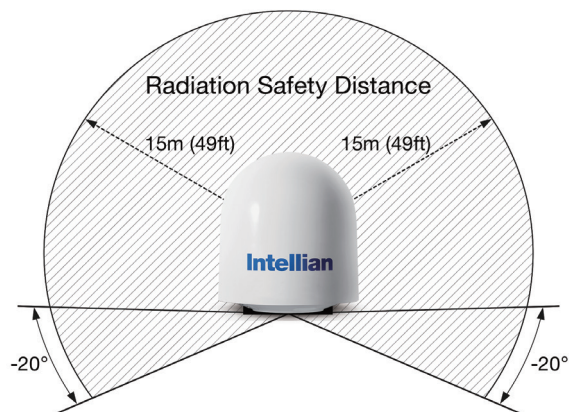

Antenna Dimensions

The method of installation and mounting of antenna may vary with vessel design but the following procedures are applicable in most situations, and will result in a secure and effective installation. Confirm the height and diameter of the antenna before installing it.

Radome Dimensions

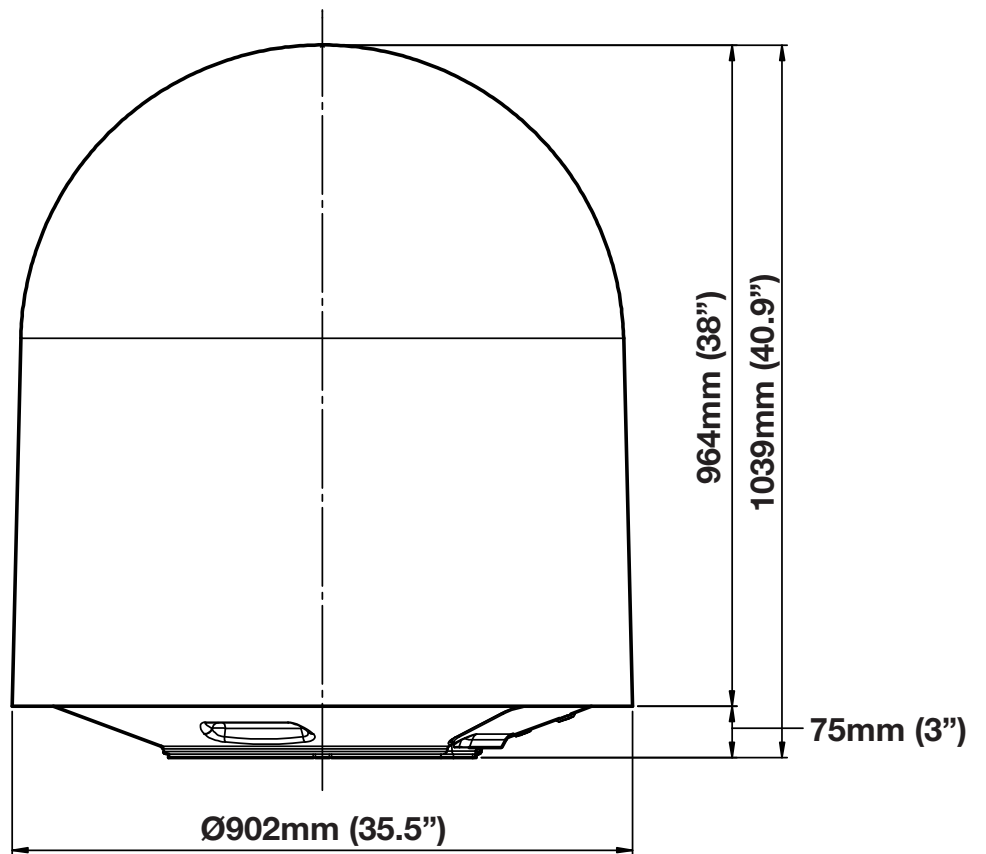

Antenna Mounting Templates

The mounting holes must be in the exact same place as shown in the diagram below.

Antenna Bow direction

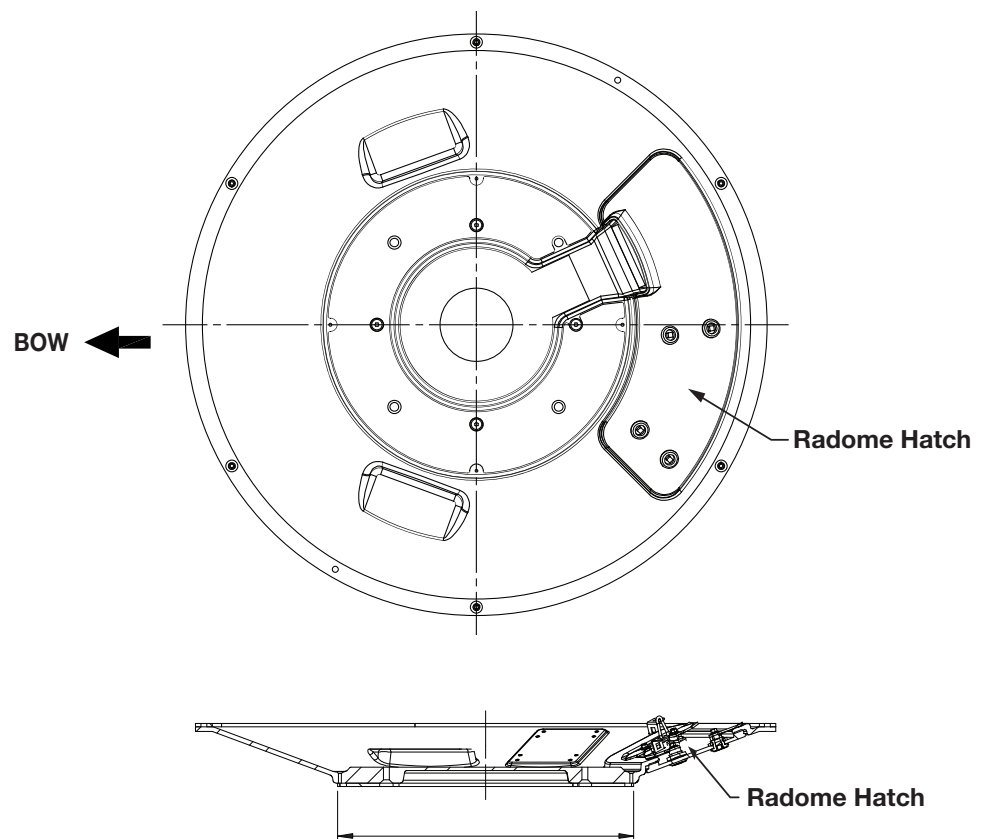

Antenna mounting hole pattern

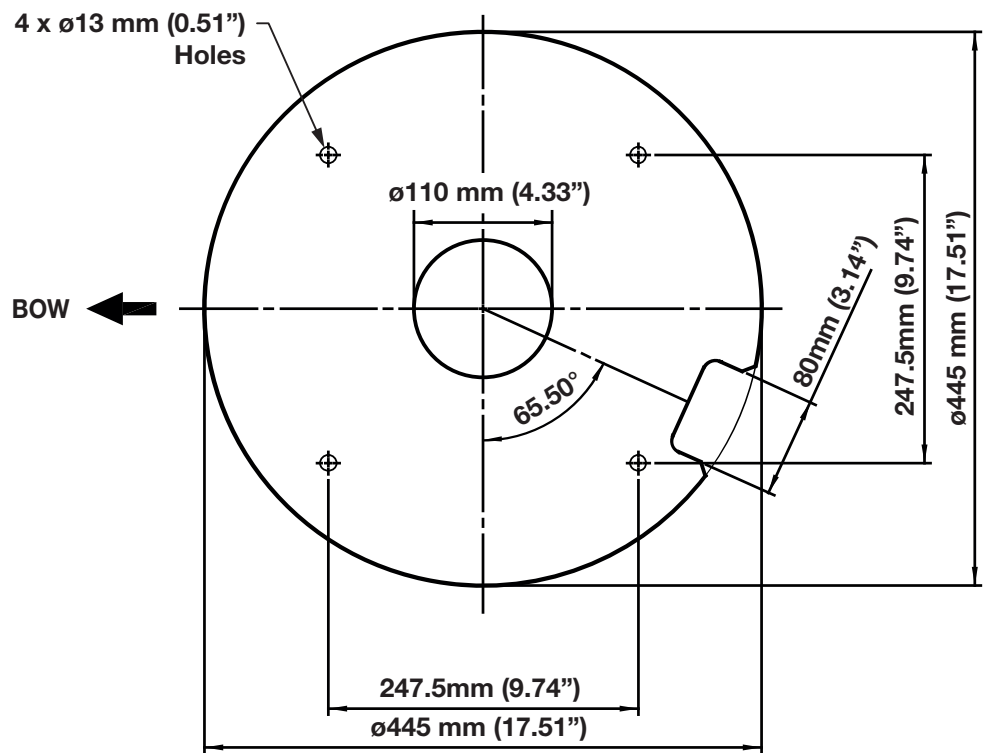

Position the Waterproof Foam

Peel off the paper backing from the supplied waterproof foam to expose the adhesive. Then press the waterproof foam down firmly onto the mounting surface, ensuring the hole in the waterproof foam aligns with the cable access hole in the mounting surface.

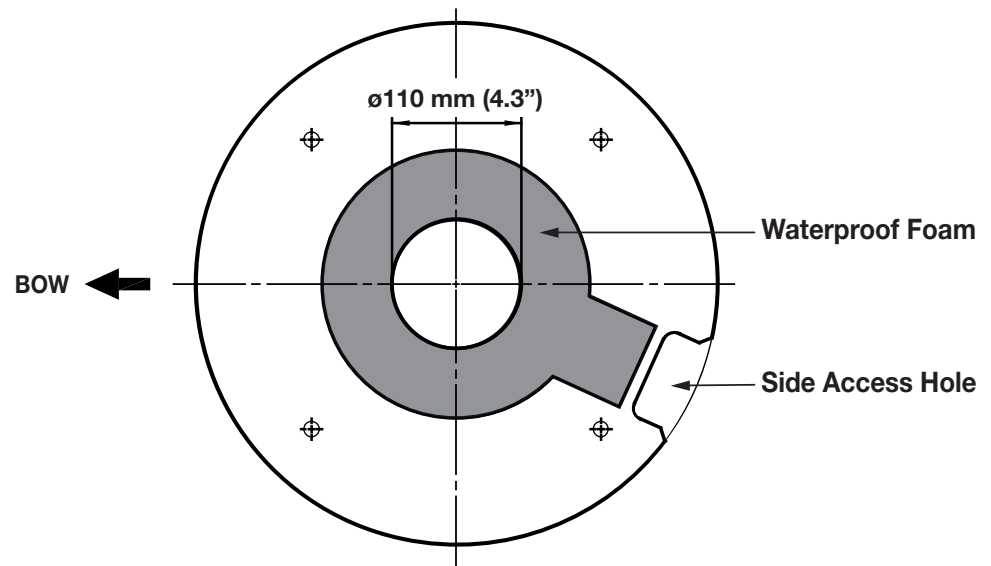

NOTE: When placing the waterproof foam on the mounting surface, be careful of the direction of the side access hole.

Mast design recommendation

Intellian strongly recommends installing the antenna less than 1200mm (47") above the deck. If the antenna has to be installed more than 1200mm (47") above the deck, be sure to install it in a safe place where there is enough space to set the radome aside in case of repair. But once again, the best place for the antenna would be less than 1200mm (47") above the deck.

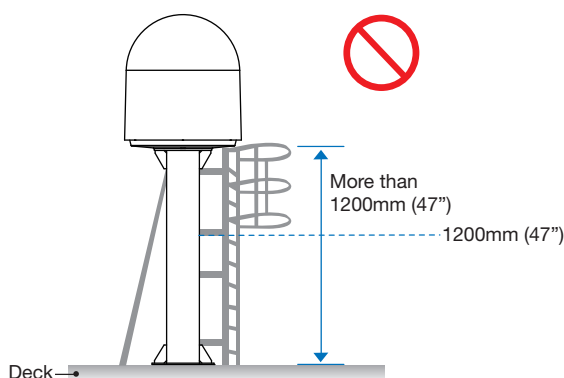
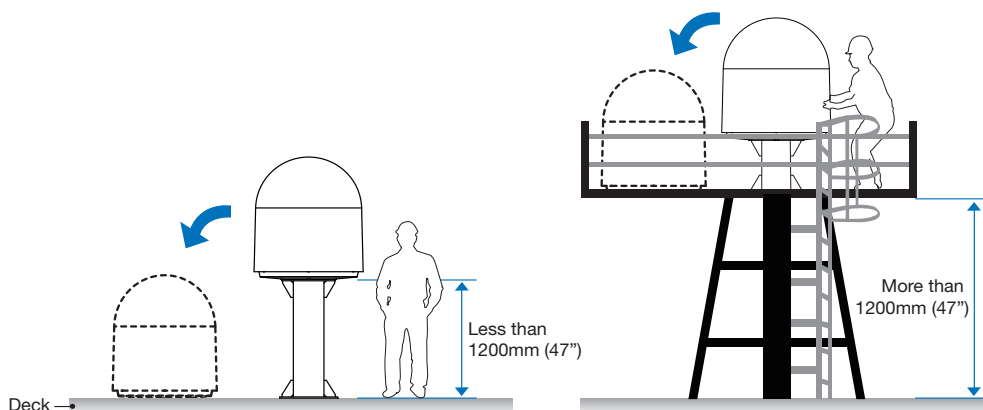

WARNING: Do not install unless you secure enough space to repair. Intellian strongly recommends installing the antenna less than 1200mm (47") above the deck.

Mast Making Guide

Confirm the height and diameter of the mast before installing it. The mounting holes must be in the exact same place as shown in the diagram below.

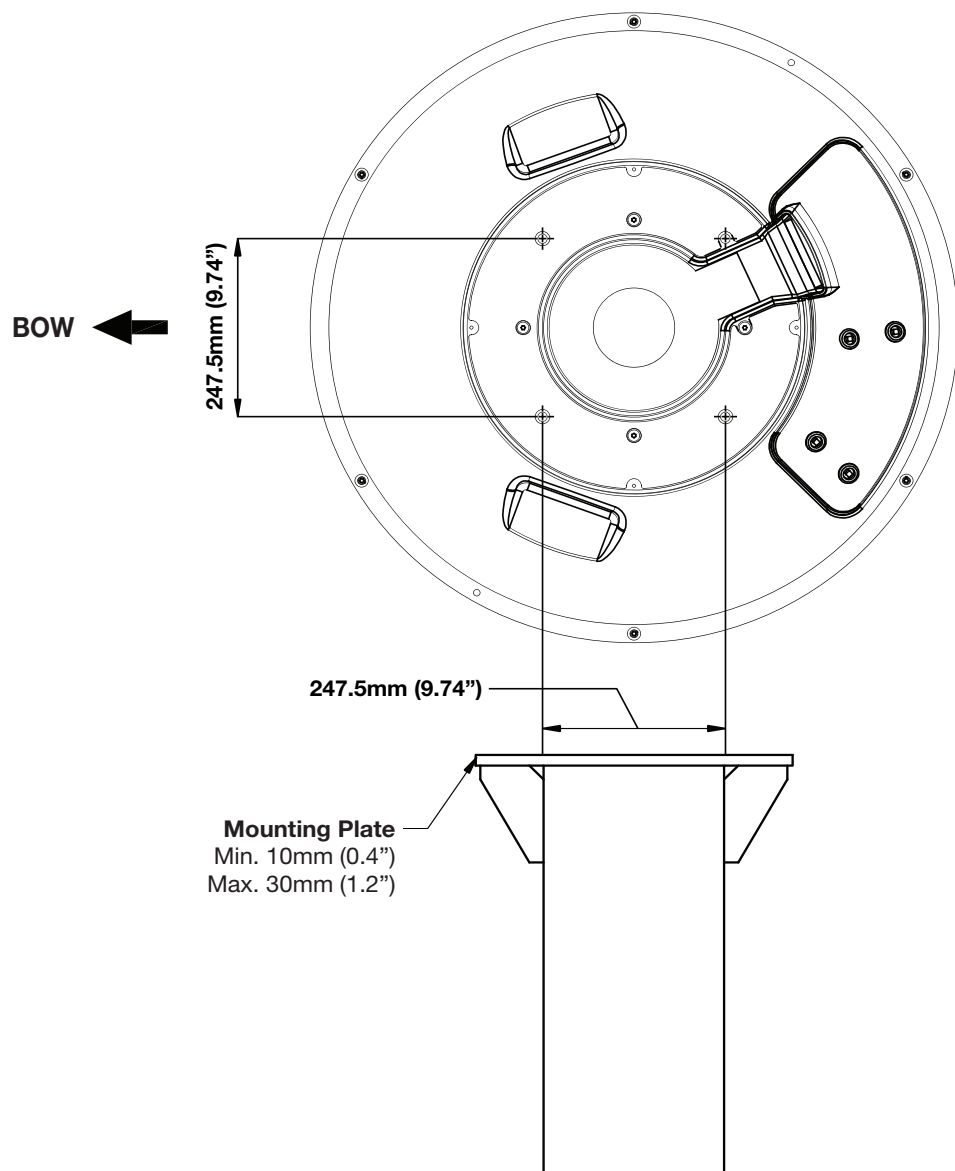

Position the Radome

The radome should be positioned with the BOW marker aligned as closely as possible to the ship's centerline.

Recommended size of the support pedestal

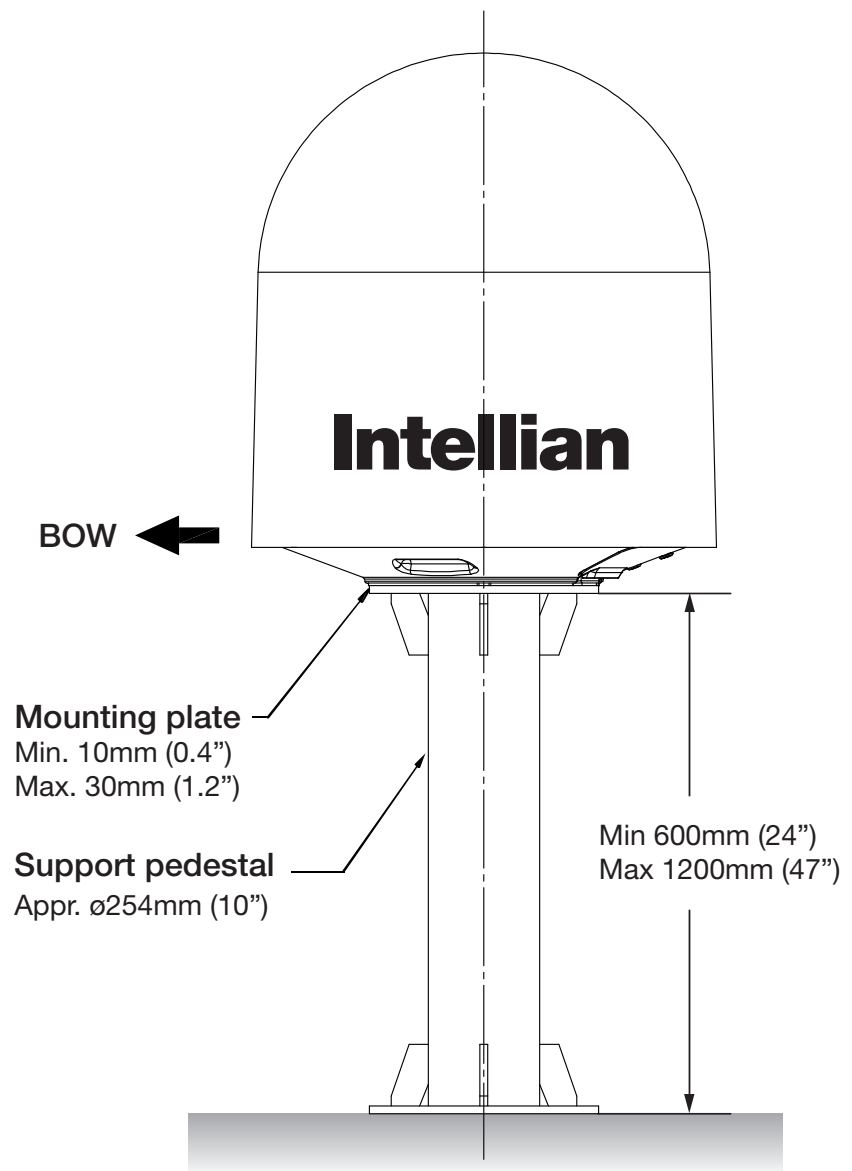

Placing cables on the Mast

The cables must be routed from the antenna and through various areas of the ship to end up at the antenna control unit. When pulling the cables in place, avoid sharp bends, kinking, and excessive force. After placement, seal the deck penetration gland and tie the cables securely in place.

The cable bracket must be installed on the mast to fix the relevant cables.

The gooseneck must be installed on the side of the mast to protect the relevant cables against water.

Option1. Placing the cables on the outside of the mast

1. Place the cables from the gooseneck labeled on the deck to the antenna as shown in the picture below.
2. After connecting the cables to cable connectors inside radome hatch, adjust the cable length and then fix the cables on the cable bracket by using cable ties.

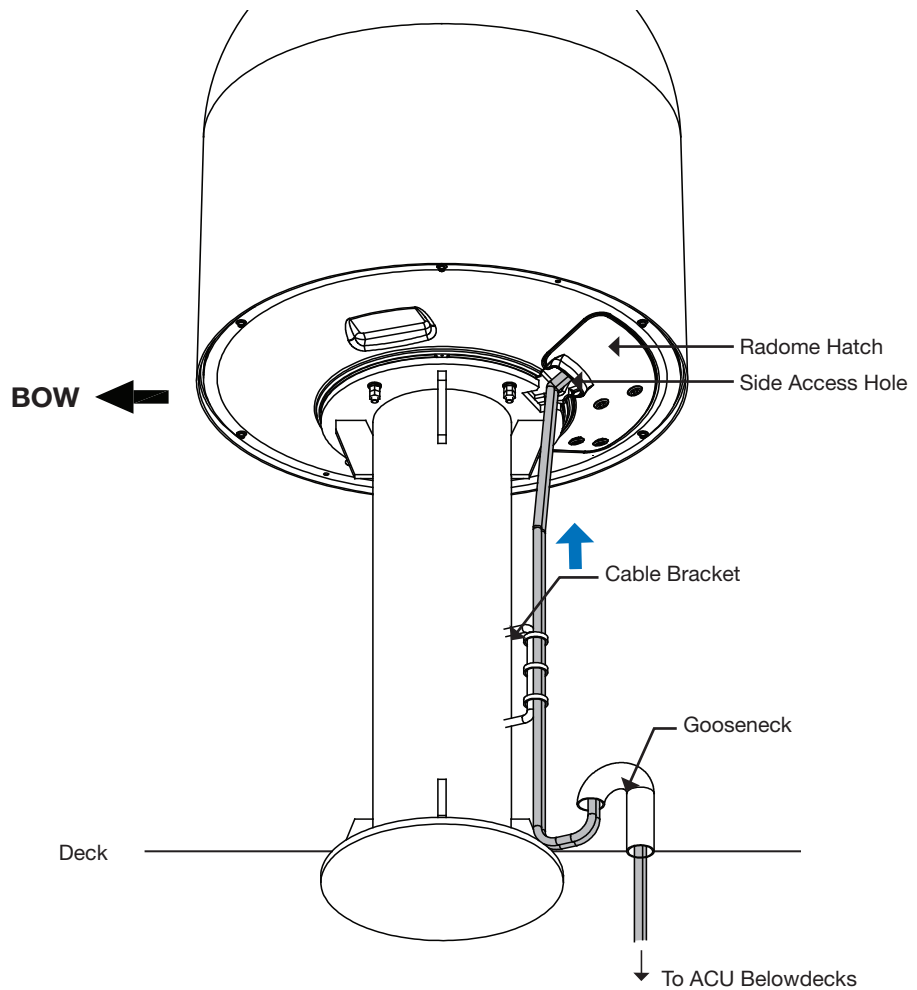



WARNING: Ensure that cables have been run through watertight fittings to prevent water entry into the vessel when installation is completed.

NOTE: When running the cables to the mounting surface, the cables should route through the side access hole to facilitate connecting RF Cables to the antenna.

Option2. Placing the cables on the Inside of the mast

1. Before placing the radome on the mast, the cables should route through the upper gooseneck from the under gooseneck labeled on the deck to facilitate connecting RF Cables to the antenna as shown in the picture below.
2. After connecting the cables to cable connectors inside radome hatch, adjust the cable length and then fix the cables on the cable bracket by using cable ties.

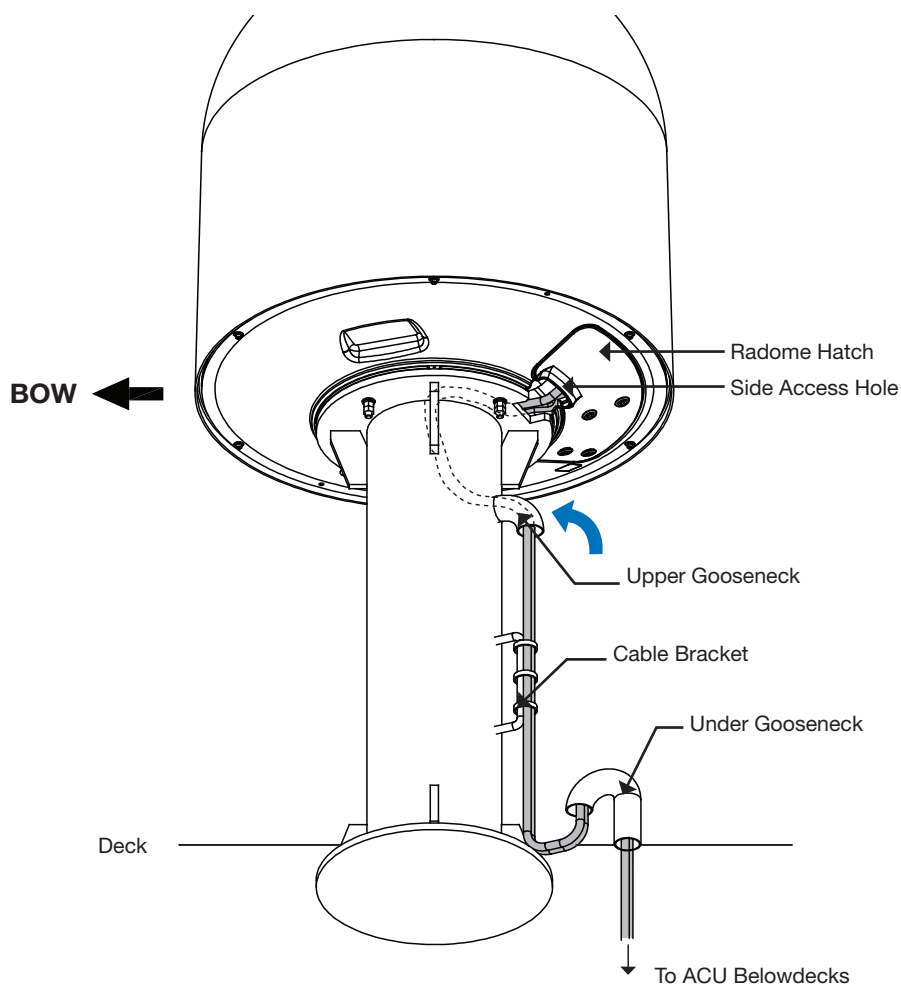

System Cables

Before installing the system cables, you need to take the following points into consideration.

1. All cables need to be well secured and protected from physical damage and exposure to heat and humidity.
2. Cable with an acute bend is not allowed.
3. Where a cable passes through an exposed bulkhead or deck head, a watertight gland or swan neck tube should be used.

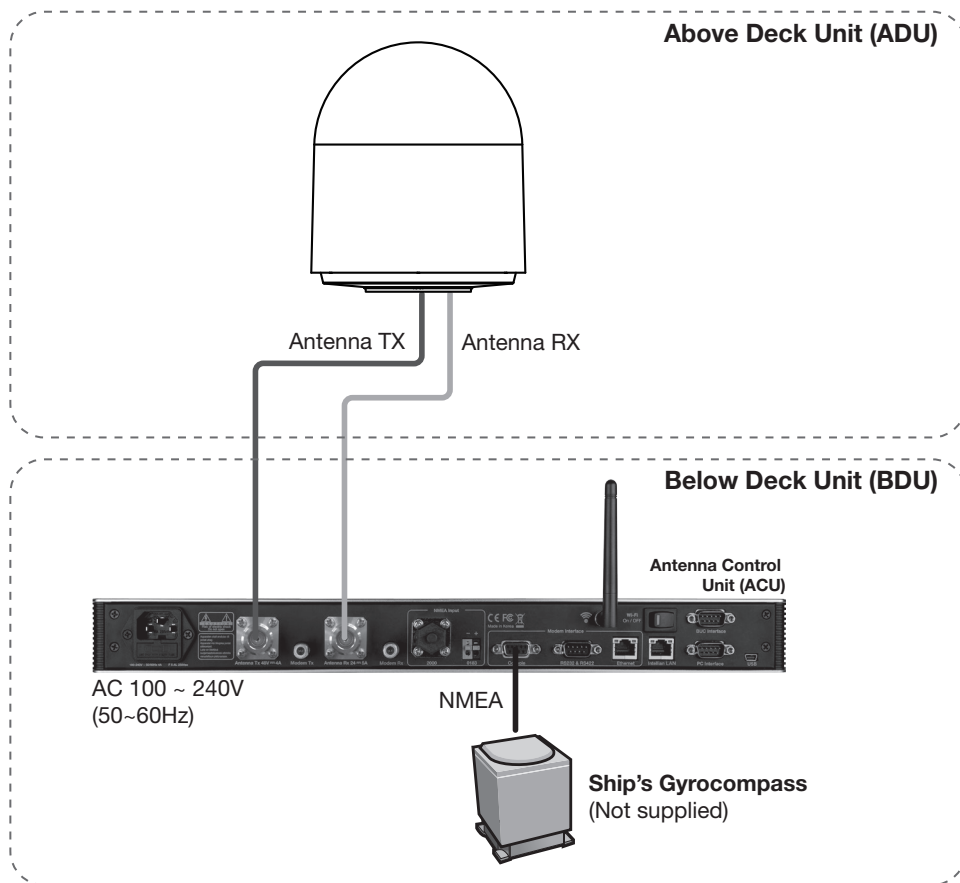

Basic System Configuration

RF Cable (Customer Supplied)

Due to the signal losses across the length of the RF coax on L-Band, Intellian recommends the following 50 ohm coax cable types for standard system installations. For cables that run longer than 100 meters, please consult Intellian Technologies.

Recommended
RF Cables

Coaxial Cable Type	Attenuation in dB/100M	Attenuation in dB/M	Recommended Max Cable Length
LMR400	19.6	0.196	60M
LMR600	12.8	0.128	100M

Antenna Installation

Unpacking the wooden crate

The antenna pedestal is shipped completely assembled in its radome. The pallet should be lifted by means of a suitable sized lifting equipment.

Follow the procedures below.

Step 1.

1. Remove the 16 clips from the edge of the wooden crate by using a flat-head screwdriver.
2. After removing the fixing screw, lift up the top panel.

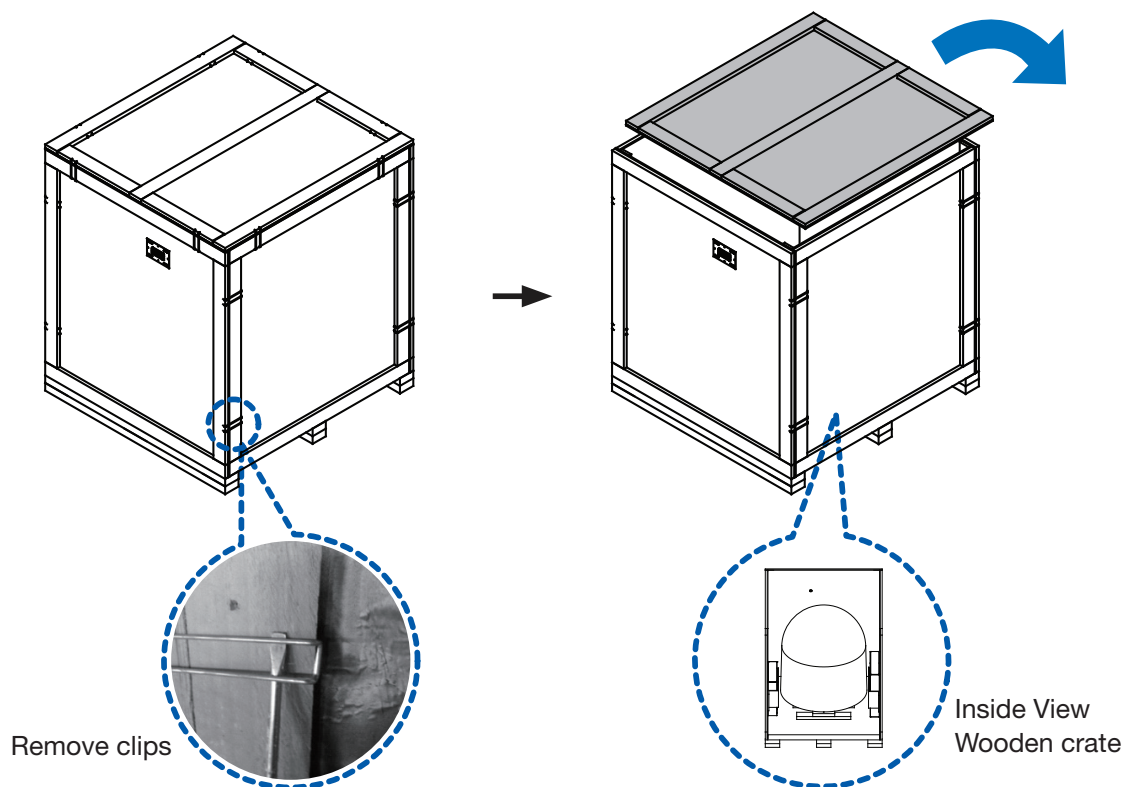

WARNING: Do not remove the side panel fixed with the fixing screw first. Otherwise, the wooden sticks fixed under the top panel may fall and damage the radome inside the wooden crate.

Step 2.

Take out the ACU box and the installation kit box from the wooden crate.

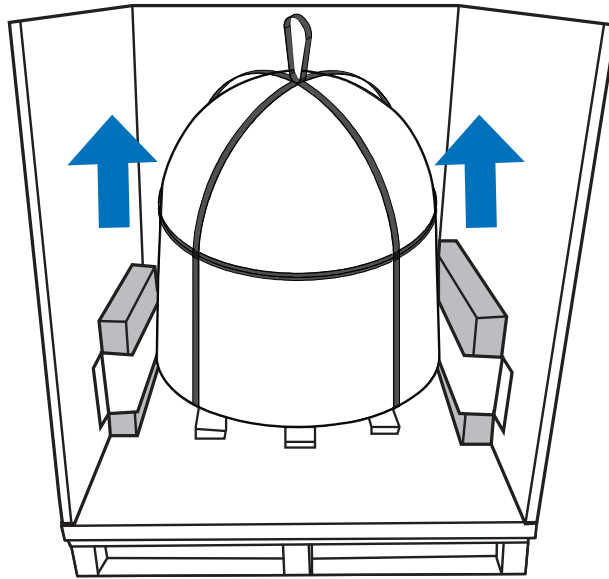

Step 3.

Using 19mm wrench, remove the nuts (4EA) and washers (4EA) that mount the antenna to the pallet.

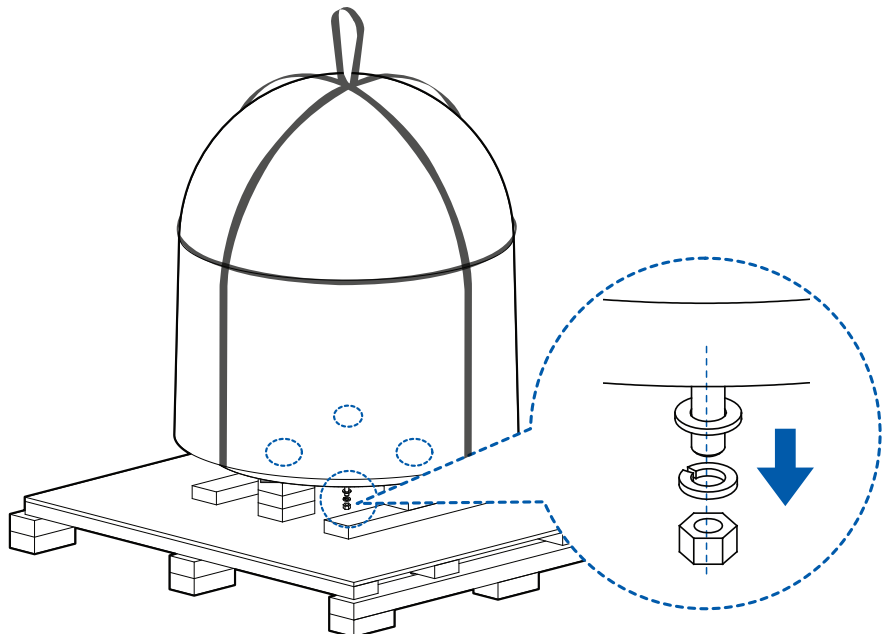

WARNING: When lifting the antenna using the lifting straps, make sure to remove the securing nuts to separate antenna from the pallet.

Placing the antenna on a mast

The Intellian antenna comes with the lifting straps pre mounted from the factory. Check the condition of the lifting strap and that the shackle is tightened up. Ensure the protection is on to avoid damaging the radome.

Lift the antenna above the mast using a crane and carefully place the antenna on the mast.

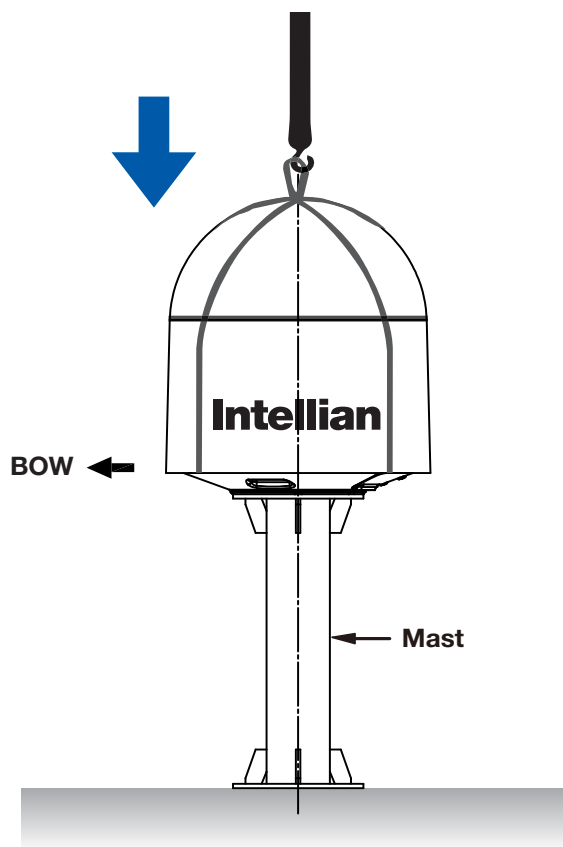

Mounting the Radome

1. Bolt the radome base directly to the support pedestal.

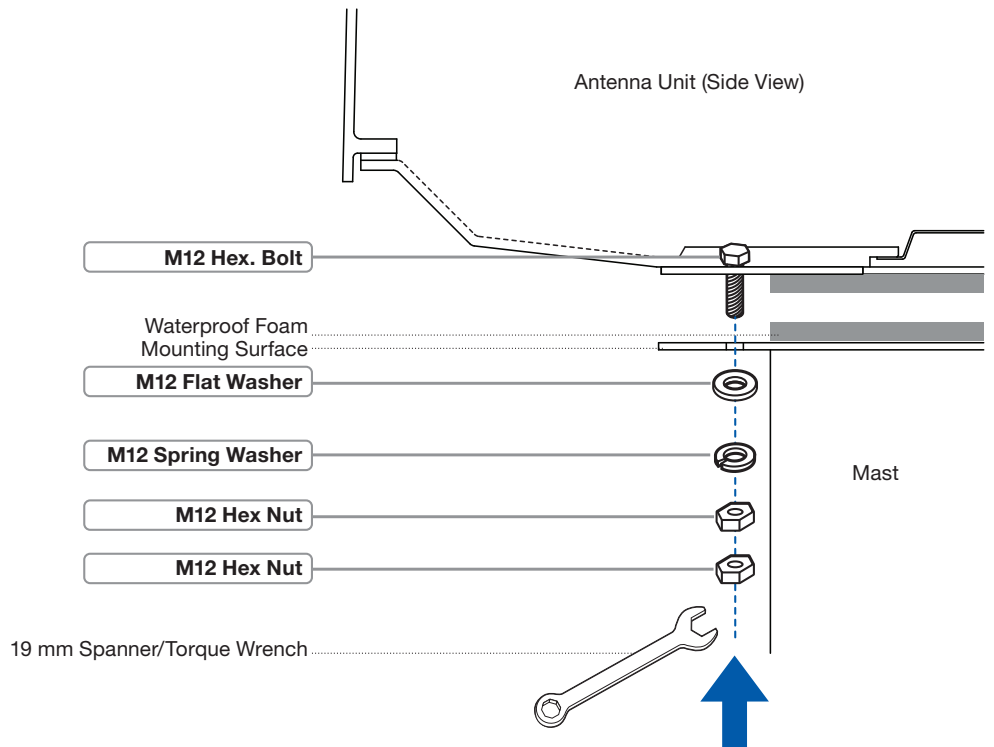

NOTE: Make sure that when you mount the radome, use the tightened bolts on the radome bottom basically. Apply Loctite #262 or equivalent to the bolt thread, and fasten it to a torque setting of 110Nm.

2. Remove the lifting strap.

Connecting RF Cables (Customer Supplied)

Connect the two(2) RF cables to the Antenna RF connectors. Ensure that the power switch is off during the installation period. When all the hardware and cables have been installed, turn on the power switch.

After connecting, seal the cable gland and tie the cables securely in place.

1. Unlock and open the radome hatch by using the radome door key.

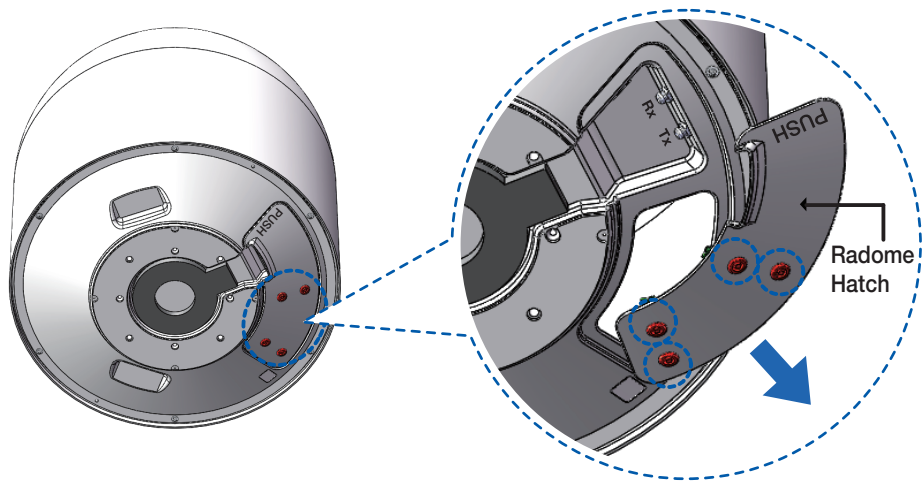

- The Antenna RF connectors are labeled TX and Rx for easy installation. Connect the “Tx” RF cable to the Tx connector and the “Rx” RF cable to the other connector as shown in the figure below. Ensure all cables are firmly fastened to the connectors.

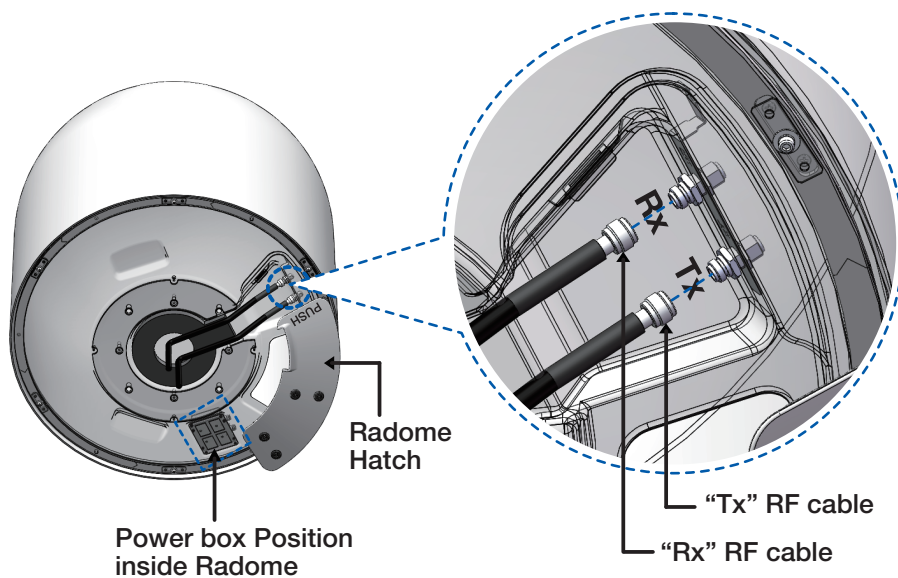

NOTE:

- If the antenna has to connect to a cable thicker than LMR600, please consult Intellian Technologies.
- Ensure that the switch on the power box inside the radome is off during the installation period. The power box is located on right side of the radome hatch. When all the cables have been installed, turn on the switch.

CAUTION: Please ensure that the Tx and Rx cables are correctly connected to the each Tx/Rx connector on the antenna. Failure to connect these correctly will cause system damage.

3. After completing cable connections, close and lock the radome hatch. To lock the radome hatch securely, push on the left side of the radome hatch labeled "PUSH".

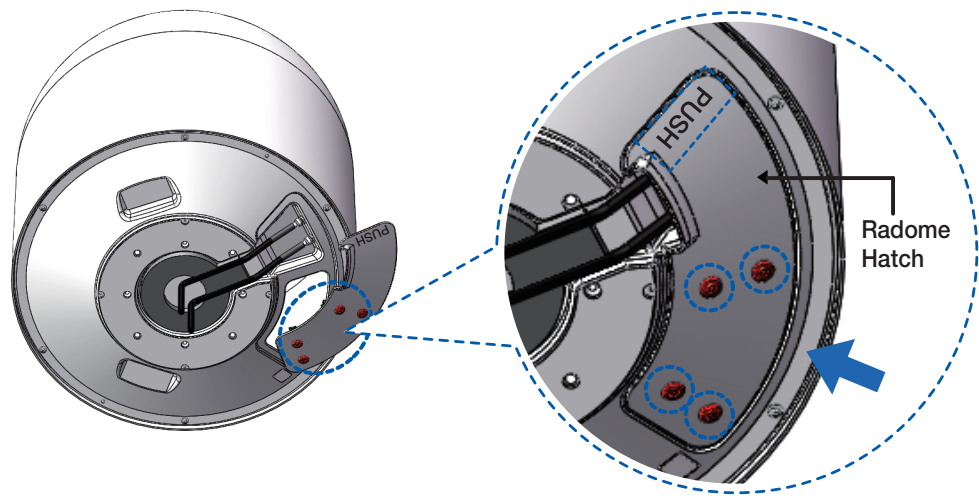

INSTALLING THE ACU

Mounting the ACU

19" Rack Mount Type

Table Mount Type

ACU Dimensions

Selection of ACU Installation Site

Connecting Cables to the ACU

RF Cable Connection

Ship Gyrocompass Connection

Recommended Cable

ACU Connector Guide

PC to ACU Communication Setup

Wi-Fi Connection

Mounting the ACU

Intellian supplies two types of ACU mounting methods (a) 19" Rack Mount Type and (b) Table Mount Type.

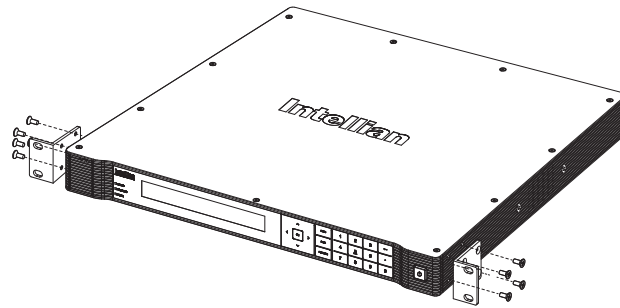

19" Rack Mount Type

- The ACU should be installed using the two supplied Rack Mounting Brackets which allow for a side 19" rack mounting configuration.
- Using the Flat Head screws supplied, attach the mounting brackets to the sides of the ACU.
- Place the ACU in the location where it is going to be installed.
- Connect the cables to the rear of the ACU.

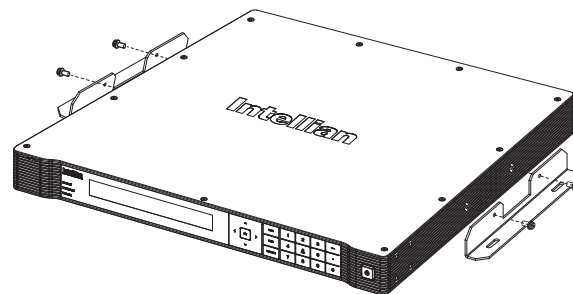

Table Mount Type

- The ACU should be installed using the two supplied Table Mounting Brackets which allow for a top or bottom mounting configuration.
- Using the Sems Bolts supplied, attach the mounting brackets to the sides of the ACU.
- Place the ACU in the location where it is going to be installed.
- Using a pencil to mark the 4 hole positions (2 on each side), and use the appropriate drill bit to screw down the brackets.
- Connect the cables to the rear of the ACU.



WARNING

WARNING: Ensure that the cables connected to the ACU are long enough to prevent damage when the ACU is pulled out from the rack.

ACU Dimensions

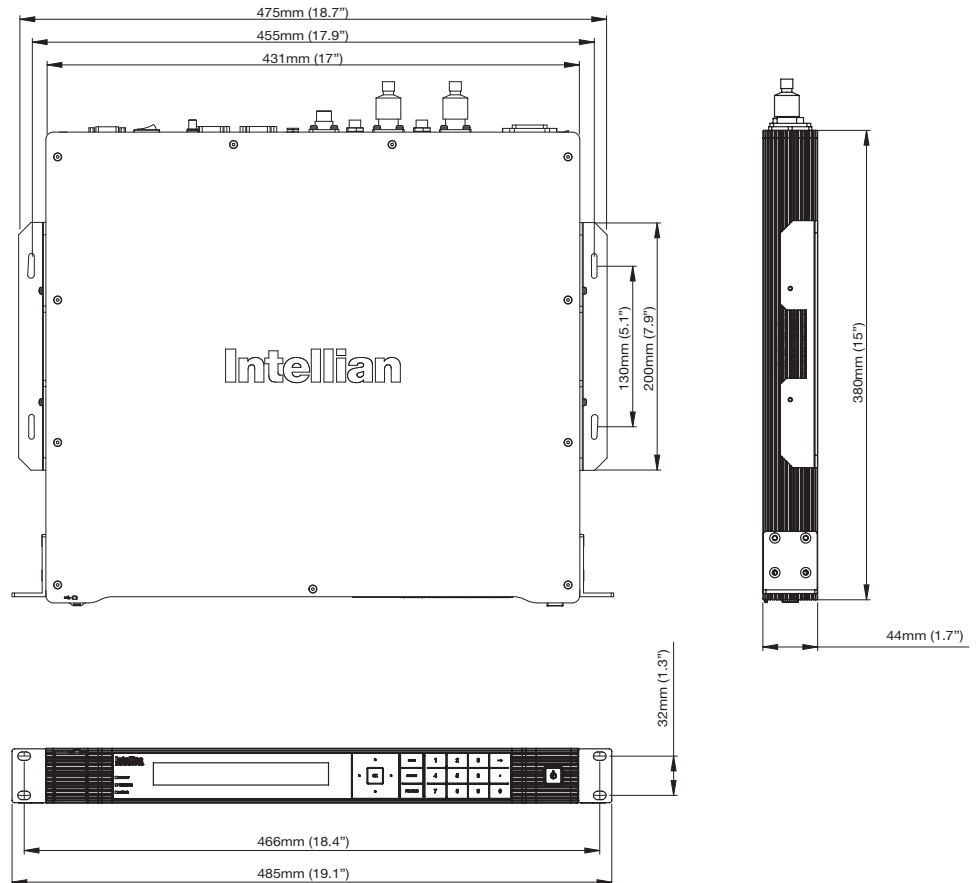

Selection of ACU Installation Site

The ACU should be installed below deck, in a location that is:

- Dry, cool, and ventilated.
- The front panel should be easy to access.

Connecting Cables to the ACU

RF Cable Connection

Connect the two(2) Antenna RF cables to the Antenna RF connectors on the rear of the ACU. Connect the Antenna "Tx" Cable to the "Antenna Tx" connector and the Antenna "Rx" Cable to "Antenna Rx" connector.

Connect the two(2) Modem RF cables to the Modem RF connectors on the rear of the ACU. Connect the Modem "Tx" Cable to the "Modem Tx" connector and the Modem "Rx" Cable to "Modem Rx" connector as shown in the figure below.

Ensure all cables are firmly fastened to the connectors.

NOTE: If the antenna has to connect to a cable thicker than LMR600, please consult Intellian Technologies.

CAUTION: Please ensure that the Tx and Rx cables are correctly connected to the each Tx/Rx connector on the ACU. Failure to connect these correctly will cause system damage.

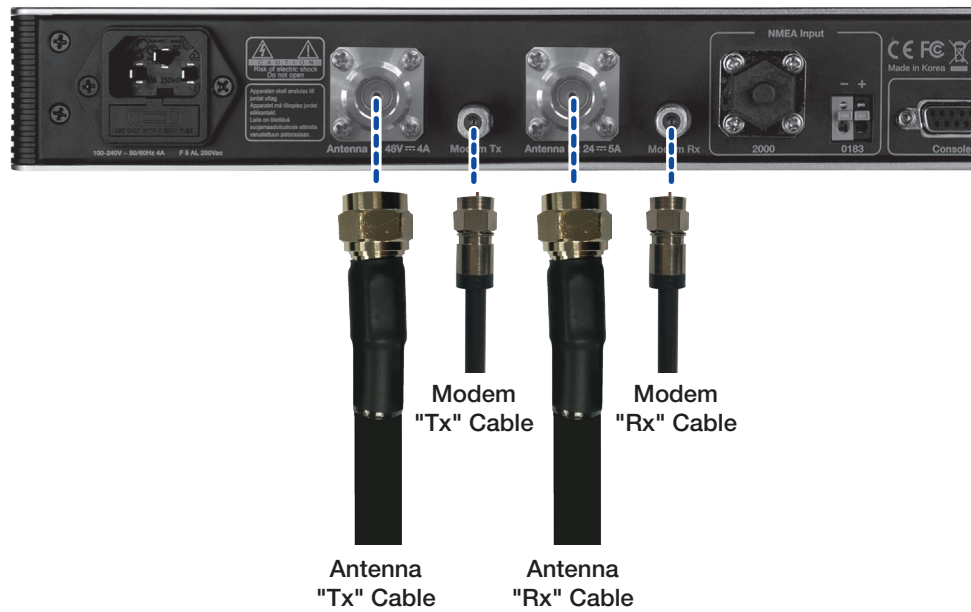

Ship Gyrocompass Connection

The ship's gyrocompass provides true heading input to the antenna allowing the antenna to target and acquire the desired satellite. Intellian always recommends connecting a ship's gyrocompass to the antenna using the gyrocompass interface on the ACU. If the ship's gyrocompass output is other than NMEA 0183 or NMEA 2000, the purchase of an NMEA converter may be required. THDs (Transmitting Heading Devices) that are approved for carriage on certain classifications of a vessel or a GPS compasses with a compatible NMEA output and heading sentence can be also used.

Recommended Cable

- NMEA 0183 Gyrocompass Interface Cable (Customer supplied)
- Connector Type: 2 conductors for NMEA 0183, Mini-C 5 pin for NMEA 2000
- NMEA heading sentence: xx HDT (4800 Baud, 8, N,1) If there is no HDT sentence then use HDM sentence instead.
- NMEA 2000 heading PGN Number = 127250 (Vessel Heading)



ACU Connector Guide

- Console Port

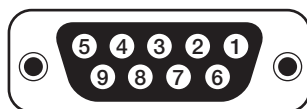

ACU Console Port
D-Sub 9 pin Female

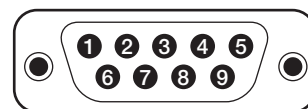

D-Sub 9 pin Male connector
Supplied Component

Pin	Signal	Pin	Signal
1	GND	6	GPS OUT -
2	GPS OUT +	7	MODEM_SIGNAL_IN
3	MODEM_LOCK	8	MODEM_CTRL2
4	MODEM_CTRL1 (TX MUTE)	9	GPS IN -
5	GPS IN +		

NOTE: NMEA GPS IN/OUT Sentence: GPGLL (4800 Baud, 8, N, 1)

- RS232 / 422 Connector (Modem & BUC Interface)

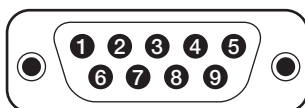

D-Sub 9 pin RS232
Connector

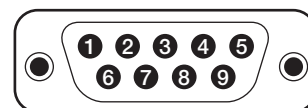

D-Sub 9 pin connector
Supplied Component

Pin	Signal	Pin	Signal	Pin	Signal	Pin	Signal
1	-	6	-	1	-	6	-
2	RXD	7	-	2	RXD +	7	RXD -
3	TXD	8	-	3	TXD +	8	TXD -
4	-	9	-	4	-	9	-
5	GND			5	GND		

• **NMEA 2000 Connector**

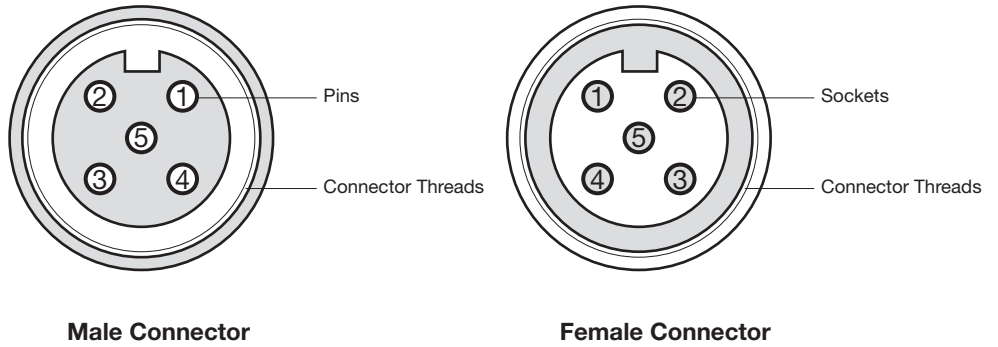

Pin	Signal	Pin	Signal
1	Shield	1	Shield
2	NET-S, (power supply positive, +V)	2	NET-S, (power supply positive, +V)
3	NET-C, (power supply common, -V)	3	NET-C, (power supply common, -V)
4	NET-H, (CAN-H)	4	NET-H, (CAN-H)
5	NET-L, (CAN-L)	5	NET-L, (CAN-L)

NOTE: The connector type of NMEA2000 is a Mini-C 5-pin.

PC to ACU Communication Setup

You can establish data communication between a PC and the ACU using one of the following methods.

TCP/IP Connection

Connection through Front Panel Management Port

This method is most recommended. The network is automatically configured by DHCP without the need of additional PC IP configuration.

Management Ethernet Port

1. Connect an Ethernet cable from a PC Ethernet port to the Management port on the front of the ACU.
2. The network connection is established.
3. Use the following IP address to access Intellian Aptus® or Aptus Web page.
 - **192.168.2.1 (Default)**



Connection through Rear Panel Ethernet Port

This method requires separate IP configuration on a PC.

- Ethernet Port**
1. Connect an Ethernet cable from a PC Ethernet port to an available LAN port of a Switch/Hub.
 2. Go to Control Panel > Network and Sharing Center > Change Adapter Settings and right-click on the Local Area Connection then click Properties
 3. Select TCP/IPv4, then click Properties.
 4. Change the network settings on a PC;
 - **IP: 192.168. 0.222 (Secondary: 10.10.1.2)**
 - **Subnet Mask: 255.255.255.0**
 - **Gateway: 192.168.0.223 (Secondary: 10.10.1.1)**
 5. Use the following IP address to access Intellian Aptus® or Aptus Web page.
 - **Default: 192.168.0.223 (Secondary: 10.10.1.1)**



USB/Serial Connection

Connection through USB Port

There are two USB (USB-to-Serial) ports available on the ACU. One is on the front and the other is on the rear.

- USB Connection
1. Connect a USB cable from a USB port on your PC to the upper USB port on the ACU.



Connection through Serial Port

- Serial Connection
1. Connect a 9-pin Serial cable from the PC Interface connector on the ACU to the 9-pin serial port on your PC.
 2. If there is not a 9-pin serial port on the PC, use a USB-Serial adapter.



Wi-Fi Connection

Setup Wi-Fi Connection

- Setting up the ACU in order to access Wi-Fi
- Setting up the PC (Access Point Mode) in order to access Wi-Fi
- Aptus Web Confirmation

Setting up the ACU in order to access Wi-Fi

1. Turning on the Wi-Fi switch

Turn on the switch on the back of the ACU, and 30 seconds after enabling the power supply, confirm if a red light appears on the switch.

Wi-Fi Quick Reference:

- **SSID: Intellian-TVRO**
- **PW: Intellian1234**
- **PC IP: 192.168.1.222**
- **Subnet Mask: 255.255.255.0**
- **GateWay: 192.168.1.223**



Setting up the PC in order to access Wi-Fi

1. Setting up my computer's wireless IP address

- Control Panel > Network and Sharing Center > Change Adapter Settings > Right click on the "Local Area Connection" > Click Properties

After selecting TCP/IPv4, click on the properties menu, then select "Obtain an IP address automatically."

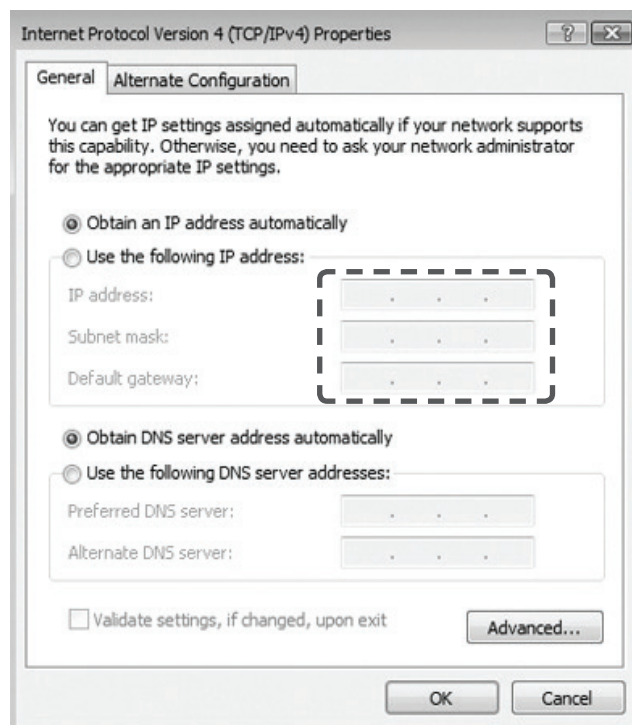

2. To manually change the network settings, click on "Use the following IP address" and use the settings listed below.

Case #1

If iARM Module's IP is known

The iARM module's default IP is **192.168.1.223**

PC IP: 192.168.1.222

Subnet Mask: 255.255.255.0

GateWay: 192.168.1.223

Case #2

iARM Module's IP is unknown

The iARM module's secondary IP is **10.10.10.1**

PC IP: 10.10.10.2

Subnet Mask: 255.255.255.0

GateWay: 10.10.10.1

3. Connect Wi-Fi in AP mode.

After clicking on the Windows Wireless Connection icon, click on intellian-VSAT (Default).

4. Enter the Network Security Key.

Key: intellian1234 (Default)



5. You can confirm the logo and version data by accessing <http://192.168.1.223>

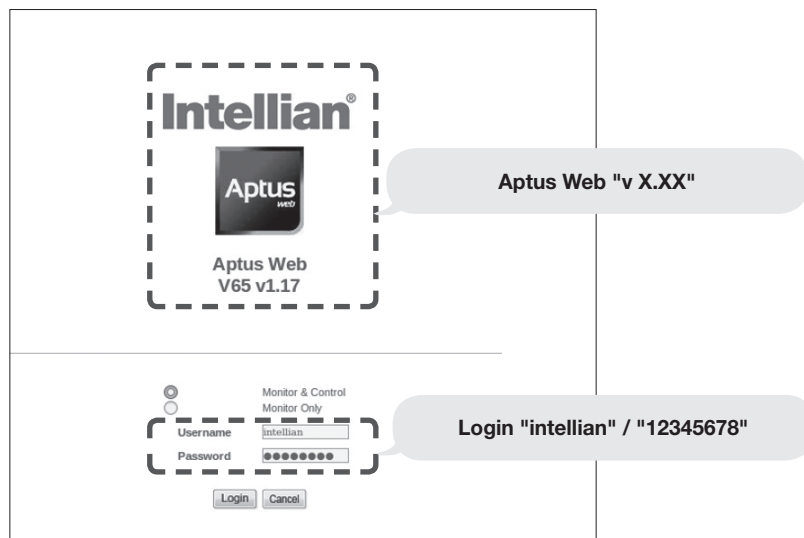

Login by entering the ID / Password listed below.

Username: intellian (Default)

Password: 12345678 (Default)

6. When you login, make sure that all the data within every page is being displayed correctly.

OPERATING THE ACU

Introduction

Normal Mode

Startup

Monitoring Antenna Current Status

Setup Mode

Installation Settings

Antenna Settings

Manual Search

Setup Antenna LNB pol Angle

Search Parameters

Search 1 (Gyro Free) Search Pattern

Search 3 pattern

Setup Antenna Parameters

Setup Block Zone

Antenna Diagnostic Test

Satellite Settings

Load Satellite

Edit Satellite Information

Add Satellite Information

Check NID

System Settings

Set LNB Local Oscillator Frequency

Set Location

Set Modem Port

System Management

Key Lock / Password Management

Introduction

This section of the handbook describes how to set up your system after installation using the ACU.

The functions of the ACU are as follows:

- System startup
- Setting the target satellite
- Editing satellite information
- Setting the antenna parameters
- Setting the antenna manual search
- Setting the LNB local frequency
- Setting radiation hazard or blockage zone
- Setting modem connections
- Setting GPS and Gyrocompass
- Display power status
- Performing real-time diagnostic tests
- Backup and restore the system settings
- Set up the interface with a PC
- Supports Wi-Fi ACU operation
- Recording antenna activities and firmware upgrade through USB
- Built-in web-based remote control management (Aptus)
- Front panel Management Ethernet port

ACU Soft Keys

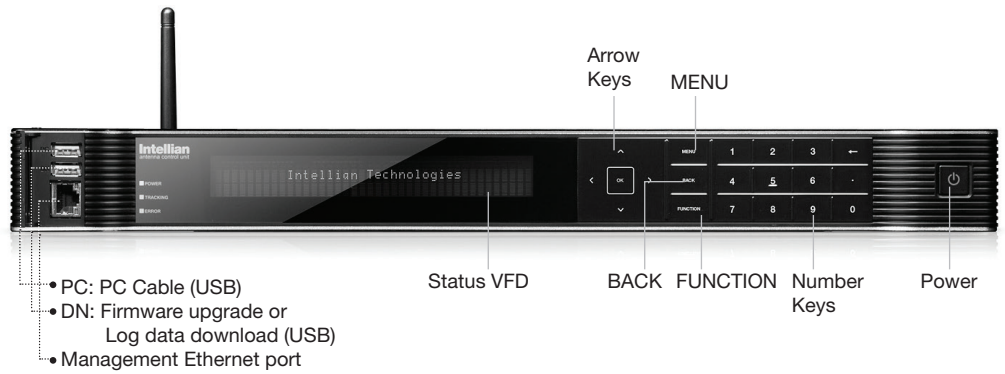

Soft Key Functions

Soft key	Function
MENU	Enter SETUP mode
BACK	In SETUP mode: returns to the previous menu / option or save the adjusted settings. In normal mode: returns to the first page of the antenna's current status.
FUNCTION	Save the adjusted settings.
ARROW KEYS	Select from the alternative options to increase or decrease the selected character to the desired value.
OK	Enter the next step / menu
NUMBER KEYS	Input the numbers



WARNING: Please ensure that your Intellian system is ALWAYS powered ON upon leaving the dock. Failure to follow these instructions could result in damaging mechanical parts in the antenna and/or possibly void your warranty. Intellian strongly recommends restraining the antenna pedestal properly while underway when power is removed from the antenna. The normal operating condition is to remain powered up at all times.

Normal Mode

Startup

With the system installed and power applied, the ACU screen will show the following sequence.

Start up	INTELLIAN TECHNOLOGIES INC.
	1. The data communication is being established between the antenna and the ACU.
Initialize antenna info	INITIALIZE – ANTENNA INFO INTELLIAN V65
	2. The ACU receives antenna information.
Initialize elevation & cross level angle	INITIALIZE – EL POSITION INTELLIAN V65
	3. The elevation angle and cross level angle are initialized.
Initialize azimuth angle	INITIALIZE – AZIMUTH POSITION INTELLIAN V65
	4. The azimuth angle is initialized.
Initialize target satellite position	INITIALIZE – SAT POSITION INTELLIAN V65
	5. The antenna returns to the target satellite position.
Search status	↵ SEARCH1 138.0E TELST_18 SIG: 301 VL ↵ AZ: 292.7 (202.7) EL: 48.3 SK: -72.0
	6. The antenna is searching for the target satellite.
Tracking status	↵ TRACKING 138.0E TELST_18 SIG: 501 VL ↵ AZ: 292.7 (202.7) EL: 48.3 SK: -72.0 Fn
	7. The antenna has locked onto the satellite.

Monitoring Antenna Current Status

When the ACU power is on, it displays the status of the antenna. The current status of the antenna is displayed as shown below.

Current search status

```

# SEARCH1 138.0E TELST_18 SIG: 301 VL #
  AZ: 292.7 ( 202.7) EL: 48.3 SK: -72.0
    
```

1. The antenna is searching for the target satellite.

Current tracking status

```

# TRACKING 138.0E TELST_18 SIG: 301#VL #
  AZ: 292.7 ( 202.7) EL: 48.3 SK: -72.0 Fn
    
```

2. The antenna has locked onto the target satellite.

Current IF signal level (SIG/AGC) is displayed. SIG will be displayed when NBD (Narrow band detection) mode for TRACKING SIGNAL is chosen to be used and AGC will be displayed when DVB mode of TRACKING SIGNAL is chosen to be used.

The symbol "#" will be only displayed when the satellite signal is strong enough to be locked onto. [VL] indicates the LNB's local frequency corresponding to 13V is in use for the signal reception.

VL: 13V + 0 kHz, HL: 18V + 0 kHz, VH: 13V + 22 kHz, HH: 18V + 22 kHz

True azimuth [292.7] position of the antenna is the sum of ships heading 090.0 [HDG] and antenna relative [202.7].

NOTE: However, if the "GYRO TYPE" is set to "NONE" or "NMEA" but without receiving a proper input signal, "---." will be displayed at "True Azimuth"

Save current satellite info

```

          SAVE CURRENT SAT INFO ?
        + YES                               NO
    
```

3. Press FUNCTION key to save current satellite information or abort and return to the main display. "Fn" will be displayed only if the antenna is in tracking mode.

```

# TRACKING 138.0E TELST_18 SIG: 301#VL #
  AZ: ---. - ( 202.7) EL: 48.3 SK: -72.0 Fn
    
```

4. Press RIGHT arrow key to display Narrow Band Detection (NBD), GPS and ship's heading information.

Tracking & Heading information

```

┌ NBD      F: 1247000  BW: 1000  SIG: 301# ┐
└ 004.53E  52.22N  HDG: 090.0  L: 10000 Fn ┘
    
```

5. NBD, GPS and ship's heading information are shown.
 - NBD IF tracking frequency: 1247000 kHz
 - Detected Band Width: 1000 kHz
 - SIG (Signal Level): 301 (When NBD mode for tracking signal is chosen)
 - W (West)/E (East) Longitude: 4.53° E
 - N (North)/S (South) Latitude: 52.22° N
 - HDG (Ship's Heading): 90°
 - LNB local oscillator (LO) frequency: 10000 MHz

Power status

```

┌ [PWR] ANT: 26.4V  LNB: 13V + 0kHz ┐
└ ACU: 27.1V  [POL] TX: V  RX: H ┘
    
```

6. Press RIGHT arrow key to display the current operation voltage for antenna, ACU and LNB. POL indicates the TX polarity (VERTICAL) and RX polarity (HORIZONTAL).

Antenna & ACU versions

```

┌ V2-81-CFW  ANT. SERIAL  1.00/1.00 ┐
└ VP-T529   ACU SERIAL   1.00 ┘
    
```

7. Press RIGHT arrow key to display the below information.
 - Antenna part number, antenna serial number and PCU firmware version.
 - ACU part number, ACU serial number, and ACU firmware version.
 Press BACK Key to return to the first page of the antenna current status.

Select USB functions

```

┌ [USB FUNCTION]  SELECT USB FUNCTION ┐
└                UPGRADE FIRMWARE ┘
    
```

8. Touch RIGHT arrow key to display the **USB FUNCTION***
 This menu will be displayed automatically if a USB flash drive is plugged into the lower USB port located in the front panel of the ACU.

USB FUNCTION*

- UPGRADE FIRMWARE: upgrade the system by using the firmware files (files format: *.FWP) from the specified folder in the USB flash drive.
- COPY LOG DATA: Copy the up-to-date log data from the system to the USB flash drive.



Upgrade the system

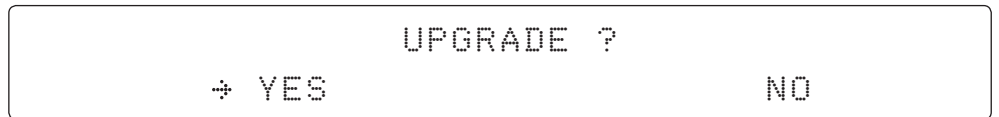

9. Touch OK key to upgrade firmware.

Refer to the error messages below if any errors occur.

UPGRADE FIRMWARE

- FIRMWARE FILE NOT FOUND: the system cannot find the FWP file.
- INVALID FIRMWARE: the file is not in a recognizable FWP format.
- MORE THAN 1 FILE EXIST: there is more than 1 firmware file that exists in the specified folder in the USB flash drive.
- CHECK USB CONNECTION: the USB flash drive is not connected.

COPY LOG DATA

- COPY LOG DATA TO USB [30%]: display the copy progress in percentages.
- NOT ENOUGH SPACE IN USB: USB is out of memory
- CHECK USB CONNECTION: the USB flash drive is not connected.

Real-time diagnostic result

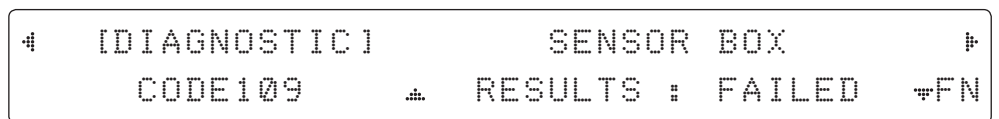

10. Press RIGHT arrow key to display the real-time diagnostic result.

The real-time diagnostic code will be displayed automatically if there is any error found during the system operation. However, this page will not be displayed if there is no error message.

Erase Error message

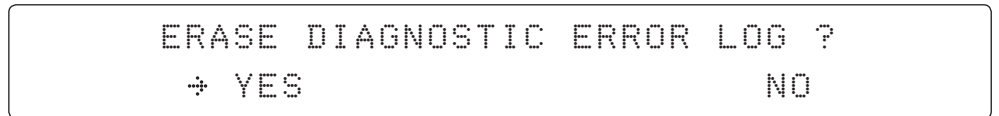

11. Press LEFT arrow key to move cursor to YES and press the OK key to erase the diagnostic error message.

Setup Mode

Follow instructions below to enter SETUP mode.

Searching / Tracking mode

```
⌘ TRACKING 138.0E TELST_18 SIG: 301 VL ⌘  
AZ: 292.7 ( 202.7) EL: 48.3 SK: -72.0 Fn
```

1. While the antenna is in SEARCHING / TRACKING mode, press MENU key to enter SETUP mode. * indicates the key pad lock function is on (Refer to KEY LOCK menu to setup the key pad lock function). When key pad lock function is activated press MENU key or when "Fn" menu is activated press FUNCTION key for the ENTER PASSWORD menu to be displayed.

Enter password

```
ENTER PASSWORD  
- - - -
```

2. If the key pad lock function is on, enter the password before accessing to the SETUP mode. If the key pad lock function is off, access to the SETUP mode directly as shown in Step 3.

Setup mode

```
SETUP MODE ?  
→ YES NO
```

3. Press LEFT arrow key to move cursor to YES and press OK key to enter SETUP mode or press RIGHT arrow key to move cursor to NO and press OK key to abort and return to the main display.

Exit setup mode

```
EXIT SETUP MODE ?  
→ YES NO
```

4. While the antenna is in SETUP mode, press FUNCTION key as shortcut key to exit SETUP mode.

Installation Settings

During the first time installation, it is required to configure the installation settings.

Setup mode

```

                SETUP MODE ?
            ↪  YES                               NO
    
```

Installation menu

```

    +ANTENNA                               +SATELLITE
    +SYSTEM                                 ↪+INSTALLATION
    
```

1. Press LEFT arrow key to move cursor to YES and press OK key to enter SETUP mode

Select satellite

```

                SELECT SATELLITE
            ▲ [1] TELST_18 138.00E ▼
    
```

2. Press arrow keys to move cursor to INSTALLATION menu and press OK key to select it.

3. Press UP and DOWN arrow keys to select the satellite that you wish to track and press OK key to load the selected satellite.

Latitude & Longitude

```

                LATITUDE                               LONGITUDE
            ▲ 37.00N ▼                                126.53E
    
```

4. Set the current LATITUDE and LONGITUDE

- Press LEFT and RIGHT arrow keys until the desired character is underscored (selected).
- Press UP and DOWN arrow keys to increase or decrease the value.
Or press NUMBER keys to set the desired value directly.
- Press OK key to set the parameter.

Gyro type

```

                GYRO TYPE                               BOW OFFSET
            ▲  NMEA ▼                                000
    
```

5. Set the ship's **GYRO TYPE*** & **BOW OFFSET**.

A search pattern 1 or 3 will be initiated according to which Gyro Type is selected and the existence of the gyro input. Ensure that the supported Gyro Type is set correctly. If the ship's gyrocompass output is other than NMEA0183 and NMEA2000, a separate purchase of an NMEA converter is required.

A search pattern 1 will be initiated automatically if the gyro input does not exist and the gyro type is selected other than GROUND TEST.

The BOW OFFSET is to offset the angle difference between the antenna's bow and the ship's bow (Range: 0 – 360°).

NOTE: The bow offset will not be saved automatically if Search 1 pattern is initiated. In this case, the antenna will need to retarget the desired satellite using Search 1 every time if the antenna restarts.

Connecting the System without a Ship's Gyrocompass

For a vessel where a ship's gyrocompass is not installed or is difficult to connect, the Intellian Gyro-Free satellite search function will be automatically enabled to allow the antenna to lock onto the desired satellite without requiring an external heading input.

The table below provides an example of the Gyro-Free satellite search algorithm. The Search 1 or Search 3 satellite search pattern will be initiated according to the existence of heading input and the setting of the heading device.

Search 1: The antenna will search for the target satellite by turning its azimuth angle in a Counter Clockwise (CCW) direction until the antenna receives a lock signal from the modem or until the Digital Video Broadcast (DVB) transponder of the target satellite is decoded by the antenna.

Search 3: The antenna will search for the target satellite by turning its azimuth angle directly to the position calculated using the ship's heading source and lock onto the satellite.

Gyro search mode

Existence of Heading Data	Setting of Heading Device		
	No Device	NMEA / NMEA 2000	Ground Test
w/ Heading Data	Search 1	Search 3	Search 3
w/out Heading Data	Search 1	Search 1	Search 3

GYRO TYPE*

NO DEVICE
 NMEA / NMEA 2000
 GROUND TEST

Quick Setup Procedure

- Set the satellite with a DVB transponder as the target satellite.
- Select "No Device" as the heading device.
- The antenna will search for the target satellite by rotating the azimuth angle in a CCW direction and will track the satellite when a lock signal is received from the modem.
- Set the heading device as NMEA
 - Enter the "Manual search" menu and press the "Function" key to save the current settings. Intellian's ACU will automatically calculate and save the BOW offset.
 - Upload the real TARGET satellite pre-configured from the library.

Modem Type & LNB Local

```

MODEM TYPE                13V + 0kHz
┌ IDIRECT-I/O ─────────── 10000MHz
    
```

6. Set **MODEM TYPE*** and **LNB LOCAL**.

MODEM TYPE is to select a proper data communication port on the ACU to interface with the satellite modem.

MODEM TYPE*

USER SETTING	SATLINK-VACP
IDIRECT-I/O	ELEKTRIKOM-AMIP
IDIRECT-AMIP	GILAT-SE-II
COMTECH-I/O	IPSTAR-SOTM
COMTECH-ROSS	INMARSAT-G5
HUGHES	NEWTEC-AMIP
SATLINK-SEIRAL	

```

18V + 0kHz                13V+22kHz
┌ 10750MHz ─────────── 11300MHz
    
```

```

18V +22kHz
┌ 11300MHz ───────────
    
```

Set the LNB LOCAL oscillator frequency for each voltage power. (13V +0 kHz, 18V +0 kHz, 13V +22 kHz, 18V +22 kHz)

Press LEFT and RIGHT arrow keys until the desired character is underscored (selected). Press UP and DOWN arrow keys to increase or decrease the value. Or press NUMBER keys to set the desired value directly.

Load

```
                                LOAD ?
                                ↵ YES                                NO
```

7. Press LEFT arrow key to move cursor to YES and press the OK key to load the current setting.

Loading settings

```
LOADING ...
DO NOT TURN OFF !      ###00000000
```

8. Setting is being loaded to the system.

The ACU will restart the system automatically after uploading the setting.
DO NOT TURN OFF ACU POWER while the data is being uploaded.

Tracking status

```
4 TRACKING 138.0E TELST_18 SIG: 301# VL ▶
  AZ: 292.7 ( 202.7) EL: 48.3 SK: -72.0 Fn
```

9. Antenna has locked onto the target satellite.

Antenna Settings

Manual Search

Search for the desired satellite manually.

Setup mode

```

                SETUP MODE ?
          ↵ YES                      NO
    
```

1. Press LEFT arrow key to move cursor to YES and press OK key to enter SETUP mode.

Antenna menu

```

    ↵+ANTENNA                      +SATELLITE
      +SYSTEM                      +INSTALLATION
    
```

2. Press OK key to enter ANTENNA menu.

Manual search menu

```

    ⏪ ↵ +MANUAL SEARCH              +SET POL ANGLE  ⏩
      +SEARCH PARAM                +SET PARAMETERS
    
```

3. Press OK key to enter MANUAL SEARCH menu.

Antenna movement

```

STEP SIZE  AZIMUTH  ELEVATION  AGC
# 00.2 #  ⏪ 231.7 ⏩  ⏴ 48.3 ⏵  301 Fn
    
```

4. Current IF tracking signal level (AGC) / (SIG) is displayed to assist you in manually peaking AZIMUTH (0°-360°) and ELEVATION (0°-90°) angle for best signal level.

Press NUMBER key to change the STEP SIZE (Range: 0.1~99.9).

Press LEFT and RIGHT arrow keys to increase or decrease the AZIMUTH angles.

Press UP and DOWN arrow keys to increase or decrease the ELEVATION angles.

Save

```

                SAVE CURRENT SAT INFO?
          ↵ YES                      NO
    
```

5. Press FUNCTION key to save current settings or abort and return to the main display. If the current settings are able to locate the satellite, press FUNCTION key to save "current satellite information". This will help to reduce the satellite acquisition time after restarting the system. Press LEFT arrow key to move cursor to YES and press the OK key to save the settings.

NOTE: If the gyro type is not ground test or the gyro is not connected to the ACU, the information cannot be saved.

Setup Antenna LNB pol Angle

Setup mode

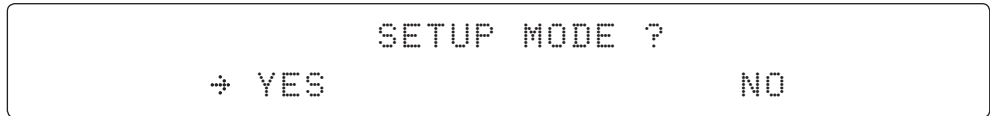

1. Press LEFT arrow key to move cursor to YES and press OK key to enter SETUP mode.

Antenna menu



2. Press OK key to enter ANTENNA menu.

Set pol angle menu

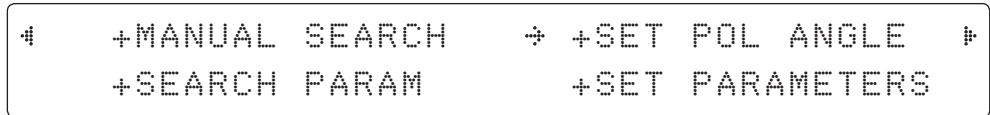

3. Press RIGHT arrow key to move cursor to SET POL ANGLE menu and press OK key to select it.

LNB pol angle type

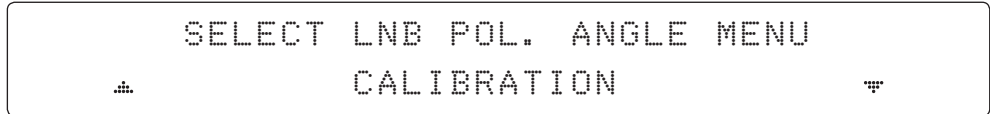

4. Press UP and DOWN arrow keys to select the LNB pol angle menu and press OK key to run one of the selected operations: 'CALIBRATION', 'MANUAL ADJUST' or 'RESET MECHANICAL OFFSET'. Select MANUAL ADJUST to control LNB pol angle manually. If the control board, LNB pol potentiometer or belt is replaced, select CALIBRATION to calibrate LNB pol angle.

LNB pol angle Signal

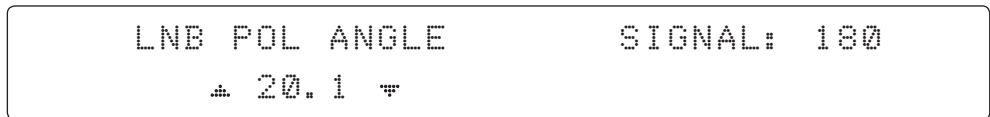

5. Press UP and DOWN arrow keys to increase or decrease the LNB pol angle manually and the corresponding SIGNAL level will be displayed next to it. Press BACK key to return to the main display.

NOTE: LNB POL ANGLE menu will be displayed only if MANUAL ADJUST is selected.

Mechanical Skew Offset

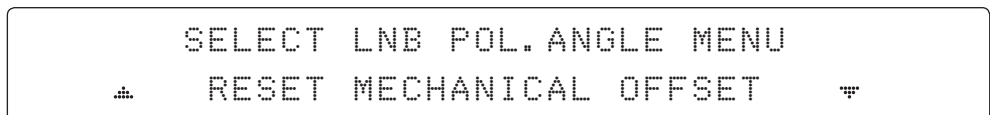

6. Press OK keys to reset the mechanical skew offset.

Search Parameters

Setup mode

```

                SETUP MODE ?
          ↗ YES                               NO
    
```

1. Press LEFT arrow key to move cursor to YES and press OK key to enter SETUP mode.

Antenna menu

```

    ↗+ANTENNA                               +SATELLITE
      +SYSTEM                               +INSTALLATION
    
```

2. Press OK key to enter ANTENNA menu.

Manual search menu

```

    ↖  +MANUAL SEARCH                       +SET POL ANGLE  ↗
      ↗+SEARCH PARAM                       +SET PARAMETERS
    
```

3. Press arrow keys to move cursor to SEARCH PARAM menu and press OK key to select it.

Search param

```

    SEARCH WAIT TIME      INCREMENT STEP
    ↖   030               ↗   0.50
    
```

4. Set SEARCH WAIT TIME and INCREMENT STEP.

Set the time-out for automatic initiation of a search after the signal level drops below the predefined threshold value (Range: 1 - 120 sec) and set increment step size (Range: 0.01 – 5.00 sec)

- a) Press LEFT and RIGHT arrow keys until the desired character is underscored (selected).
- b) Press UP and DOWN arrow keys to increase or decrease the value.
Or press NUMBER keys to set the desired value directly.
- c) Press OK key to set the parameter.

Search 1 range

SEARCH1 AZ	SEARCH1 EL
▲ 400 ▼	06

Search 3 range

SEARCH3 AZ	SEARCH3 EL
▲ 003 ▼	04

5. Set SEARCH 1 and SEARCH 3 AZ (Azimuth) range and EL (Elevation) range. SEARCH 2 is reserved for future use.

A search pattern 1 or 3 will be initiated according to which GYRO TYPE is selected and the existence of the gyro input.

Search 1: a search pattern 1 will automatically be initiated when the ship's heading input does not exist / has failed. The antenna will go to the relative azimuth position 0° at the calculated elevation and search in the azimuth CCW direction and search up +0.5° & down -0.5° with a total 6°(±3°) in elevation. The search cycle will repeat until the antenna receives the lock signal from the modem or the DVB transponder of the target satellite is decoded by the antenna. If the desired signal is found and above the predefined detect level, the ACU will enter to Search 3. In this case, the antenna will not initiate Search 3 pattern and instead it will go into TRACKING mode immediately if the desired signal is above the predefined tracking threshold level. If the detected signal is below the predefined tracking threshold level, the Search 1 will repeat and start 3° away from the current position.

- a) Press LEFT and RIGHT arrow keys until the desired character is underscored (selected).
- b) Press UP and DOWN arrow keys to increase or decrease the value.
Or press NUMBER keys to set the desired value directly.
- c) Press OK key to set the parameter.

Search 1 (Gyro Free) Search Pattern

Target Satellite EL Position

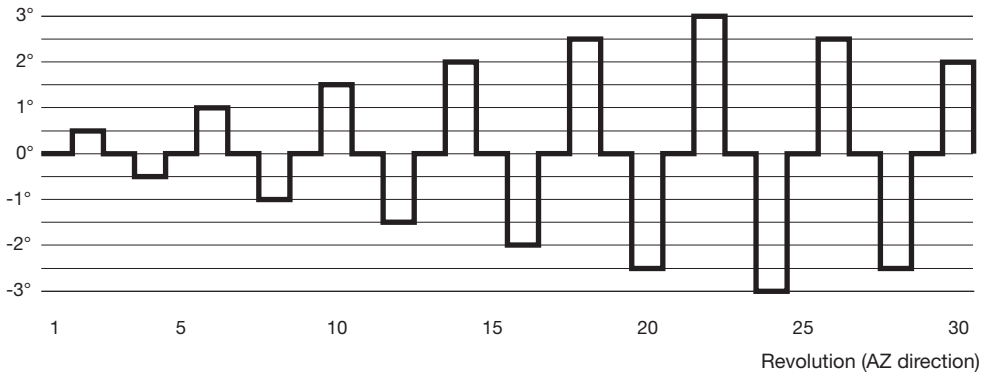

Search 1 antenna motion

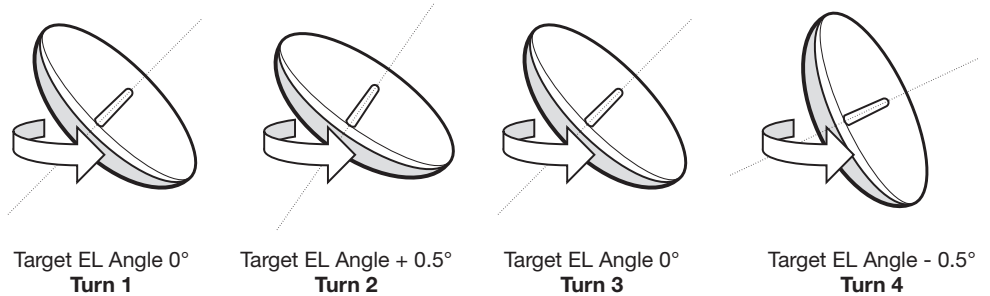

Search 3: a search pattern 3 will automatically be initiated when AGC / SIG falls below the current tracking level threshold value. If the desired signal is found and above the predefined tracking level, the ACU will terminate Search 3 and go into TRACKING mode. A search pattern will automatically be initiated when AGC / SIG falls below the current threshold setting which indicates that satellite signal has been lost. The search is conducted in a two-axis pattern consisting of alternate movements in azimuth (AZ) and elevation (EL) similar to forming an expanding square as indicated in the diagram below.

Search 3 pattern

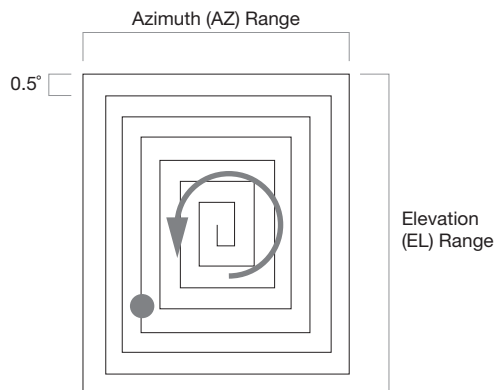

Setup Antenna Parameters

These parameters should only be changed by an authorized service technician. Improper setting of these parameters will cause your system to perform improperly.

Setup mode

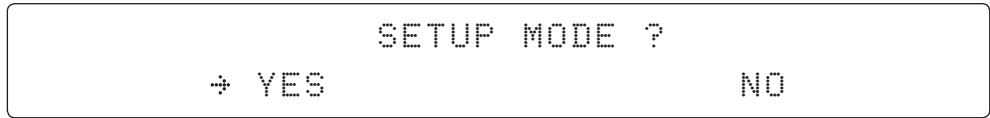

1. Press LEFT arrow key to move cursor to YES and press OK key to enter SETUP mode.

Antenna menu



2. Press OK key to enter ANTENNA menu.

Set parameters menu

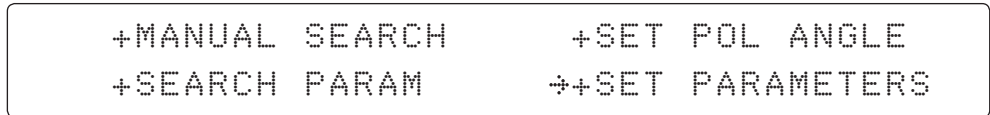

3. Press arrow keys to move cursor to SET PARAMETERS menu and press OK key to select it.

Password



4. Press 4 digit password to enter SET PARAMETERS menu (Default **1590**).
Setup parameters are only required after installation or repairs of your antenna system.

These parameters should only be changed by an authorized service technician. Improper setting of these parameters will render your system inoperable.

Set detect & tracking DVB



5. Set DETECT DVB and TRACKING DVB when DVB mode of TRACKING SIGNAL is used (Range: 1-200).

DETECT DVB is to set the satellite signal detection level and TRACKING DVB is to set the satellite signal tracking level.

- a) Press LEFT and RIGHT arrow keys until the desired character is underscored (selected).
- b) Press UP and DOWN arrow keys to increase and decrease the selected character.
Or press NUMBER keys to set the desired value directly.
- c) Press OK key to set the parameter.
- d) Press BACK key to select the parameter you wish to edit and press BACK key again to save or abort and return to the main display.

Set detect & tracking NBD

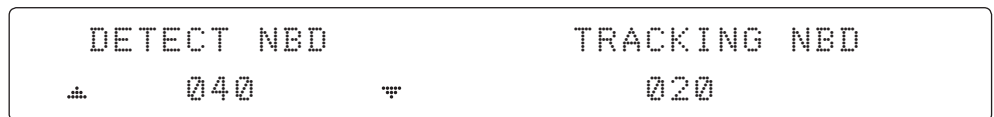

6. Set DETECT NBD and TRACKING NBD when NBD (Narrow band detection) mode of TRACKING SIGNAL is used (Range: 1-200).

DETECT NBD is to set the satellite signal detection level and TRACKING NBD is to set the satellite signal tracking level.

- a) Press LEFT and RIGHT arrow keys until the desired character is underscored (selected).
- b) Press UP and DOWN arrow keys to increase and decrease the selected character. Or press NUMBER keys to set the desired value directly.
- c) Press OK key to set the parameter.
- d) Press BACK key to select the parameter you wish to edit and press BACK key again to save or abort and return to the main display.

Detect & tracking level

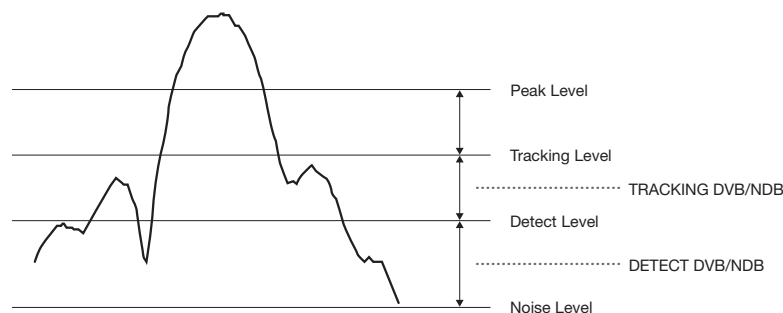

BOW & EL adjust

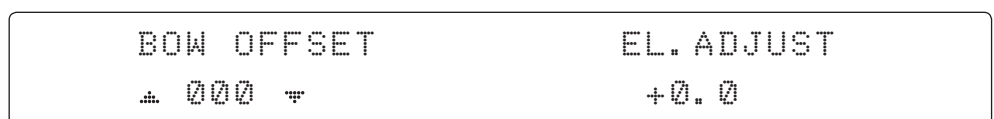

7. Set BOW OFFSET and EL. ADJUST

BOW OFFSET is to offset the angle difference between the antenna's bow and the ship's bow (Range: 0 – 360°) and EL. ADJUST is to offset the angle difference between the mechanical elevation angle and actual elevation angle (Range: ± 5°).

- a) Press LEFT and RIGHT arrow keys until the desired character is underscored (selected).
- b) Press UP and DOWN arrow keys to increase and decrease the selected character. Or press NUMBER keys to set the desired value directly.
- c) Press OK key to set the parameter.
- d) Press BACK key to select the parameter you wish to edit and press BACK key again to save or abort and return to the main display.

Select operation process



8. Set OPERATION.
Press UP and DOWN arrow keys to select OPERATION items.

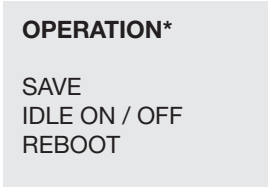

SAVE: save and execute the current settings.

The antenna is balanced at the factory. However, after disassembly for shipping, maintenance or parts replacement, antenna balance adjustment may be required. The elevation and cross-level motors have a brake mechanism integrated into them, therefore, antenna power and IDLE MODE must be ON to release the motor brakes. Balancing is achieved by adding or removing weight blocks at strategic locations to keep the antenna balanced.

IDLE MODE: Press UP and DOWN arrow keys to turn ON/ OFF IDLE MODE. The motor brakes will be released while the IDLE MODE is ON. The antenna will restart automatically if IDLE MODE is re-set from ON to OFF or BACK key is pressed to exit SETUP mode.

REBOOT ANTENNA: The antenna will restart automatically if REBOOT ANTENNA is ON.

Setup Block Zone

The blockages around an antenna may interfere with the reception of the satellite signal. Therefore, It is required to set a block zone which notifies users that antenna cannot receive satellite signal due to blockages. You can create five block zones by inputting azimuth and elevation value with ACU. When the antenna is within the block zones, the ACU works as follows.

1. "BLOCK" will be displayed on the ACU screen.
2. Tracking continues as long as the signal level is greater than the predefined threshold value. When the signal level drops below the threshold value the antenna will wait and then retarget the satellite you targeted last. The amount of time the antenna waits before entering search mode is called the "Search Wait Time" and can be adjusted in the parameters settings. The antenna will continue to retarget the satellite until the satellite is re-acquired and tracking can be resumed.
3. A transmit inhibit output from the ACU will disable/mute the modem transmission.

Up to 5 blockage or radiation hazard zones can be programmed with relative azimuth and elevation sectors.

Setup mode

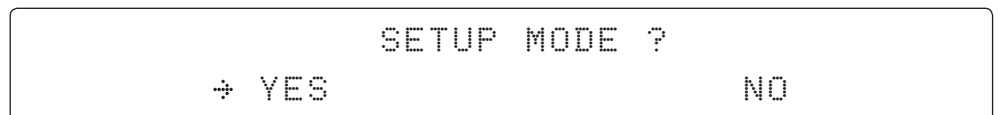

1. Press LEFT arrow key to move cursor to YES and press OK key to enter SETUP mode.

Antenna menu



2. Press OK key to enter ANTENNA menu

Block zone menu



3. Press RIGHT arrow key to move cursor to BLOCK ZONE menu and press OK key to select. Up to 5 blockage zones can be programmed.

Block zone 1



Block zone range

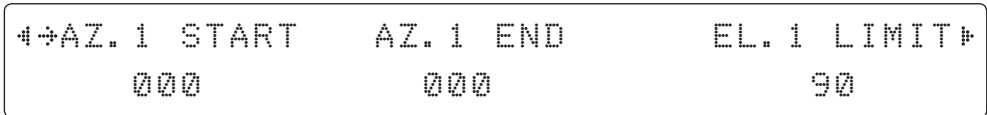

4. Set ZONE 1 BLOCK

Press UP and DOWN arrow keys to select "ON" to setup the block zone for ZONE 1. Press OK key to use ZONE 1 BLOCK and set zone 1 block range.

Press BACK key to select the parameter you wish to edit and press the BACK key again to save or abort and return to the main display.

Set the AZ.1 START, AZ.1 END and EL.1 LIMIT while ZONE 1 BLOCK is ON. This is the clockwise of the two points. AZ.1 START is where the relative azimuth starts and AZ.1 END is where the relative azimuth ends (Range: 0- 360°). EL.1 Limit is where the elevation starts (Range 0- 90°).

- a) Press LEFT and RIGHT arrow keys until the desired character is underscored (selected).
- b) Press UP and DOWN arrow keys to increase and decrease the selected character. Or press NUMBER keys to set the desired value directly.
- c) Press OK key to set the parameter.
- d) Press BACK key to select the parameter you wish to edit and press BACK key again to save or abort and return to the main display.

Block zone2 to zone 5



5. ZONE 2 to ZONE 5 BLOCK setting is same as ZONE 1 BLOCK.

Press OK key to set ZONE 2 to ZONE 5 BLOCK and set next parameter.

Save

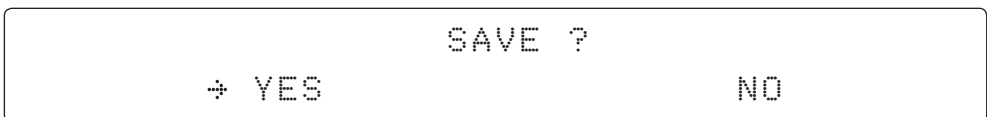

- 6. Press LEFT arrow key to move cursor to YES and press OK key to save and execute the current settings. Or press RIGHT arrow key to move cursor to NO and press OK key to abort and return to the main display.

Antenna Diagnostic Test

Refer to the diagnosis codes for the test results.

Setup mode

```

                SETUP MODE ?
          ↗ YES                NO
    
```

1. Press LEFT arrow key to move cursor to YES and press OK key to enter SETUP mode.

Antenna menu

```

    ↗+ANTENNA                +SATELLITE
      +SYSTEM                +INSTALLATION
    
```

2. Press OK key to enter ANTENNA menu.

Diagnosis menu

```

    #  +BLOCK ZONE                ↗+DIAGNOSTIC  #
    
```

3. Press arrow keys to move cursor to DIAGNOSIS menu and press OK key to select it.

Full diagnostic test

```

    DIAGNOSTIC                COMMUNICATION
    ▲ FULL TEST ▼                READY
    
```

4. Press UP and DOWN arrow keys to select a full diagnostic test or single diagnostic test and press OK key to execute the selected diagnostic test.

Menus for DIAGNOSIS are FULL TEST and CODE 101 ~ CODE 116.

Full diagnostic test result

```

    DIAGNOSTIC                FULL TESTING
    FULL TEST                #####-##-#
    
```

A full diagnostic is successfully completed as shown above.

Single diagnostic test result

```

    DIAGNOSTIC                COMMUNICATION
    CODE 101                RESULT : PASSED
    
```

A single diagnostic test is successfully completed as shown above.

Satellite Settings

Load Satellite

Setup mode

```

          SETUP MODE ?
    ↵ YES                               NO
  
```

1. Press LEFT arrow key to move cursor to YES and press OK key to enter SETUP mode.

Satellite menu

```

    +ANTENNA                ↵+SATELLITE
    +SYSTEM                  +INSTALLATION
  
```

2. Press RIGHT arrow key to move cursor to SATELLITE and press OK key to select it.

Load sat menu

```

    ↵+LOAD SAT.                +EDIT SAT.
    +ADD SAT.                  +CHECK NID
  
```

3. Press OK key to enter LOAD SAT. menu.

Load satellite

```

          LOAD SATELLITE
    ▲ [1] TELST_18 138.00E ▼
  
```

4. Press UP and DOWN arrow keys to select satellite that you wish to track. Press OK key to load the selected satellite.

Load

```

          LOAD ?
    ↵ YES                               NO
  
```

5. Press LEFT arrow key to move cursor to YES and press OK key to load the selected satellite and execute the current settings. Or, press RIGHT arrow key to move cursor to NO and press OK key to abort and return to the main display.

Edit Satellite Information

- Setup mode**
- SETUP MODE ?
 → YES NO
1. Press LEFT arrow key to move cursor to YES and press OK key to enter SETUP mode.
- Satellite menu**
- | | |
|----------|---------------|
| +ANTENNA | →+SATELLITE |
| +SYSTEM | +INSTALLATION |
2. Press RIGHT arrow key to move cursor to SATELLITE and press OK key to select it.
- Edit sat menu**
- | | |
|------------|-------------|
| +LOAD SAT. | →+EDIT SAT. |
| +ADD SAT. | +CHECK NID |
3. Press RIGHT arrow key and OK key to enter EDIT SAT. menu.
- Edit satellite**
- EDIT SATELLITE
 ▲ [1] TELST_18 138.00E ▼
4. Press UP and DOWN arrow keys to select the satellite that you wish to edit and press OK key to edit the selected satellite.
- Edit longitude & name**
- | | |
|-------------|-----------|
| LONGITUDE | EDIT NAME |
| ▲ 138.00E ▼ | TELST_18 |
5. Edit satellite orbit position, LONGITUDE and satellite NAME.
- Save**
- SAVE ?
 → YES NO
6. Press LEFT arrow key to move cursor to YES and press OK key to save and execute the current settings. Or, press RIGHT arrow key to move cursor to NO and press OK key to abort and return to the main display.

DVB verify method

DVB VERIFY	SKEW OFFSET
▲ DVB DECODE ▼	+0.0

7. Edit satellite **DVB VERIFY*** method and SKEW OFFSET.

DVB VERIFY will be only activated and applied when DVB mode for the TRACKING SIGNAL is chosen to be used. Press UP and DOWN arrow keys to select DVB VERIFY and press OK key to set the parameter.

DVB VERIFY*

AGC – use signal level for satellite tracking.
 DVB LOCK – use DVB Lock for satellite tracking.
 DVB DECODE – use DVB Decode for satellite tracking.
 DSS DECODE – use DSS Decode for satellite tracking.

Set LNB local frequency

SELECT LOCAL	TRACKING SIGNAL
▲ 11300MHz ▼	NBD

8. Set **SELECT LOCAL*** frequency and **TRACKING SIGNAL***.

Press UP and DOWN arrow keys to increase or decrease the value.
 Press OK key to set the parameter.

SELECT LOCAL*

The selectable LNB frequencies are depended on the installed LNB type.

TRACKING SIGNAL*

NBD
 DVB

Set polarity

RX POL	TX POL
▲ VERT. ▼	HORI.

9. Set RX POL and TX POL

To select the polarity for both RX (receive) and TX (transmit).
 Press UP and DOWN arrow keys to select VERTICAL or HORIZONTAL.
 Press OK key to set the parameter.

Set DVB tracking frequency

DVB FREQ.	SYMBOL	NID
↵ 11747MHz ⇄	21300KSpS	0X00AD

10. Set DVB FREQUENCY, SYMBOL RATE and NID when DVB mode of TRACKING SIGNAL is chosen to be used.

45,000 is the maximum allowed symbol rate value. NID (network ID) range is from 0 x 0000 to 0 x FFFF (hexadecimal digit).

- a) Press LEFT and RIGHT arrow keys until the desired character is underscored (selected).
- b) Press UP and DOWN arrow keys to increase or decrease the value.
Or press NUMBER keys to set the desired value directly.
- c) Press OK key to set the parameter.

Set NBD tracking frequency

NBD FREQ.	BANDWIDTH
↵ 1070.000MHz ⇄	01.000MHz

11. Set NBD IF FREQUENCY and BANDWIDTH when NBD (Narrow Band Detection) mode of TRACKING SIGNAL is chosen to be used.

- a) Press LEFT and RIGHT arrow keys until the desired character is underscored (selected).
- b) Press UP and DOWN arrow keys to increase or decrease the value.
Or press NUMBER keys to set the desired value directly.
- c) Press OK key to set the parameter.

Save

SAVE ?
⇄ YES NO

12. Press LEFT arrow key to move cursor to YES and press OK key to save and execute the current settings. Or, press RIGHT arrow key to move cursor to NO and press OK key to abort and return to the main display.

Add Satellite Information

Setup mode

```

                SETUP MODE ?
          ↗ YES                               NO
    
```

Satellite menu

```

+ANTENNA                ↗+SATELLITE
+SYSTEM                  +INSTALLATION
    
```

1. Press LEFT arrow key to move cursor to YES and press OK key to enter SETUP mode.

Add sat menu

```

+LOAD SAT.                +EDIT SAT.
↗+ADD SAT.                +CHECK NID
    
```

2. Press RIGHT arrow key to move cursor to SATELLITE and press OK key to select it.

Set longitude & name

```

↔ LONGITUDE                EDIT NAME ↔
  000.00E                SAT.00
    
```

3. Press DOWN arrow key and OK key to enter ADD SAT. menu.

DVB verify method

```

DVB VERIFY                SKEW OFFSET
↗ DVB DECODE                +00.0
    
```

4. Set satellite LONGITUDE and satellite NAME.

5. Edit the satellite **DVB VERIFY***.

DVB VERIFY will be only activated and applied when DVB mode for the TRACKING SIGNAL is chosen to be used. Press UP and DOWN arrow keys to select DVB VERIFY and press OK key to set the parameter.

DVB VERIFY*

AGC – use signal level for satellite tracking.
 DVB LOCK – use DVB Lock for satellite tracking.
 DVB DECODE – use DVB Decode for satellite tracking.
 DSS DECODE – use DSS Decode for satellite tracking.

Edit the satellite SKEW OFFSET.

- Press LEFT and RIGHT arrow keys until the desired character is underscored (selected).
- Press UP and DOWN arrow keys to increase or decrease the value.
Or press NUMBER keys to set the desired value directly.
- Press OK key to set the parameter.

Set LNB local frequency

SELECT LOCAL	TRACKING SIGNAL
▲10000MHz▼	NBD

6. **SELECT LOCAL*** to set LNB local oscillator frequency and **TRACKING SIGNAL***.
 Press UP and DOWN arrow keys to increase or decrease the value.
 Press OK key to set the parameter.

SELECT LOCAL*

The selectable LNB frequencies are depended on the installed LNB type.

TRACKING SIGNAL*

NBD
 DVB

Set polarity

RX POL	TX POL
▲ VERT. ▼	HORI.

7. Set RX POL and TX POL
 To select the polarity for both RX (receive) and TX (transmit) pol.
 Press UP and DOWN arrow keys to select VERTICAL or HORIZONTAL.
 Press OK key to set the parameter.

Set DVB tracking frequency

DVB FREQ.	SYMBOL	NID
▲00000MHz▼	00000KSp/s	0x0000

8. Set DVB FREQUENCY, SYMBOL RATE and NID when DVB mode of TRACKING SIGNAL is chosen to be used.
 45,000 is the maximum allowed symbol rate value. NID (network ID) range is from 0 x 0000 to 0 x FFFF (hexadecimal digit).
 a) Press LEFT and RIGHT arrow keys until the desired character is underscored (selected).
 b) Press UP and DOWN arrow keys to increase or decrease the value.
 Or press NUMBER keys to set the desired value directly.
 c) Press OK key to set the parameter.

Sat NBD tracking frequency

NBD FREQ.	BANDWIDTH
▲ 0000.000MHz▼	01.000MHz

9. Set NBD IF FREQUENCY and detection BANDWIDTH when NBD (Narrow band detection) mode of TRACKING SIGNAL is chosen to be used.
 a) Press LEFT and RIGHT arrow keys until the desired character is underscored (selected).
 b) Press UP and DOWN arrow keys to increase or decrease the value.
 Or press NUMBER keys to set the desired value directly.
 c) Press OK key to set the parameter.

Save

```

                SAVE ?
      ↵ YES                               NO
    
```

10. Press LEFT arrow key to move cursor to YES and press OK key to save and execute the current settings. Or, press RIGHT arrow key to move cursor to NO and press OK key to abort and return to the main display.

Check NID

Setup mode

```

                SETUP MODE ?
      ↵ YES                               NO
    
```

1. Press LEFT arrow key to move cursor to YES and press OK key to enter SETUP mode.

Satellite menu

```

+ANTENNA                ⇨+SATELLITE
+SYSTEM                  +INSTALLATION
    
```

2. Press RIGHT arrow key to move cursor to SATELLITE menu and press OK key to select it.

Check NID menu

```

+LOAD SAT.                +EDIT SAT.
+ADD SAT.                  ⇨+CHECK NID
    
```

3. Press DOWN arrow key and OK key to enter CHECK NID menu.

NID verification

```

[CHECK NID]  F: 12490  S: 27490  0X00AD
PRESS OK    RECEIVED  NID [0X0000]
    
```

4. CHECK NID is to verify the NID (Network ID) of the current tracking transponder. Press OK key to verify the NID [0 x 0000] only when " PRESS OK" is displayed which indicates the DVB Lock signal is confirmed by the antenna. However, "NO LOCK" message will be displayed if DVB Lock signal can't be confirmed.

System Settings

Set LNB Local Oscillator Frequency

Setup mode

```

                SETUP MODE ?
          ↵ YES                                NO
    
```

1. Press LEFT arrow key to move cursor to YES and press OK key to enter SETUP mode.

System menu

```

      +ANTENNA                                +SATELLITE
      ↵+SYSTEM                                +INSTALLATION
    
```

2. Press DOWN arrow key to move cursor to SYSTEM and press OK key to select it.

Set local frequency menu

```

⊠ ↵+SET LOCAL                                +SET LOCATION ⊠
      +MODEM PORT                                +MANAGEMENT
    
```

3. Press OK key to enter SET LOCAL menu to set the LNB local frequency.

LNB info

```

⊠ ↵13V + 0kHz                                18V + 0kHz ⊠
      10000MHz                                11300MHz
    
```

```

      13V + 22kHz                                18V + 22kHz
      10750MHz                                ± 09750MHz ⊠
    
```

4. Set LNB local oscillator frequency for each correspondent voltage power.
(13V +0 kHz, 18V +0 kHz, 13V +22 kHz, 18V +22 kHz)

Press BACK key and press LEFT and RIGHT arrow keys to select the parameter you wish to edit. Press OK key to edit parameter. Or, press BACK key again to return to the main display.

Save

```

                SAVE ?
          ↵ YES                                NO
    
```

5. Press LEFT arrow key to move cursor to YES and press OK key to save current settings.
Or, move cursor to NO and press OK key to abort and return to the main display.

Set Location

Setup mode

```

                SETUP MODE ?
          ↗ YES                NO
    
```

1. Press LEFT arrow key to move cursor to YES and press OK key to enter SETUP mode.

System menu

```

      +ANTENNA                +SATELLITE
    ↗++SYSTEM                +INSTALLATION
    
```

2. Press DOWN arrow key to move cursor to SYSTEM and press OK key to select it.

Set location menu

```

#  +SET LOCAL                ↗++SET LOCATION  #
    +MODEM PORT                +MANAGEMENT
    
```

3. Press RIGHT arrow key to move cursor to SET LOCATION and press OK key to select it.

Gyro type and Baud rate

```

      GYRO TYPE                BAUD RATE
      NMEA                    ↗ 4800 ↘
    
```

4. Set the ship's **GYRO TYPE*** and BAUD RATE

A search pattern 1 or 3 will be initiated according to which GYRO TYPE is selected and the existence of the gyro input. Set the BAUD RATE as 4800, 9600, 19200 or 38400 according to your device.

A search pattern 1 will be initiated automatically if the gyro input does not exist and the gyro type is selected other than GROUND TEST.

NOTE: The bow offset will not be saved automatically if Search 1 pattern is initiated. In this case, the antenna will need to retarget the desired satellite using Search 1 every time if the antenna restarts.

Gyro search type

Existence of Heading Data	Setting of Heading Device		
	No Device	NMEA / NMEA2000	Ground Test
With Heading Data	Search 1	Search 3	Search 3
Without Heading Data	Search 1	Search 1	Search 3

GYRO TYPE*

NO DEVICE
 NMEA
 NMEA2000
 GROUND TEST

Latitude & longitude

←	→	LATITUDE	LONGITUDE	→
		37.00N	126.50E	

5. Set the current LATITUDE and LONGITUDE
Press LEFT and RIGHT arrow keys until the desired character is underscored (selected).
Press UP and DOWN arrow keys to increase or decrease the value.
Or press NUMBER keys to set the desired value directly.
Press the OK key to set the parameter.

Heading

←	HEADING	→
	090.0	

6. Entry of ship's heading is not required when your system is connected to a NMEA(0813) or NMEA2000.
Ensure that the supported Gyro Type is set correctly. If the ship's gyrocompass output is other than NMEA0183 and NMEA2000, a purchase of an NMEA converter is required.

Save

	SAVE ?	
→	YES	NO

7. Press LEFT arrow key to move cursor to YES and press OK key to save current settings
Or, move cursor to NO and press OK key to abort and return to the main display.

Set Modem Port

Setup mode

```

                SETUP MODE ?
          ↵ YES                               NO
    
```

System menu

1. Press LEFT arrow key to move cursor to YES and press OK key to enter SETUP mode.

```

          +ANTENNA                          +SATELLITE
        ↵+SYSTEM                            +INSTALLATION
    
```

Modem port menu

2. Press DOWN arrow key to move cursor to SYSTEM menu and press OK key to select it.

```

#  +SET LOCAL                               +SET LOCATION #
  ↵+MODEM PORT                             +MANAGEMENT
    
```

Set Mediator & modem type

3. Press DOWN arrow keys to move cursor to MODEM PORT menu and press OK key to select it.

```

          USE MEDIATOR                       MODEM TYPE
          ⚡   NO   ⚡                         IDIRECT-I/O
    
```

4. USE MEDIATOR when the antenna is connected to the Intellian Dual VSAT Mediator.

NOTE: USE MEDIATOR must be disabled if there is no MEDIATOR connected to the ACU. Improper setting of this parameter will cause your ACU's modem interface to not work correctly.

MODEM TYPE* is to select a proper data communication port and protocol on the ACU to interface with the satellite modem. The settings related to the modem interface will be set automatically once the modem type is selected. Select "USER SETTING" if a desired modem type is not available in the option.

The options on the next page will be displayed and required to be set if "USER SETTING" is selected.

MODEM TYPE*	
USER SETTING	SATLINK-VACP
IDIRECT-I/O	ELEKTRIKOM-AMIP
IDIRECT-AMIP	GILAT-SE-II
COMTECH-I/O	IPSTAR-SOTM
COMTECH-ROSS	INMARSAT-G5
HUGHES	NEWTEC-AMIP
SATLINK-SEIRAL	

Set modem protocol



5. **MODEM PORT*** is to select a proper data communication port on the ACU to interface with the modem. Press UP and DOWN arrow keys to select MODEM PORT and press OK key to set the parameter.

PROTOCOL* is to select a proper communication protocol on the ACU to interface with the modem.

- MODEM PORT***
 ETHERNET
 RS232
 RS422

- PROTOCOL***
I/O CONSOLE: is a protocol for interchanging of information (GPS Out, TX mute, and modem lock) between the ACU (through Console port) and a modem.
- OPEN AMIP:** is an ASCII based protocol developed by iDirect for interchanging of information between the ACU and a modem. OpenAMIP is not intended for any purpose except to allow the ACU and a modem to perform synchronized automatic beam switching (ABS).
- SERIAL GPS:** is a protocol for sending GPS Out information from the ACU (through RS232/422 port) to a modem.
- ROSS:** ROSS Open Antenna Management (ROAM) protocol is developed by Comtech EF Data Cooperation to offer common management interface for Comtech EF Data's Roaming Oceanic Satellite Server (ROSS) and ACU.
- VACP:** is the interface between the SatLink mobile VSAT IDU and the Intellian antenna controllers for Intellian mobile antennas.
- ELEKTRIKOM AMIP:** is the interface using extended Open AMIP including the console port (modem lock) between the elektrikom ROAM-PC and the Intellian controller.
- GILAT:** is a protocol that generates between the Gilat SkyEdge modem and the Intellian antenna controllers two-channel interfacing based on the NMEA 0183 data protocol. The interfacing occurs via RS232 serial port at 9600-N-8-1 baud.
- SOTM:** is a protocol interface between the ACU and the IPSTAR modem's beam switching controller to perform automatic beam switching (ABS).

Use TX mute

```

GPS OUT SENTENCE      USE TX MUTE
  ▲                ▼
  GPGLL              YES
    
```

6. **GPS OUT SENTENCE*** is to select the GPS OUT SENTENCE type. USE TX MUTE is to select whether or not to USE TX MUTE function from the satellite modem. A transmit inhibit output from the ACU will disable/mute the modem transmit via a voltage whenever the antenna is blocked, searching, or pointed 0.5 degrees off from the peak satellite position. Press UP and DOWN arrow keys to select GPS OUT SENTENCE and press OK key to set the parameter.

```

GPS OUT SENTENCE*
GPGLL
GPGGA
SIMPLE GPGGA
    
```

Use EXT.LOCK

```

USE EXT. LOCK          EXT. LOCK ACTIVE
  ▲                ▼
  YES                  LOW
    
```

7. USE EXT. LOCK and EXT. LOCK ACTIVE will only be activated when PROTOCOL is set as I/O CONSOLE. USE EXT. LOCK is to select whether or not to use external lock signal from the satellite modem.

EXT. LOCK ACTIVE refers to a modem lock output from the modem providing a logic input through a 5 V (HIGH) or 0 V (LOW) current to the ACU to identify when it is on the correct satellite. Press UP and DOWN arrow keys to select EXT. LOCK ACTIVE and press OK key to set the parameter.

TX mute activation

```

TX MUTE ACTIVE
  ▲                ▼
  LOW
    
```

8. TX MUTE ACTIVE item will only be activated when PROTOCOL is set as I/O CONSOLE. TX MUTE ACTIVE is a transmit inhibit output from the ACU to disable/mute the modem transmit through a 5 V (HIGH) or 0 V (LOW) current whenever the antenna is blocked, searching, or is pointed 0.5° off from the peak satellite position. Press UP and DOWN arrow keys to select TX MUTE ACTIVE and press OK key to set the parameter.

Save

```

                                SAVE ?
  → YES                            NO
    
```

9. Press LEFT arrow key to move cursor to YES and press OK key to save current settings. Or, move cursor to NO and press OK key to abort and return to the main display.

System Management

Setup mode

SETUP MODE ?
 → YES NO

1. Press LEFT arrow key to move cursor to YES and press OK key to enter SETUP mode.

System menu

+ANTENNA +SATELLITE
 →+SYSTEM +INSTALLATION

2. Press DOWN arrow key to move cursor to SYSTEM menu and press OK key to select it.

Backup and restore menu

← +SET LOCAL +SET LOCATION →
 +MODEM PORT →+MANAGEMENT

3. Press arrow keys to move cursor to MANAGEMENT menu and press OK key to select it.

Select process type

SELECT PROCESS TYPE
← BACKUP USER DATA →

4. Press UP and DOWN arrow keys to **SELECT PROCESS TYPE***
 Press OK key to set the parameter and the processing message will be displayed.

Processing

- SELECT PROCESS TYPE***
- BACKUP USER DATA:** To backup the antenna settings set by user to the ACU.
 - RESTORE USER DATA:** To restore the antenna by using the backup user data stored from the ACU.
 - DEFAULT ACU-REMOTE P/W:** To change the web server module's password to default.
 - UPGRADE FROM USB:** To upgrade the system by using firmware files (FWP) from a specified folder in a USB flash drive.
 - COPY LOG TO USB:** to copy the antenna log data from the system to a USB flash drive.
 - BACKUP TO USB:** To backup the antenna settings set by user to a USB flash drive.
 - RESTORE FROM USB:** To restore the antenna by using the backup user data from a USB flash drive.
 - UPGRADE ACU-REMOTE:** To upgrade the system using firmware files (FWP) from a specified folder in a USB flash drive.

NOTE: UPGRADE FROM USB, COPY LOG TO USB, BACKUP TO USB, RESTORE FROM USB and UPGRADE ACU-REMOTE options are displayed only if the USB flash drive is plugged into the USB port.

Key Lock / Password Management

Setup mode

```

                SETUP MODE ?
            ↗ YES                               NO
    
```

1. Press LEFT arrow key to move cursor to YES and press OK key to enter SETUP mode.

System menu

```

        +ANTENNA                +SATELLITE
    ↗++SYSTEM                +INSTALLATION
    
```

2. Press DOWN arrow key to move cursor to SYSTEM menu and press OK key to select it.

Key lock menu

```

#  ↗++KEY LOCK                +INTELLIAN DEVICE  #
    
```

3. Press arrow keys to move cursor to KEY LOCK menu and press OK key to select it.

Set key lock and password

```

        KEY LOCK                UNLOCK P/W
    #  ON                        1590
    
```

4. Press UP and DOWN arrow keys to choose whether or not to use key pad lock when entering the SETUP mode or saving the satellite information. Setup the password for entering the key pad lock. The factory default is 1590.

Check key lock activation

```

# TRACKING 138.0E TELST_18 SIG: 301#VL #
 *AZ: ---. - ( 202.7) EL: 48.3 SK: -72.0 Fm
    
```

When KEY LOCK function is activated, the " # " mark is displayed.

Introduction

Requirements

Software Installation

PC to ACU Communication Setup

Starting Aptus®

Establish a data communication

AutoUpdate

Toolbar Menus

System Property Status Dashboard

Work View Tabs

1. Antenna – Basic Info.
2. Antenna – Advanced Info.
3. Satellite
4. Graph View
5. Monitor
6. Diagnostic / Modem
7. GUI
8. Work View Functions

Introduction

Intellian's Antenna PC Controller Software, Aptus® is a next-generation graphically based antenna remote control software. The Aptus® allows users to easily and conveniently set up the antenna by using a personal computer.

The minimum PC hardware and software requirements to install and run Aptus® are as below.

Requirements

Hardware

Hardware	Requirements
CPU	Intel® Pentium® 4 or higher
Memory	512MB or higher
Video Card	DirectX9.0 or higher supported
	H/W acceleration supported
	Video Memory 128MB or higher
HDD	1GB or higher

Operating System and Software

Software	Requirements
Operating System	Windows XP SP or higher
Framework	Microsoft.Net Framework 3.5 Service Pack 1 or higher

Software Installation

Double click the 'Aptus Setup.exe' icon  to install Aptus® directly onto your computer/ laptop. The InstallShield Wizard will guide you through the program setup process. The installation routine provides an icon on the desktop.

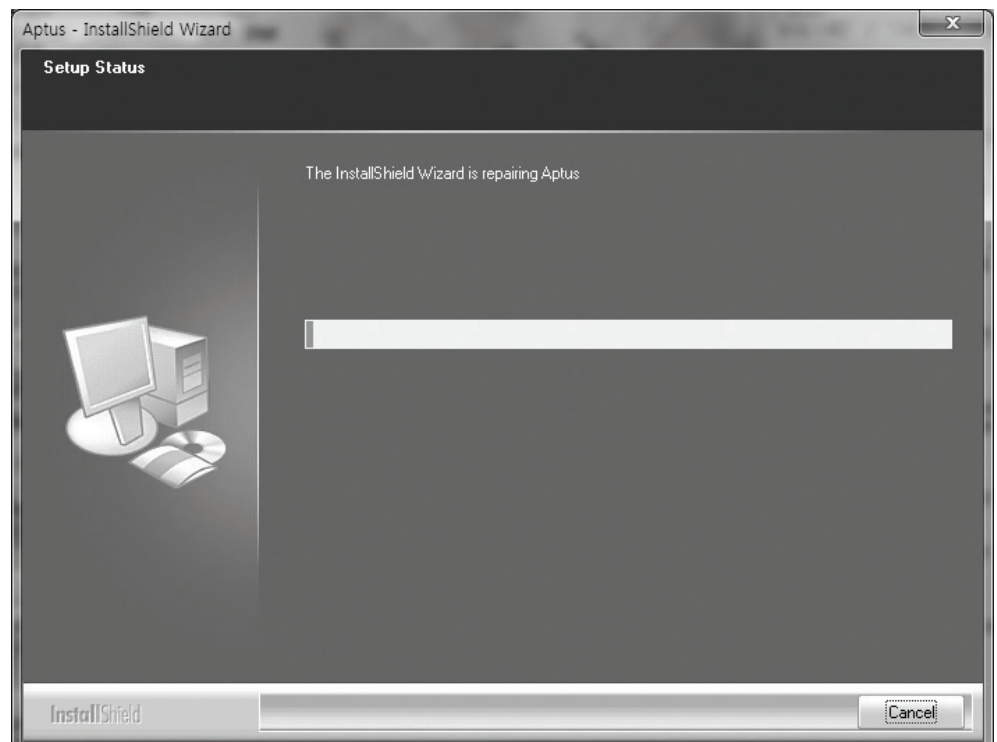

Click the icon to start the software. In addition, Intellian also provides patch files for software upgrade.

PC to ACU Communication Setup

Starting Aptus®

Double-click the Aptus® desktop icon to open a Communication Window to establish the data communication between your PC and the ACU. Select which method to connect to your ACU, either through the Serial Port Communication or the Network Communication (TCP/IP).

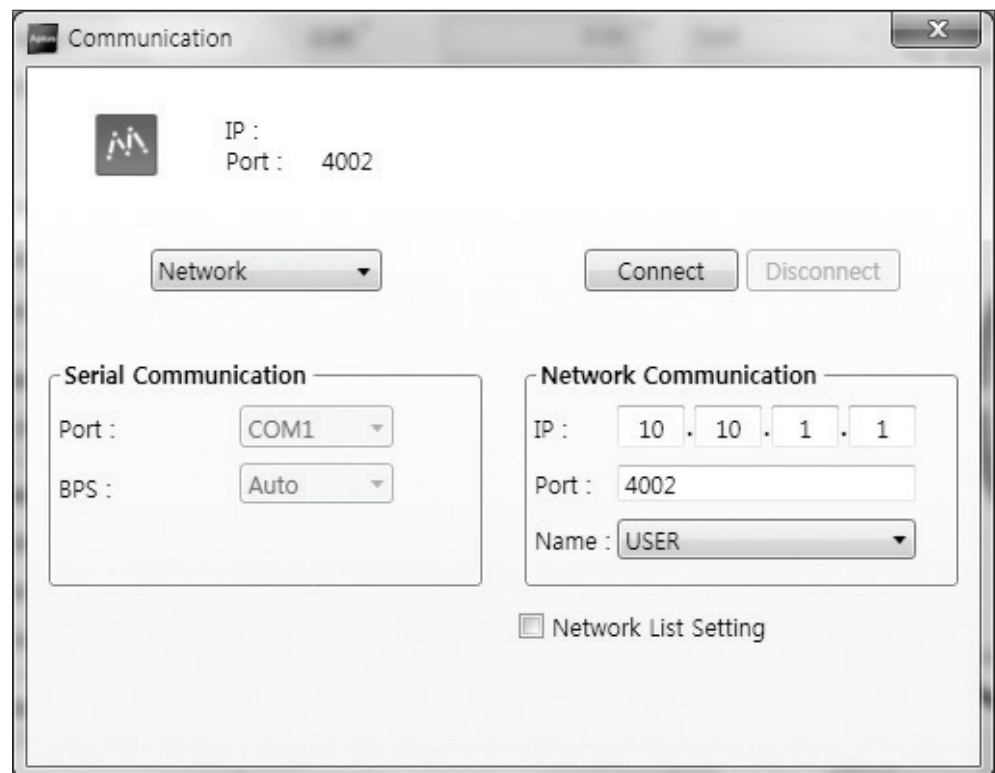

Establish a data communication

Access ACU through Serial Communication

1. Connect a 9 pin Serial cable between the PC INTERFACE connector on the ACU and the 9 pin Serial port on the PC. (Or you can use a USB cable to setup Serial connection between a PC and the USB port on the ACU.)
2. Select Serial at communication type combo-box.
3. The baud rate of the ACU is 57600.
4. Select a COM port which is not occupied by other devices.
5. Click the Connect button.

Access ACU through Network Communication (TCP/IP)

1. Turn off the wireless connection while using this method.
2. Connect your PC to the Management Port.
3. Select Network at communication type combo-box.
4. Enter in the ACU's IP address (Factory default: 192.168.2.1)
5. Enter in the ACU's port number (Factory default: 4002)
6. Click the Connect button then the Authentication window will appear.
7. Login by using the username and password below:
 - Username: intellian (Factory default)
 - Password: 12345678 (Factory default)

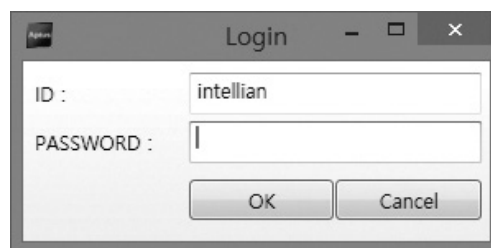

The screenshot shows a 'Login' dialog box with the following fields and buttons:

- ID :
- PASSWORD :
- OK button
- Cancel button

NOTE: If the remote access PC is located in the same network group with the ACU, the ACU can be accessed through the internal IP address. But, if the remote access PC is located outside of the network group, the ACU's IP address should be changed to the IP address assigned by the network service provider.



WARNING:

- Do not plug a USB to the ACU while TCP/IP communication is in use. Doing so will disable current PC Software Control because the USB connection has higher priority than TCP/IP connection.
- The amount of data will increase rapidly if Network Communication is in use. Intellian recommends using Aptus Web.

AutoUpdate

Intellian Aptus® checks and notifies the latest version when it is started to maintain up to date software version by its AutoUpdate function.

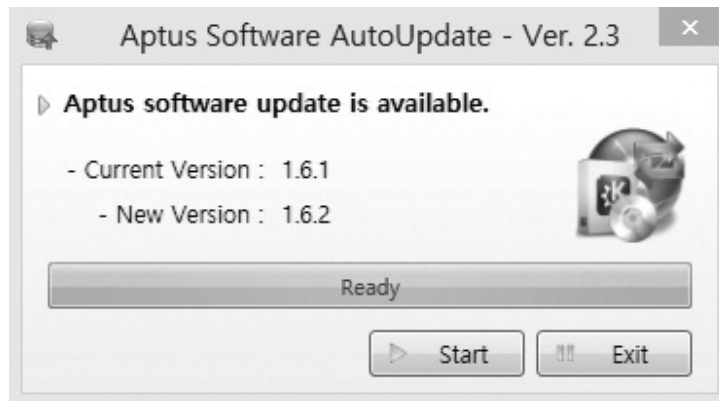

1. When Aptus® is started, it automatically checks the latest software version from the server and runs AutoUpdate which will display the current software version and if a new version is available.
2. When a new software version is available, click the "Start" button and "File downloading..." message will be displayed while the files are downloaded from the server. When file downloading is finished, "installing..." message is displayed and Aptus patch runs and the installation starts by InstallShield.

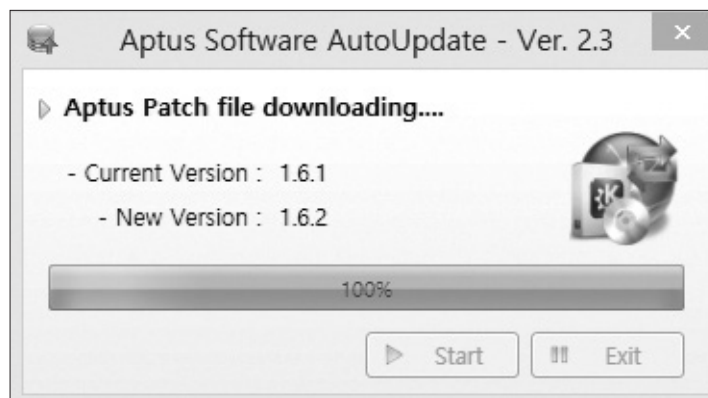

3. Click the "Finish" button when InstallShield installation is finished, then "Run the Aptus" message is displayed and Aptus runs and AutoUpdate is automatically finished.

Toolbar Menus

The toolbar menus at the top of the screen display command buttons of the most commonly used functions of the Aptus®. The toolbar menu consists of 6 main menus; Quick (for quick launch of functions), File (for file backup, restoring and loading), View, Connection, Util, and Setting & Help.

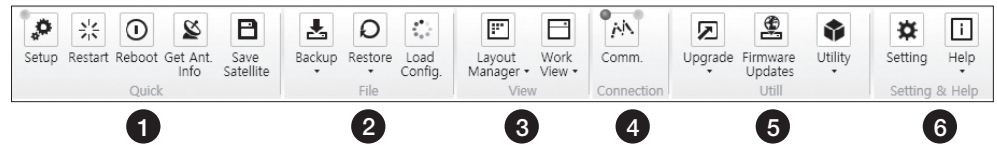



① Quick

-  **Setup:** enters Setup mode.

-  **Restart:** exits Setup mode and restarts the antenna.

-  **Reboot:** reboots the antenna.

-  **Get Ant. Info:** obtains the information stored in the antenna.

-  **Save Satellite:** saves the current bow offset only if the antenna is tracking onto the satellite. The satellite acquisition time can be reduced significantly after the antenna is restarted.

② File

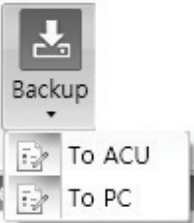
-  **Backup:** backups the antenna information to ACU or PC.
 - Select 'To ACU' to backup the antenna information to ACU. The backup file (file format: *.ibf) will be stored on the ACU.
 - Select 'To PC' to backup the antenna information to a PC. The backup files (file format: *.rpt and *.ibf) will be generated on the PC.

NOTE: Both *.rpt and *.ibf files contain antenna information. However, while *.ibf file can be used for restoring antenna information, *.rpt file is stored as plain-text for viewing purpose only. Users can open the *.rpt using text editors such as notepad software.

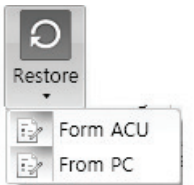
-  **Restore:** restores the antenna by using the stored information in ACU or PC.
 - Select 'From ACU' to restore the antenna by using the stored information in ACU.
 - Select 'From PC' to restore the antenna by using the stored information in PC (file format: *.ibf).

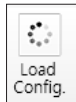

Load Config.: loads the antenna configuration file (file format: *.cfg).
 The configuration file includes the antenna control parameters which are pre-loaded at the factory and should only be changed by an authorized service technician. Improper setting of these parameters will cause your system to perform improperly.

③ View

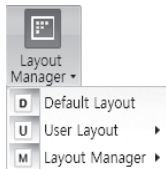

- **Default Layout:** returns the current layout to the default layout.

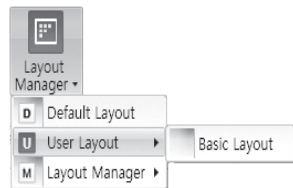

- **User Layout:** displays the layout list that the user has previously stored by using Layout Manager. If you select a layout in this list, the selected layout will be constructed in Work View screen. The 'Basic layout' is provided by default.

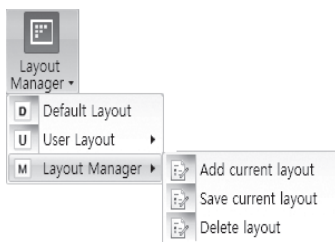

- **Layout Manager:** provides the user with add, delete, and save functionalities in order to manage the user's layouts.
 - Selecting 'Add current layout' opens a pop up window. Type in a desired name of current layout and click Add, then the new name of the current layout will be saved to the list under User Layout menu.
 - When changes are made to the current layout, select 'Save current layout' option. The current layout will be saved with changes.
 - To remove a layout, select 'Delete layout' option. Select a desired layout to remove on the pop up window, then click 'Delete'. Close the window by clicking on 'Close'. The selected layout is removed from the User Layout list.

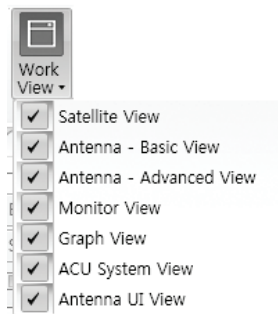

- **Work View:** displays a list of seven pre-constructed Work View Tabs (Satellite View, Antenna Basic View, Antenna Advanced View, Monitor View, Graph View, ACU System View, and Antenna UI View) and also provides the Activate / Close functionalities for each view tab. Activate the work view tab by ticking the checkbox next to it.

④ Connection

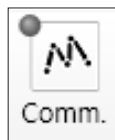

At any time, data communication channel can be re-established between Serial and Network connection. Selecting Comm. Button will display the Communication Window to connect to the ACU via Serial or Network communication.

⑤ Util



- **Firmware Uploader:** Upload the firmware of antenna and ACU. Ensure the USB cable is connected between the 'USB port' on the PC to the 'PC port' on the ACU.
- **iARM Upgrade:** Upgrade the firmware of iARM module.



Firmware Updates: provides the user with the latest firmware version and updates firmware by simple steps.

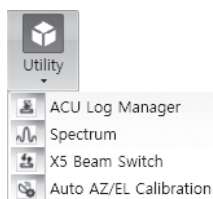

- **ACU Log Manager:** displays the antenna log data in calendar view which is downloadable directly to a desired path.
- **Spectrum:** displays current spectrum graph and allows to set spectrum data view options.
- **X5 Beam Switch:** Switch the iDirect X5 Beams and receive the beam list using the connected LAN cable to the iDirect X5 modem directly.
- **Auto AZ/EL Calibration:** Calibrates the Bow / EL Offset automatically during initialization. Calibrate the LNB pol angle when the control board, po-tentiometer or belt is replaced.

⑥ Setting & Help

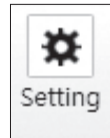

- **Auto Update:** When Aptus PC has started, you can turn auto update on or off. If you click the auto update check button, Aptus PC will check and update, if there is a new version available for download on the server.
- **Network Communication:** Set up the timeout to display the message box which appears when the TCP is not connected to the antenna.

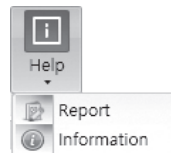

- **Report:** provides e-mail contact to Intellian technical support team to let the user report problems at any time.
- **Information:** displays the information of current Aptus® software version.

System Property Status Dashboard

The property status dashboard on the left pane of the screen provides the antenna status, diagnostic error report, the availability of TX transmission, signal level, GPS, heading status, time status, date status, voltage, software information and product information to be monitored quickly.

The dashboard consists of eight numbered sections:

- Antenna Status: Tracking**
 - Buttons: Initialize → Search → Tracking
- Diagnostic Error Report**
 - Checkbox:
- TX Mute**
 - Radio buttons: Enable Mode (selected), Blockage, Pointing, Modem Lock, LNB Rotate
- Signal Level DVB 142**
 - Progress bar: 142
 - Local Frequency: 11300 MHz
- GPS**
 - Coordinates: 127.05 E 37.07 N
 - Heading: 0.00
 - Time: 08:09:13 (UTC)
 - Date: 2016-11-02
- Voltage**
 - Antenna: 24.4V
 - ACU: 27.3V
- Software Information**
 - Ant. PCU: V 9.00
 - Ant. Stabilizer: V 9.00
 - ACU Main: V 9.00
 - Lib Version: V 1.02
 - Web Server: V 9.00
- Product Information**
 - System Model: V65
 - Ant. Name: V4-650-CJW
 - Ant. Serial: V0616100004
 - ACU Name: VP-T529
 - ACU Serial: PVP16107924
 - System Pol: Cross
 - System Band: KU Band

- ① Antenna Status: Displays the status of the current mode of the antenna.
- **Search 1:** A Search 1 pattern will automatically be initiated when the ship's heading input does not exist or if it fails. The search cycle will repeat until the antenna receives the lock signal from the modem or until the DVB transponder of the target satellite is decoded by the antenna.
 - **Search 2:** Search 2 is reserved for future use.

- **Search 3:** Search 3 pattern will automatically be initiated when AGC (DVB mode is in use) or SIG/dB (NBD mode is in use) falls below the current tracking level threshold value. Once the desired signal is found and above the predefined tracking threshold, the ACU will enter to tracking mode.
- **Tracking:** Antenna is tracking the target satellite.
- **Initialize:** Antenna or ACU is initializing.
- **Setup:** Antenna is in SETUP mode.

② Diagnostic Error Report

The square button next to the Diagnostic Error Report turns red when the system receives an error. Click the button to see a Diagnostic Report.

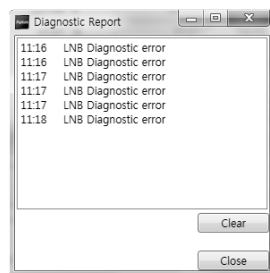

③ TX Mute

Displays the status of TX transmit. If the circle next to the TX Mute shows "Blue", it means the antenna TX function is enabled. If the circle shows "Red", it means the antenna TX function is disabled. The TX function will be enabled only if all five factors (Enable Mode, Blockage, Pointing, Modem Lock, and LNB Rotate) listed below show a "Blue" circle. However, if the "Use TX Mute" function in the 'ACU System' Work Tab is disabled, the TX function will be enabled regardless the above factors.

- **Enable Mode:** displays whether or not the antenna is transmitting.
- **Blockage:** displays whether or not the antenna is pointing in a predefined block zone(s). If the antenna is pointing in the block zone, the circle next to the Blockage will show "Gray". If the antenna pointed outside the block zone, the circle next to the Blockage will show "Blue".
- **Pointing:** displays whether or not the antenna is pointing to the target satellite. If the antenna is not pointing to the target satellite, the circle next to the Pointing will show "Gray". If the antenna is pointing to the target satellite, the circle next to the Pointing will show "Blue".

- **Modem Lock:** displays whether or not the modem is locked by receiving a confirmation signal from the satellite modem. If the modem is not locked, the circle next to the Modem Lock will show "Gray". If the modem is locked, the circle next to the Modem Lock will show "Blue".

NOTE: If the Modem Lock shows "Gray", check the cable connection between the antenna system and the satellite modem as well as settings on the modem.

- **LNB Rotate:** displays whether or not the LNB is rotating. If the LNB is rotating, the circle next to the LNB Rotate will show "Gray". If the LNB is not rotating, the circle next to the LNB Rotate will show "Blue".

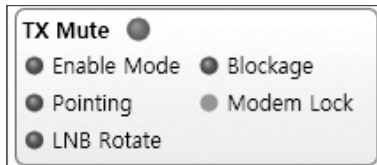

④ Signal Level

Shows "DVB" when DVB mode of tracking signal is in use and "NBD" when NBD mode of tracking signal is in use. The "Red" line indicates the signal "Detect Level Threshold" and the "Orange" line indicates the signal "Tracking Level Threshold". If the signal level is higher than the tracking level threshold, the signal level bar will display "Blue" color. If the signal level is lower than the tracking level threshold, the signal level bar will display "Orange" color and the antenna will stay in searching mode.

NOTE: If the signal level is not higher than the tracking threshold, decrease the detect and tracking level.

⑤ GPS and Heading

Displays the current GPS location from the Antenna and Ship's heading information. The status light flashes green if the system receives a correct input of the GPS and Ship's heading.

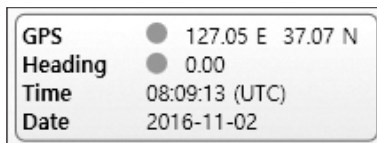

⑥ Voltage: Displays the antenna and the ACU voltage information.

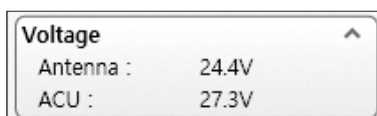

- ⑦ Software Information: Displays the antenna and the ACU firmware versions, and the library version.

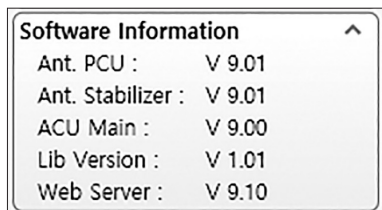

- ⑧ Product Information: Displays the antenna and ACU serial numbers, antenna model and ACU model.

Work View Tabs

Aptus® provides seven Work View Tabs (Antenna Basic View, Antenna Advanced View, Satellite View, Graph View, Monitor View, Diagnostic/Modem View, and GUI View) to manage the Antenna and the Satellite configuration.

How to modify the settings on Work View;



1. Enter the Setup mode by clicking Setup icon.

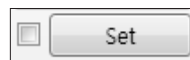

2. Tick the checkbox next to the "Set" button to modify the settings.
3. Enter the desired value then press the Set button to save the settings.

1. Antenna – Basic Info.

This view tab provides information on the Antenna's Current GPS location, Heading Device, Bow Information, Skew Information, and the Antenna's Angle. This view tab uses the Antenna's AZ and EL information as well as the Ship's Heading information in order to provide a dynamic graphic user interface (UI).

The screenshot displays the 'Antenna - Basic Info' tab with the following data and controls:

- GPS:** Longitude: 127.06° E (input: 127.06, dropdown: East); Latitude: 37.24° N (input: 37.24, dropdown: North). Includes a 'Set' button.
- Heading:** Heading: 0.00° (input: 0.00, dropdown: Fixed); Heading Device: Fixed. Includes 'Set' buttons.
- Bow Information:** Current Bow Offset: 14° (input: 14). Includes a 'Set' button.
- Skew:** Satellite Skew Offset: 0.00°; Mechanical Skew Offset: 0.00° (radio button selected); Consolidated Skew Offset: 0.00°. Includes 'Pol Sensor Calibration' and 'Reset Mechanical Skew Offset' buttons.
- Antenna Angle:** AZ Relative: 126.85°; AZ Absolute: 126.85° / 197.97°; EL: 18.47° / 45.30°; POL: -75.70° / -75.87°. Includes directional arrow buttons.
- Compass:** A circular compass showing North (N), South (S), East (E), and West (W). A satellite icon is positioned at 197.97°.
- Antenna Diagram:** A diagram showing the antenna's elevation angle (EL) as 18.47° and 45.30°.

- **GPS:** displays and sets current antenna's GPS.

- **Heading:** displays and sets current ship's heading information.
 - Heading Device: None / NMEA/ NMEA 2000/Ground Test. The baud rate (4800/ 9600/ 19200/ 38400) must be set if NMEA is selected.

- **Bow Information:** displays and sets current antenna's bow.

- **Skew:** displays current antenna's skew and skew offset.
 - Pol Sensor Calibration: calibrates the sensor (potentiometer).
 - Reset Mechanical Skew Offset: the mechanical skew offset is preset in the factory with a default value (0, 1, or 2) depending on the assembly status. Resetting of the mechanical skew offset may be required when the satellite skew offset is unknown (Consolidated Skew Offset = satellite skew offset + mechanical skew offset). Due to each satellite having its own skew offset, Intellian recommends you check with your service provider or satellite operator to get the satellite skew offset value and input it in Satellite Work Tab rather than resetting the mechanical skew offset directly.

- **Antenna Angle:** displays and sets current antenna's absolute and relative AZ (azimuth) position, EL (elevation) position and LNB Pol angle. You can move antenna azimuth and elevation position and LNB Pol angle by using the arrows or inputting a value to find the desired satellite manually.

2. Antenna – Advanced Info.

This view provides information on the Tilt Sensor Bias, Rate Sensor Bias, Conical Range, EL Adjust, Search Parameter, Threshold Setting and Blockage.

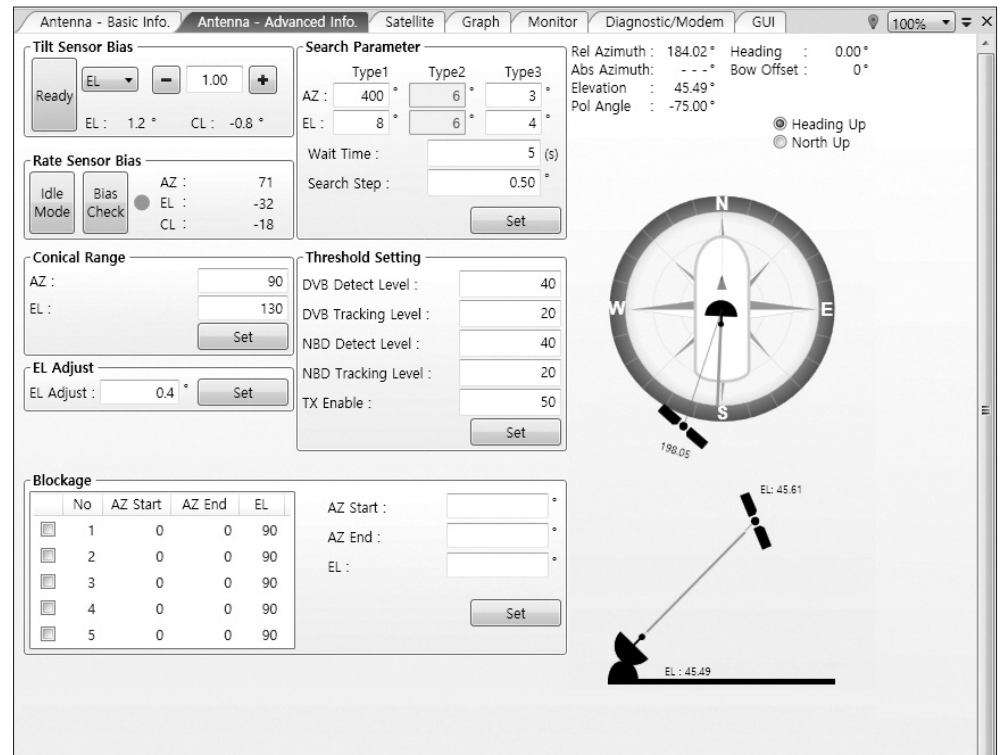

- **Tilt Sensor Bias:** This maintains the elevation and the cross level axes in order to keep the pedestal parallel to the horizon. Adjust the two solid-state tilt sensors to provide absolute cross-level tilt of the antenna and elevation feedback to eliminate long-term pointing drift (error). Tilt bias must be adjusted when the antenna control board or sensor box is replaced. If the bubble on the button level located on the sensor box is not centered, follow the steps below to adjust the tilt sensor bias.

- Step 1. Enter Setup mode and press the "Ready" button to bring the elevation and cross-level to 0.
- Step 2. Select "EL" from the drop down list and press Up and Down arrow keys to adjust the bubble until it is located in the center ring of the button level.
- Step 3. Select "CL" from the drop down list and press Up and Down arrow keys to adjust the bubble until it is located in the center ring of the button level.
- Step 4. Press the "Restart" icon to restart the antenna.



- **Rate Sensor:** is used to calibrate the DC voltage output from the three rate sensors (azimuth, elevation, and cross-level). These are used to sense antenna motion that corresponds to the ship's motion (roll, pitch, and yaw) for stabilizing the pedestal. The DC voltage output from each of the rate sensors may vary by an amount which is directly proportional to the direction and rate of motion induced on it.

Before calibrating the rate sensors located in the Sensor box, make sure that the antenna is placed on a rigid and flat platform. During the calibration process, any motion of the antenna should be avoided as it can affect the antenna's performance. Proceed with the following steps to perform the calibration.

- Step 1. Enter Setup mode
 - Step 2. Press the "Idle Mode" button to release the elevation and cross level motor brakes while the antenna is in Setup mode.
 - Step 3. Check whether or not the bubble is located at the center of the button level. If not, move it to the center by following the previous instruction of Tilt Sensor Bias adjustment.
 - Step 4. Press the "Bias Check" button to calibrate the rate sensor. A blue circle will be displayed next to the Bias Check button if the calibration is completed. A red circle will be displayed if calibration failed. A green circle will be displayed during the calibration process.
-
- **Conical Range:** The relative force of the motors controlling azimuth and elevation. Set the conical range while the antenna is in tracking mode.

 - **EL Adjust:** The elevation adjustment is to offset the angle difference between the mechanical elevation angle and actual elevation angle. If this value is not properly adjusted, the antenna may take longer time for satellite search or tracking.

 - **Search Parameter:**
 - Wait time: set the time-out for automatic initiation of a search after the signal level drops below the pre-defined threshold value.
 - Search Step: set incremental step size.
 - Type 1 & Type 3 (Search 1 & 3) Range: set Search 1 & 3 search range. Search 3 is conducted in a two-axis pattern consisting of alternate movements in azimuth and elevation as it forms an expanding square.
 - Type 2 (Search 2) Range: is reserved for future use.

- **Block Zone:** Displays current block zones by azimuth and elevation sectors. Up to 5 block zones can be programmed. Once the block zone is created, a blue shaded area will be displayed in the Antenna UI view on the right.

- **Threshold Settings**
 - DVB Detect Level: displays and sets signal detection threshold level when DVB tracking mode is in use.
 - DVB Tracking Level: displays and sets signal tracking threshold level when DVB tracking mode is in use.
 - NBD Detect Level: displays and sets signal detection threshold level when NBD tracking mode is in use.
 - NBD Tracking Level: displays and sets signal tracking threshold level when NBD tracking mode is in use.
 - TX Enable Threshold: displays and sets TX enable threshold.

3. Satellite

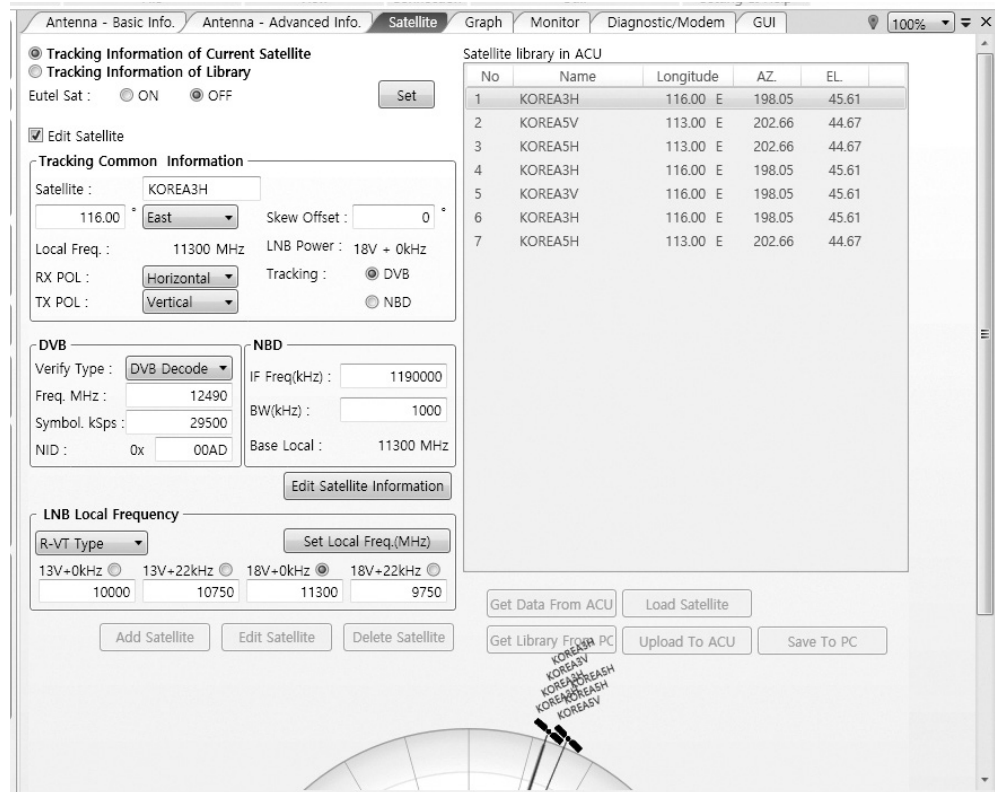

This view provides information on the Satellite's Information, Tracking Common Information, DVB and NBD Tracking Transponder, LNB Local Frequency, and Satellite Library. This view shows a graphical UI of the current satellite that the antenna is pointing at and the satellites that are located in an 180° arc on the horizon with reference to the current position.

NOTE: Based on the satellite EIRP footprint and the size of the antenna, you may not be able to track all the satellites visible in 180° arc.

- **Tracking Information of Current Satellite:** displays the current satellite's name, longitude position, and satellite skew of the satellite in the library.
- **Tracking Common Information:** displays the current LNB local oscillator frequency that is in use and the corresponding voltage supplied. Selects the tracking mode (DVB / NBD) to be used and sets polarization (Horizontal / Vertical) for the RX pol and the TX pol.

- **DVB/NBD:** sets tracking transponder information for either DVB tracking mode (Verification Type, Frequency, Symbol rate, and NID) or NBD tracking mode (Frequency and bandwidth).

NOTE: DVB and NBD parameter settings should only be changed by an authorized service technician. Improper setting of these parameters will render your system inoperable. Consult Intellian for changing antenna parameters.

- **LNB Local Frequency:** Displays or sets LNB local frequency and its corresponding LNB voltage supplied. You may select pre-programmed LNB LO settings from the drop down list. This procedure is same for both the Intellian Global VSAT PLL LNB and any other LNB.
- **Tracking Information of Library:** Selecting this option enables "Add Satellite", "Edit Satellite" and "Delete Satellite" buttons as shown at bottom of window.
 - **Eutelsat:** Select 'ON' when the antenna is tracking an Eutelsat satellite. With this option enabled, a defined skew angle for each Eutelsat satellite is automatically applied without allowing a manual modification to the skew offset value.
 - **Get Library From PC:** opens the satellite library file (File format:*.ilf) from the PC.
 - **Get Data From ACU:** obtains the satellite information from the ACU.
 - **Load Satellite:** uploads the satellite information to the ACU.
 - **Upload to ACU:** uploads the satellite library to ACU.
 - **Edit Satellite:** edits the satellite information of the selected satellite.
 - **Add Satellite:** adds the satellite information as defined in the current settings.
 - **Delete Satellite:** deletes the selected satellite from the library.
 - **Save to PC:** saves the current library settings to PC.

NOTE: It is required to click the "Save to PC" button after "Edit Satellite", "Add Satellite", or "Delete Satellite" button is clicked.

4. Graph View

This view provides information on Signal, Elevation (EL), Absolute AZ (Azimuth), Relative AZ, Heading, AZ and EL in Single or Multi graph formats.

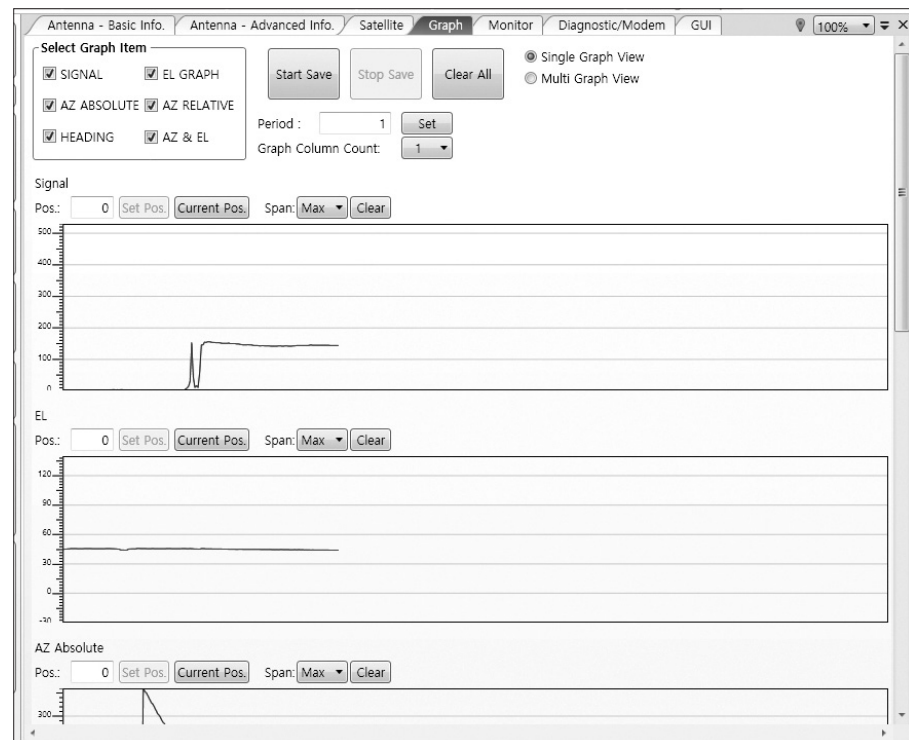

- **Select Graph Item:** shows the graphs of only the checked item(s) in a Single or Multi Graph View.
- **Single Graph View:** shows Graph Views per each single Graph Item selected in 'Select Graph Item'.
- **Multi Graph View:** shows one large integrated Graph View of multiple Graph Items selected in 'Select Graph Item'.
- **Start/Stop Save:** the chosen item is saved in the data log. The data log which stores the information displayed in the graphs can be later used for a service technician to find out a cause of any possible problem with the antenna.
- **Clear All:** clears everything drawn on the Graph View window.
- **Set Pos.:** sets the current position as center value of each Graph Item.
- **Current Pos.:** moves to the location according to values of each Graph Item.
- **Span:** sets the Display Range(s) of each corresponding Graph Item.
- **Period:** displays and sets the signal sampling rate.
- **Graph Column Count:** makes all Graph Views show in either one or two-column format.

5. Monitor

This view provides a UI which can monitor all data that has been received from the ACU.

The screenshot shows the 'Monitor' tab of the software interface. It features a table with columns for Time, Message, Signal, AZ_ABS, AZ_REL, EL, Heading, and GPS. Below the table are several control panels: 'Tracking' (ON/OFF), 'Rate Sensor Bias' (AZ, EL, CL values), 'Tilt Sensor Bias' (EL and CL tilt values), 'FSK' (Get Info), 'Show Param', 'Check NID', 'Save Debug (Start)', 'Stop Debug', 'Clear View', and 'NBD Version' (Check).

Time	Message	Signal	AZ_ABS	AZ_REL	EL	Heading	GPS
17:07:52	[P] Work_Search_1 Start	0	22.61	22.61	45.34	0	127.05 E 37.07 N
17:07:52	[S] Search1 Reset	0	22.61	22.61	45.34	0	127.05 E 37.07 N
17:07:55	[S] Home Sensor[N] -17.72/-18 (98%)	1	352.76	352.76	45.58	0	127.05 E 37.07 N
17:07:57	[S] Limit Initialized	2	335.86	335.86	45.49	0	127.05 E 37.07 N
17:08:00	[P] GPS1 Enabled	2	301.35	301.35	45.51	0	127.05 E 37.07 N
17:08:10	[P] 2 Level 221/219	31	190.97	190.97	45.58	0	127.05 E 37.07 N
17:08:10	[S] Detect1 AZ 18671/0 (0)	31	190.97	190.97	45.58	0	127.05 E 37.07 N
17:08:15	[P] Mainlobe 315/(199+20*2)	156	184.53	184.53	45.32	0	127.05 E 37.07 N
17:08:15	[P] Tracking ON	156	184.53	184.53	45.32	0	127.05 E 37.07 N
17:08:15	[P] Tracking Mode	156	184.53	184.53	45.32	0	127.05 E 37.07 N
17:08:15	[P] Correct Satellite	156	184.56	184.56	45.23	0	127.05 E 37.07 N
17:08:17	[P] Point Enable	154	184.80	184.80	45.27	0	127.05 E 37.07 N
17:08:33	[P] Wrong Sat ID 2: 0x00A0[1]	143	184.46	184.46	44.69	0	127.05 E 37.07 N
17:08:34	[P] 1, 0 [20/16]4	142	184.56	184.56	44.65	0	127.05 E 37.07 N
17:08:54	[P] 0, 1 [40/20]4	144	185.09	185.09	44.05	0	127.05 E 37.07 N
17:09:00	[S] Tilt[2] [-30] 7/6 (4 267) -3	142	185.18	185.18	44.03	0	127.05 E 37.07 N
17:09:00	[S] Tilt[2] [-33] 5/6 (4 299) -3	142	185.18	185.18	44.03	0	127.05 E 37.07 N
17:09:00	[S] Tilt[2] [-36] 8 (4 300)	142	185.18	185.18	44.03	0	127.05 E 37.07 N
17:09:00	[S] Bias Correction 1	142	185.18	185.18	44.03	0	127.05 E 37.07 N
17:09:00	[P] Result[P1 2] [S1 3]	142	185.18	185.18	44.03	0	127.05 E 37.07 N
17:09:00	[P] 0, 1 [46/20]4	143	185.04	185.04	43.95	0	127.05 E 37.07 N
17:09:01	[S] EL/CL -190 / -199(-52), 7	143	185.08	185.08	43.87	0	127.05 E 37.07 N
17:09:01	[P] 0, 2 [47/20]4	142	185.08	185.08	43.93	0	127.05 E 37.07 N
17:09:02	[P] 0, 1 [48/20]4	141	185.02	185.02	43.85	0	127.05 E 37.07 N
17:09:03	[P] 0, 2 [49/20]4	142	185.06	185.06	43.87	0	127.05 E 37.07 N

- **Tracking:** turns on or off the dish scan function. If the dish scan function is disabled, the antenna will stop adjusting the antenna pointing angle in order to optimize the receive signal level.
- **Rate Sensor Bias:** is used to calibrate the DC voltage output from the three rate sensors (azimuth, elevation, and cross-level). These are used to sense antenna motion that corresponds to the ship's motion (roll, pitch, and yaw) for stabilizing the pedestal. You can find the same function in Antenna-Advanced View Tab.
- **Tilt Sensor Bias:** displays the EL and CL Tilt Bias between the antenna and the sensor.
- **FSK:** check the current FSK version and the signal level and verify the signal level through the result value. (Good, Bad, Worst, N/A)
- **Show Param:** shows the current antenna parameters.
- **Check NID:** verifies the NID (network ID) of the current tracking transponder. Press the NID button to obtain the NID only if the antenna is locked onto the desired satellite.
- **Debug (Start):** starts the debug log of the antenna. The debug message will be displayed once the debug button is pressed.
- **Stop Debug:** stops debug logging of the antenna.
- **Save Debug (Start/Stop):** starts or stops saving the debug log. This button is enabled once the Start Debug button is pressed.
- **Clear View:** clears the debug message or log data in monitoring window.

6. Diagnostic / Modem

This view provides Antenna Diagnostic Testing and also provides functions to set up the interface between the ACU and the Intellian VSAT Mediator or the satellite modem.



- **Diagnostic:** select to run a full diagnostic test or single diagnostic test. "Green" indicator is displayed for the test under progress. "Blue" indicates the test result as Pass while "Red" indicates the result as Fail. "Yellow" indicates the test has been skipped.
 - **Serial Comm.:** tests the data communication between the antenna and the ACU.
 - **Motor AZ:** tests the azimuth motor.
 - **Motor EL:** tests the elevation motor.
 - **Motor CL:** tests the cross-level motor.
 - **Encoder AZ:** tests the azimuth encoder.
 - **Encoder CL:** tests the cross-level encoder.
 - **Rate sensor:** tests the rate sensor.
 - **Tilt Sensor:** tests the tilt sensor.
 - **Home sensor:** tests the home sensor.
 - **ACU power:** tests the ACU power to see whether or not it is within the nominal operating range.

- **Antenna power:** tests the antenna power to see whether or not it is within the nominal operating range.
 - **Skew:** tests the LNB skew motor.
 - **LNB/ NBD:** tests the LNB and NBD (narrow band detector).
 - **Sensor Box Limit:** tests the sensor box motor.
- **Modem:** sets the interface between the ACU and the Intellian Dual VSAT Mediator or the satellite modem.

NOTE: Before setting this function, make sure connection of a RJ45 cable from the Ethernet connector on the ACU to the modem or connect a 9 pin serial cable from the RS232/422 connector on the ACU to the modem.

- **Use Mediator:** enables use of the Intellian Dual VSAT Mediator. Use Mediator must be set to "NO" if there is no MEDIATOR connected to the ACU. Improper setting of this parameter will cause your ACU's modem interface to not work correctly.
- **Select Modem:** selects your modem type for loading pre-configuration settings. If the ABS (auto beam switching) function is in use, select either IDIRECT-AMIP or COMTECH-ROSS depending on which type of modem is used.
- **Modem Port:** select the proper data communications port (RS232/ 422/ Ethernet) to interface with the modem.
- **Modem Protocol:** selects a proper communications protocol on the ACU to interface with the modem (I/O Console/ Open AMIP/ Serial GPS/ ROSS/ VCAP/ ELEKTRIKOM AMIP/ GILAT-SE-II).
- **GPS Out Protocol:** selects GPS Out Sentence type (GPGLL/ GPGGA/ Simple GPGGA).
- **Use TX Mute:** selects whether or not to use the "TX Mute" function from the satellite modem. A transmit inhibit output from the ACU will disable/ mute the modem transmit via a voltage change whenever the antenna is blocked, searching, or pointed 0.5 degrees off from the peak satellite position.

- **Use Modem Lock:** selects whether or not to use external lock signal from the modem. "Use Modem Lock" will only be activated when the modem protocol is set as I/O Console.
- **TX Mute:** TX Mute is a transmit inhibit output from the ACU to disable / mute the modem transmit through a 5 V (HIGH) or 0 V (LOW) current whenever the antenna is blocked, searching, or pointed 0.5 degrees off from peak satellite position. TX Mute will only be activated when modem protocol is set as I/O console.
- **Modem Lock:** is the modem lock output from the modem. It provides a logic input through a 5V (HIGH) or 0 V (LOW) current to the ACU to identify when the system is on the correct satellite. "Modem Lock" will only be activated when modem protocol is set as I/O Console.
- **Quick Search:** When a Quick Search set to ON, the antenna go to tracking mode quickly. (When the satellite signal is enough to higher than threshold level, the antenna go to tracking mode immediately). If a Quick Search set to OFF, the antenna compare the full signal pattern during the search3, then go to tracking mode. So, you can see that the antenna is moving back a little when it go to tracking mode.
- **Modem Verify:** When a Modem Verify set to ON, the antenna go to tracking mode only in case of Modem Lock On. The modem dependency is increased. If it is OFF, the antenna can go to tracking mode in case of Modem Lock On or Off.
- **Networkv:** displays the ACU's Internal IP addresses and ports. To modify the ACU's Internal IP addresses and ports, press the "Set" button. When changes are complete, press "Save & Reboot" button and wait for several seconds. Then press "Get" button to validate the changes.
 - IP: Factory default (Primary:192.168.0.223)/(Secondary:10.10.1.1).
 - Subnet Mask: Factory default (255.255.255.0).
 - Gate way: Factory default (192.168.1.1).
 - DNS: Current default DNS Address is assigned to.
 - TCP Port: TCP port number for modem protocols using TCP as transport.
 - UDP Port: UDP port number for modem protocols using UDP as transport.

7. GUI

This view shows a graphical representation of the current antenna position which allows you to easily identify whether or not the antenna is aligned properly to the target satellite or is in a block zone. In addition, this view shows the current satellite that the antenna is pointed towards and the satellites that are located in an 180° arc on the horizon, according to the current position.

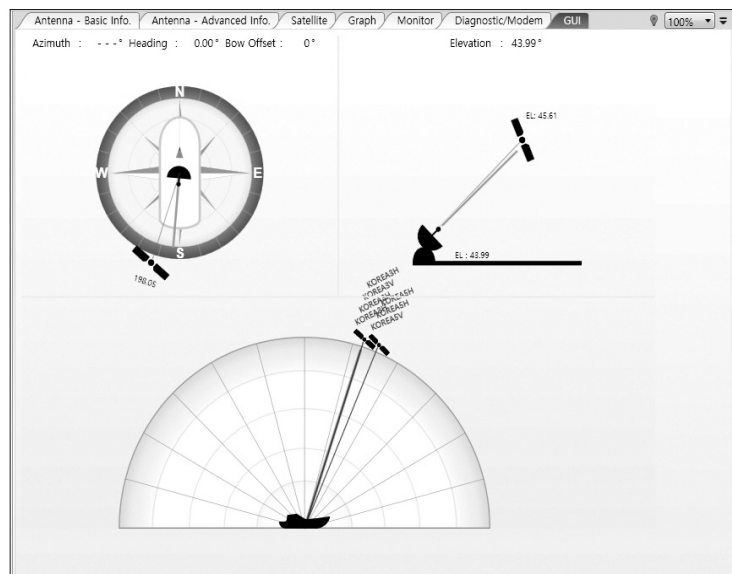

NOTE: Based on the satellite EIRP footprint and the size of the antenna, you may not be able to track all the satellites visible in 180° arc.

8. Work View Functions

The seven Work View Tabs displayed in the Work View can be arranged in customized layouts.

- Layout Formatting

Each of the Work View Tab can be separated from the rest Tabs. Click and hold the left mouse button on the Work View Tab's header and then drag a desired Tab out. When a Work View Tab is separated from the rest of your Work View Tabs, again click and hold the left mouse button on the Work View Tab's header to display a cross-shaped Navigator icon. While holding the mouse button, bring the selected Work View Tab closer to the Navigator icon and release the mouse button at your desired position (top, left, right or bottom arrow). This time, the selected Tab will be moved to the desired position.

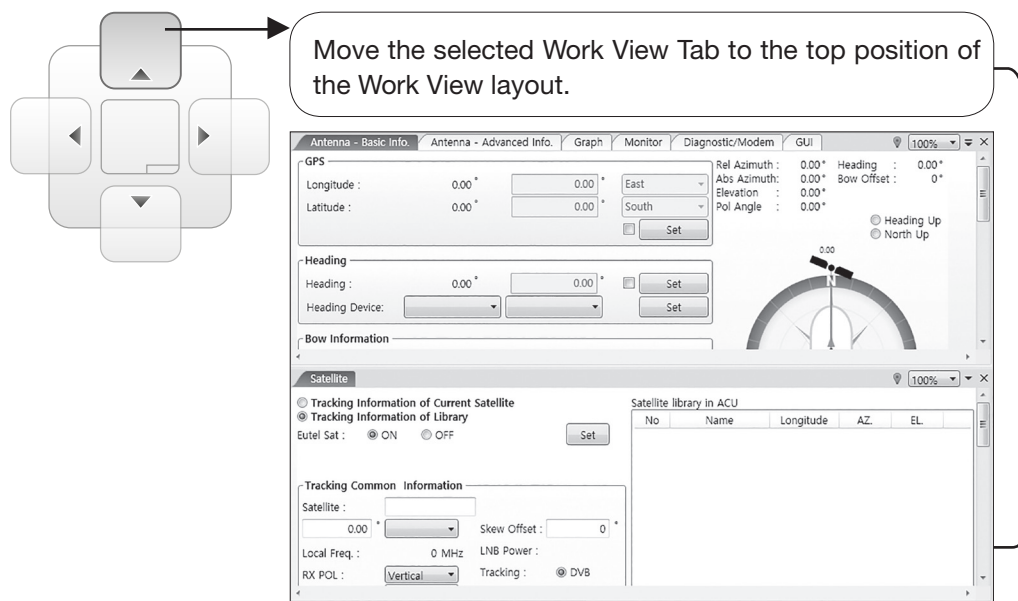

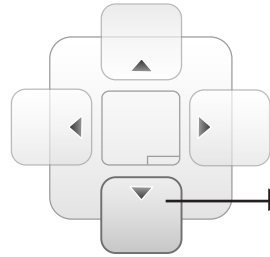

Move the selected Work View Tab to the bottom position of the Work View layout.

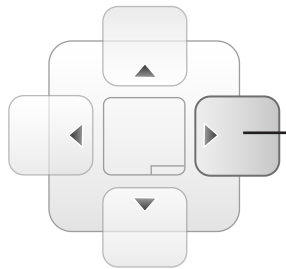

Move the selected Work View Tab to the right position of the Work View layout.

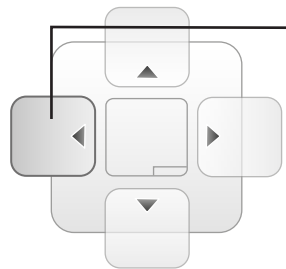

Move the selected Work View Tab to the left position of the Work View layout.

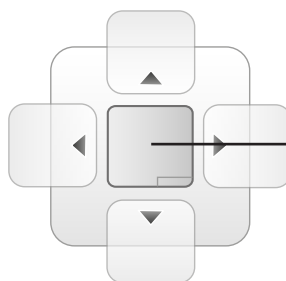

Move the selected Work View Tab to the center position of the Work View layout.

You can also drag multiple Work View Tabs into a customized layout in the same manner. Click and hold left mouse button on each Work View Tab's header and drag it onto a desired arrow on the Navigator icon. Then each Work View Tab can be placed to the desired positions as shown in the figure below.

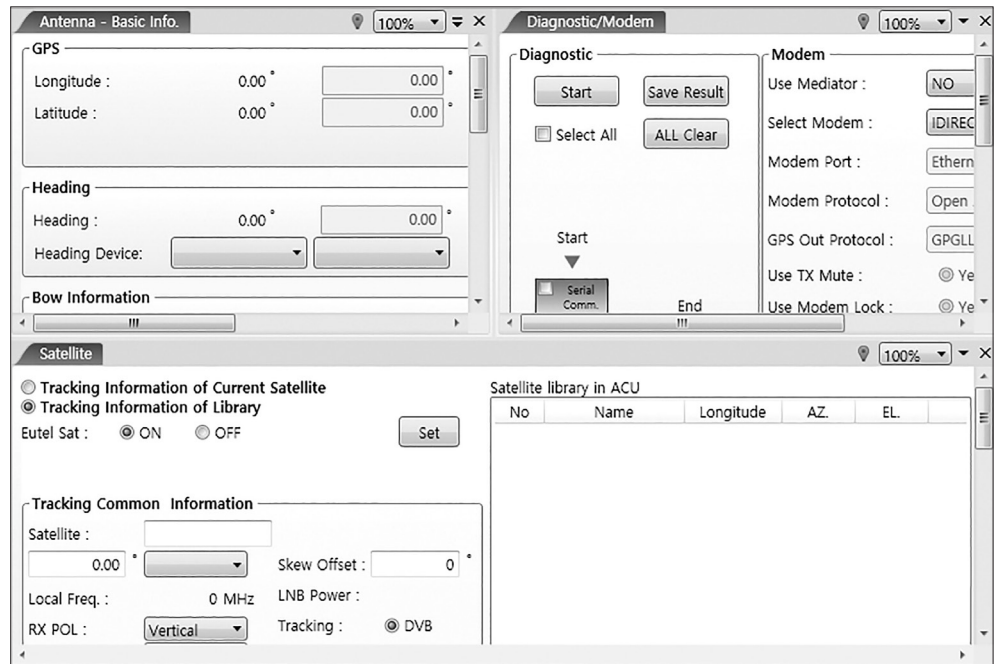

The Navigator will appear in each area your mouse pointer is located. To return to the default layout, select the Default Layout under View>Layout Manager in the tool bar menu.

- **Horizontal or Vertical Tab Group**
 The Work View Tabs can be also aligned horizontally or vertically. Without dragging them out, right-click the mouse button on a desired Tab header and select 'New Horizontal Tab Group' or 'New Vertical Tab Group' option. Selecting 'New Horizontal Tab Group' will separate a selected Tab from the rest of other Tabs then arrange it in a horizontal format. Likewise, selecting 'New Vertical Tab Group' will separate a selected Tab from the rest of other Tabs then arrange it in a vertical format.
- **Closing the Work View Tab**
 To close the Work View Tab, right-click the mouse button on a desired Tab header and select 'Close' option in the drop down list. To close all Work View Tabs except for the selected Tab, select 'Close All But This' option in the drop down list.

- Zoom Tool

Using the Zoom tool, you can easily select the magnification you want by using Zoom In and Zoom Out bar, and Fit in Work View button.



Fit Work View Button: fits the current view to the Work View window size. The button toggles between the fit view and the previous view.

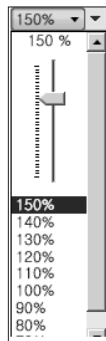

Zoom In and Zoom Out Bar: zooms in and out to expand and reduce the View to the desired size. (The zoom changes in 10% increments.)



View Switch Button: displays a list of the current views in a list. Choosing one of these views will display the selected view in the Work View window.



View Name Button: displays the current Work View name.



Close View Button: closes the current view.

APTUS WEB

Introduction

Main Page

Page Login
Top Menus
Dashboard & Information

Antenna Settings

Ship Setting
Antenna Position & Parameters
Tracking Setting
Modem Setting
Diagnostic
Library Setting

Firmware & Configuration

Antenna Firmware Upgrade
Antenna Log
Antenna Backup & Restore

Administration

Network Setting
SNMP Setting
User Management
iARM Upgrade
iARM Save & Reboot
Antenna Event Log
Intellian Network Devices

Introduction

With embedded Aptus Web software, the v-Series can be monitored, controlled, and diagnosed remotely from anywhere, anytime through the TCP/IP protocol. This can not only save time, but also can save the cost generated from the hundreds of routine maintenance activities such as operating firmware upgrades, tracking parameters reset, and system diagnostic.

How to access Aptus Web:

1. Connect an Ethernet Cable between your PC and the Management Ethernet Port.
2. Enter the ACU's IP address (192.168.2.1) into your web browser's address bar to login into the ACU's internal HTML page, if this system has not been changed from the ACU's factory default.

NOTE: Aptus Web can be displayed in Internet Explorer 8 or later and is also compatible with Firefox and Chrome web browsers.

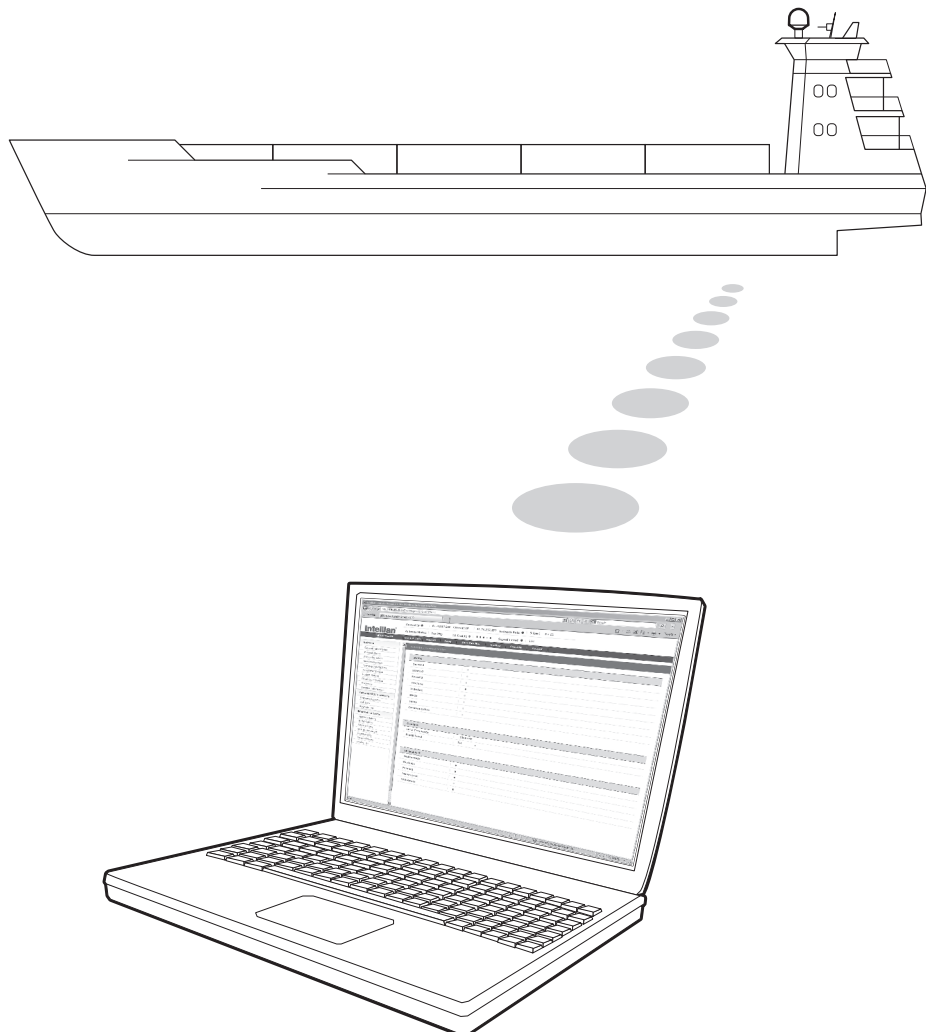

Main Page

Page Login

1. Choose either to Control & Monitor the ACU (Control & Monitoring) or Only Monitor the ACU (Monitoring Only).
2. Log into the ACU by typing in User Name and Password information. If this system has not been changed from the factory default:
 - **User Name:** intellian
 - **Password:** 12345678



Intellian®

Aptus
web

Aptus Web
V65 v1.17

Monitor & Control
 Monitor Only

Username

Password

Login Cancel



WARNING: The Control & Monitoring Mode will be switched to the Monitoring Only Mode in the following cases;

- If PC Software (Aptus) is connected using TCP/IP Communication while Aptus Web Control is in use.
- If Control & Monitoring Mode is accessed while PC Software is running via TCP/IP Communication. In this case, the web page will display a pop-up message asking if you want to disconnect the PC Software network connection. If you select 'No', the Control & Monitoring Mode will be switched to the Monitoring Only Mode.

Top Menus

Once you log in, the following information and menus are displayed.

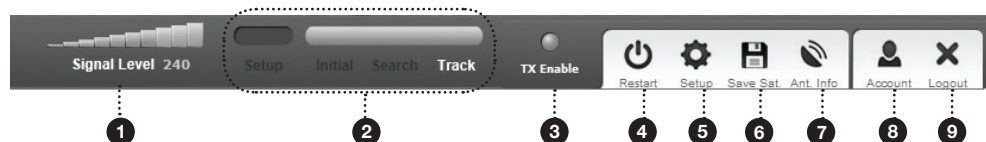

No.	Item	Description
①	Signal Level	Display current signal level.
②	Antenna status	<ul style="list-style-type: none"> - Setup: Displays whether or not the antenna is in SETUP mode. The indicator shows "Blue" in the SETUP mode. - Initial: Antenna or ACU is initialized. - Search: Antenna is searching a target satellite. - Track: Antenna is tracking the target satellite.
③	TX Enable/ TX Disable	Displays whether or not the antenna is able to transmit the data
④	Restart	Restart the antenna system.
⑤	Setup	Enter SETUP mode.
⑥	Save Sat.	Save current satellite settings. Bow offset will be adjusted and saved automatically.
⑦	Ant. Info	Obtain current antenna information.
⑧	Account	Shortcut to User Management menu. Change login ID and Password.
⑨	Logout	Logout the ACU's internal HTML page.

Dashboard & Information

On the left side of the page, Dashboard and Information menus are displayed as below to provide quick monitoring of the antenna status and settings. Other menus are displayed only in the Control & Monitoring mode and their functions will be described in the next sections.

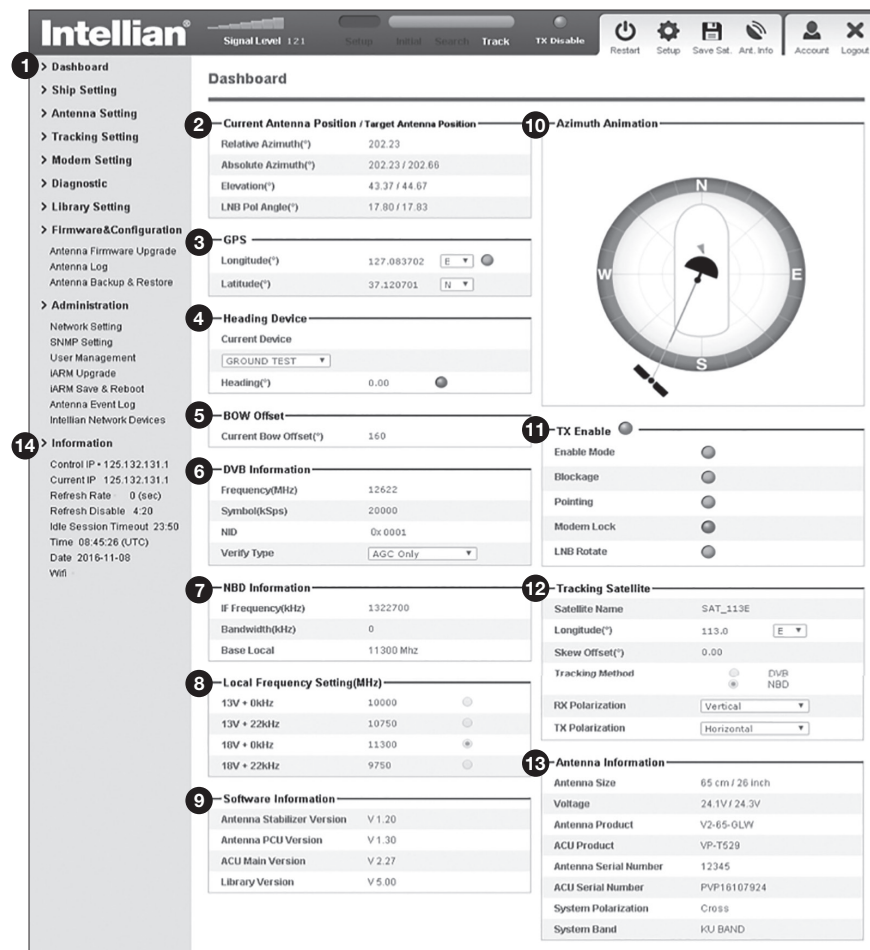

No.	Item	Description
①	Dashboard	Displays current antenna status to be quickly monitored.
②	Current Antenna Position / Target Antenna Position	Displays current antenna position. - Relative Azimuth: displays antenna relative AZ angle. - Absolute Azimuth: displays antenna absolute AZ angle. - Elevation: displays antenna elevation angle. - LNB Pol Angle: displays LNB pol angle.
③	GPS	Displays current GPS information. - Longitude (East / West) - Latitude (North / South)

No.	Item	Description
④	Heading Device	Displays current Heading Device: NONE, NMEA, NMEA 2000, Ground test If the ship's gyrocompass input is other than NMEA separate purchase of NMEA Converter is required. - Heading: displays ship's heading information.
⑤	BOW Offset	Display current bow offset
⑥	DVB Information	Displays DVB tracking mode's current tracking information. - Frequency: displays tracking frequency. - Symbol rate: displays symbol rate. - NID: displays network ID. - Verify type: displays verification type (AGC, DVB, DVB Decode)
⑦	NBD Information	Displays NBD tracking mode's current tracking information. - Frequency: displays tracking IF frequency. - Bandwidth: displays detection bandwidth.
⑧	Local Frequency Setting (MHz)	Displays current LNB's local frequency and voltage
⑨	Satellite Information	Displays current Antenna and ACU firmware versions and Satellite Library version installed in the system. - Antenna Stabilizer Version - Antenna PCU Version - ACU Main Version - Library Version
⑩	Azimuth Animation	Shows a graphical representation of the current antenna position to identify whether or not the antenna is aligned properly to the target satellite or is in a block zone.
		Displays whether or not the antenna is able to transmit the data. The TX function will be enabled (shows BLUE dot) only if all of the factors listed below show "BLUE" dot. Exception: If "Use TX Mute" is set as "NO", the TX function will be enabled regardless of which factor listed below shows a "gray" dot or "red" dot.
⑪	TX Enable	The function below will be enabled with a BLUE dot displayed as listed below: - Enable Mode: antenna is not in SETUP mode. - Blockage: antenna is not facing the predefined block zone(s). - Pointing: antenna is pointing to the target satellite. - Modem Lock: satellite modem is sending a logic input to the ACU to identify when the antenna tracks on the correct satellite. - LNB Rotate: LNB is not rotating.

No.	Item	Description
⑫	Tracking Satellite	Displays current tracking mode. <ul style="list-style-type: none">- Satellite: displays satellite name.- Longitude: displays satellite orbit position.- Skew Offset: displays Skew offset.- Tracking Method: displays current tracking mode (DVB/ NBD).- RX Polarization: displays current RX polarization.- TX Polarization displays current TX polarization.
⑬	Antenna Information	Displays the product information
⑭	Information	<ul style="list-style-type: none">- Control IP: Displays current IP that controls the ACU.- Current IP: Displays current IP address.- Refresh Rate: Displays screen refresh rate (default: 1 sec.)- Refresh Disable: Displays time out. The screen will not refresh once the time-out shows 0:00.- Exception: If the Refresh Disable Time is set to "OFF" in the Network Setting page, then the clock will show "--:--" and system will keep monitoring all activities regardless of timeout.- Time: Displays UTC time.- Date: Displays UTC date.- Wifi: Displays Wifi on/off switch.

Antenna Settings

Ship Setting

No.	Item	Description
①	Ship Setting	Set the ship information and block zone.
②	GPS	Set GPS information. - Longitude (East/West) - Latitude (North/South)
③	Bow Offset	Set Bow Offset if needed.
④	Heading Device	Set ship's heading device (NONE, NMEA, NMEA2000, Ground Test) and ship's heading information.
⑤	Blockage	Set up to five antenna block zones by azimuth and elevation sectors. AZ. START is where the relative azimuth starts and AZ. END is where the relative azimuth ends (Range: 0 - 360°). EL is where the elevation blockage starts (Range 0 - 90°).



WARNING: Enter the SETUP mode for configuration. Tick the checkbox before modifying the settings. After configuration, click 'Set ...' button to submit the settings.

Antenna Position & Parameters

No.	Item	Description
①	Antenna Setting	Set current antenna position and Search and Tracking parameters. These parameters should only be changed by an authorized service technician. Improper setting of these parameters will render your system inoperable.
②	Current Antenna Position / Target Antenna Position	Display current antenna position. - Relative Azimuth: display antenna relative AZ angle. - Absolute Azimuth: display antenna absolute AZ angle. - Elevation: display antenna elevation angle. - LNB Pol Angle: display LNB pol angle. - Heading: display ship's heading information.
③	Manual Movement	Move antenna azimuth and elevation angles and LNB pol angle to find the desired satellite manually. LNB Pol Angel can be adjusted at any time either in SETUP Mode or Tracking Mode.
④	LNB Pol Sensor Calibration	Calibrate the LNB pol angle when the control board, potentiometer or belt is replaced.
⑤	Elevation Adjust	Adjust the elevation to offset the angle difference between the mechanical elevation angle and actual elevation angle.

No.	Item	Description
⑥	Conical Range	The relative force of the motors controlling azimuth and elevation. Set the conical range while the antenna is in tracking mode.
⑦	Idle Mode	Release the elevation and cross level motor brakes while the antenna is in SETUP mode. The antenna can be moved manually during the mode.
⑧	Reboot	Reboot the system.
⑨	Search & Tracking Parameter Setting	<ul style="list-style-type: none"> - DVB Detect and Tracking Level Threshold: display / set current detect level threshold and tracking level threshold when DVB tracking mode is chosen to be used. - NBD Detect and Tracking Level Threshold: display / set current detect level threshold and tracking level threshold when NBD tracking mode is chosen to be used. - TX Enable Threshold: display / set TX enable threshold. - Wait time: set the time-out for automatic initiation of a search after the signal level drops below the pre-defined threshold value. - Search Step: set increment step size. - Search 1 & 3 Range: set Search 1 & 3 search range. Search is conducted in a two-axis pattern consisting of alternate movements in azimuth and elevation as forming an expanding square. - Search 2 Range: is reserved for future use.
⑩	Tilt Sensor Bias	Adjust the two solid-state tilt sensors used to provide absolute cross-level tilt of the antenna and elevation feedback to eliminate long-term pointing drift (error). Tilt bias is required to be adjusted when the antenna control board or sensor box is replaced. Check to see whether or not the bubble is located at the center of the level vial.
⑪	Rate Sensor Adjust	Calibrate DC voltage output from the three rate sensors used to sense antenna motion in azimuth, elevation and cross-level axes. During the calibration process, the antenna should avoid any motion as it can affect the antenna's performance.



WARNING: Tick the checkbox before modifying the settings. After configuration, click 'set...' button to submit the settings.

Tracking Setting

No.	Item	Description
①	Tracking Setting	Display or set current tracking mode and tracking frequency of the target satellite.
②	Local Frequency Setting (MHz)	Display and set LNB's local frequencies. Display current LNB local frequency which is in use and voltage.
③	Current Satellite Setting	Display and set current satellite setting.
④	Tracking Satellite	Display and set current tracking mode. <ul style="list-style-type: none"> - Satellite: display and set satellite name. - Longitude: display and set satellite orbit position. - Skew Offset: display and set Skew offset. - Tracking Method: display and set current tracking mode (DVB/ NBD). - RX Polarization: display and set current RX polarization. - TX Polarization display and set current TX polarization.
⑤	DVB Information	Display and set DVB tracking mode's tracking information. <ul style="list-style-type: none"> - Frequency: display and set tracking frequency. - Symbol rate: display and set symbol rate. - NID: display and set network ID. - Verify type: display and set verification type (AGC, DVB, DVB Decode)
⑥	NBD Information	Display and set NBD tracking mode's tracking information. <ul style="list-style-type: none"> - Frequency: display and set tracking IF frequency. - Bandwidth: display and set detection bandwidth.



WARNING: Tick the checkbox before modifying the settings. After configuration, click 'set...' button to submit the settings.

Modem Setting

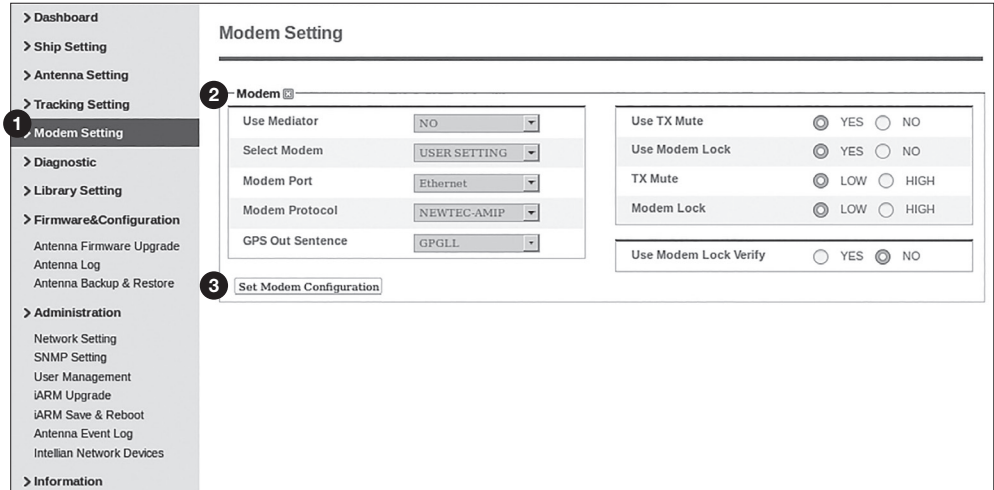

No.	Item	Description
①	Modem Setting	Set the modem interface.

- Use Mediator: enable the usage of Mediator if the antenna is connected to the Intellian Dual VSAT Mediator. Use Mediator must be set to "NO" if there is no MEDIATOR connected to the ACU. Improper setting of this parameter will cause your ACU's modem interface to not work correctly.
- Select Modem: is to select a proper data communication port and protocol on the ACU to interface with the satellite modem. The settings related to the modem interface will be set automatically once the modem type is selected (USER SETTING, IDIRECT-I/O, IDRECT-AMIP, COMTECH-I/O, COMTECH-ROSS, HUGHES, SATLINK-SERIAL, SATLINK-VACP, ELEKTRIKOM-AMIP, GILAT-SE-II, IPSTAR_SOTM, INMARSAT G5, NEWTEC-AMIP). However, if USER SETTING is selected, it is required to set the related settings separately.
- Modem Port: is to select a proper data communication port on the ACU to interface with the satellite modem (RS232/422/ Ethernet).
- Modem Protocol: is to select a proper communication protocol on the ACU to interface with the modem (I/O Console, OpenAMIP, Serial GPS, ROSS, VACP, ELEKTRIKOM AMIP, GILAT, SOTM, G5, NEWTEC-AMIP).
- GPS Out Sentence: is to select the GPS out sentence type (GPGLL/GPGGA/SIMPLE GPGGA).
- USE TX Mute: is to select whether or not to use TX mute function from the satellite modem.
- USE Modem Lock: is to select whether or not to use external lock signal from the satellite modem.

No.	Item	Description
②	Modem	<ul style="list-style-type: none"> - TX Mute: is a transmit inhibit output from the ACU to disable/mute the modem transmit through a 5V (High) or 0V(LOW) current whenever the antenna is blocked, searching, or is 0.5° off from peak satellite position. - Modem Lock: is the modem lock output from the modem which provides a logic input through a 5V (High) or 0V(LOW) current to the ACU to identify when it is on the correct satellite. - Use Modem Lock Verify: Verify the target satellite using the modem lock signal. <p>NOTE: TX Mute and Modem Lock items will only be activated when the modem protocol is set as I/O Console.</p>
③	iDirect Modem Monitor (OpenAMIP only)	<p>Displays iDirect Modem status and control connection. This menu appears only when IDIRECT-AMIP protocol is selected at Modem Setting page.</p> <ul style="list-style-type: none"> - Connection: control modem connection. - Modem IP: iDirect modem IP. - Port: Connection ID for telnet. - Password: Connection password for telnet. - Start(Stop): Connect to telnet or disconnect. - Auto Connect: Enabling Auto Connect and rebooting the ACU will save connection data and will auto connect once ACU is powered on next time. - Status: Displays iDirect modem status. - Last Update Date: Displays last updated data and time of the iDirect modem data. - Connect: Displays connection status (INACTIVE, CONNECTING, LOGGEDIN, Black data indicates being INACTIVE). - RX SNR: Displays RX SNR data. - View Detail Information: Select to view detail information. - Status: Displays last update date and connection status. - Information: Displays rx snr, tx power, tx power min, rx power, tx power max, tx power, ref, latlong. - Option File Information: Displays information about VERSION, MOBILE, LOCAL and ACU PORT.



WARNING: Ensure to tick the checkbox before modifying the settings. Select 'Set Modem Configuration' to confirm the modem settings configured.

Diagnostic

No.	Item	Description
①	Diagnostic	Execute antenna diagnostic test. Select to run a full diagnostic test or single diagnostic test. <ul style="list-style-type: none"> - Serial Comm.: test the data communication between the antenna and the ACU. - Motor AZ: test the azimuth motor. - Motor EL: test the elevation motor. - Motor CL: test the cross-level motor. - Encoder AZ: test the azimuth encoder. - Encoder CL: test the cross-level encoder.
②	Diagnostic	<ul style="list-style-type: none"> - Rate Sensor: test the rate sensor. - Tilt Sensor: test the tilt sensor. - Sensor Box Limit: test the sensor box motor. - LNB/NBD: test the LNB. - SKEW: test the LNB pol motor. - Antenna Power: test the antenna power. - ACU Power: test the ACU power. - Home Sensor: test the home sensor. - Test ALL: test all devices.

No.	Item	Description
③	Graph	Select to view a graph of AZ Absolute, AZ Relative, EL and Heading data of the antenna. - A Month: display all data within a month - A Week: display all data within a week - A Day: display all data in a day - Real-time: display data in real time. Press F5 button to refresh. - Data Num: set the maximum number of graph data set to be displayed. - View Graph: select to view the data graph.
④	Spectrum	Select to view a current spectrum graph and to set the spectrum display options.



WARNING: Click the checkbox before modifying the settings. Click Diagnosis button to execute diagnostic test. To clear previous diagnosis result, click Diagnosis Clear button.

Library Setting

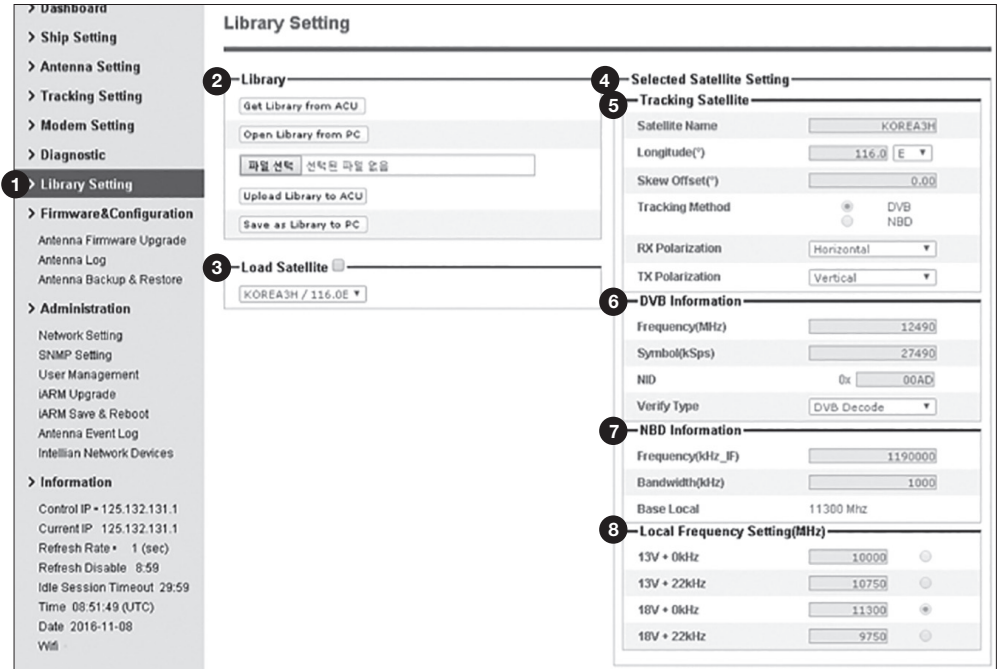

No.	Item	Description
①	Library Setting	Display and set the satellite library information.
②	Library	<ul style="list-style-type: none"> - Get Library from ACU: Obtain satellite information installed in the ACU. - Open Library from PC: open the satellite library file from the supplied Intellian CD or from the external hard drive/PC. (File format: *.ilf) - Upload Library to ACU: upload the satellite library file to ACU. - Save as Library to PC: save the current library setting to the PC.
③	Load Satellite	Select the satellite that you wish to track and press Load Satellite button to load the selected satellite.
④	Selected Satellite Setting	Displays selected satellite information.
⑤	Tracking Satellite	<ul style="list-style-type: none"> - Satellite: displays satellite name. - Longitude: displays satellite orbit position. - Skew offset: displays Skew offset. - Tracking method: displays current tracking mode (DVB/NBD). - RX polarization: displays current RX polarization. - TX polarization: displays current TX polarization.
⑥	DVB Information	<ul style="list-style-type: none"> - Displays DVB tracking mode's tracking information. - Frequency: displays tracking frequency. - Symbol rate: displays symbol rate. - NID: displays network ID. - Verify type: displays verification type (AGC only, DVB lock, DVB decode, DSS decode).
⑦	NBD Information	<ul style="list-style-type: none"> - Displays NBD tracking mode's tracking information. - Frequency: displays tracking frequency. - Bandwidth: displays detection bandwidth.
⑧	Local Frequency Setting (MHz)	Displays LNB local frequency (MHz) and voltage.

Firmware & Configuration

Antenna Firmware Upgrade

- > Dashboard
- > Ship Setting
- > Antenna Setting
- > Tracking Setting
- > Modem Setting
- > Diagnostic
- > Library Setting
- > Firmware&Configuration
- Antenna Firmware Upgrade
- Antenna Log
- Antenna Backup & Restore
- > Administration
- Network Setting
- SNMP Setting
- User Management
- iARM Upgrade
- iARM Save & Reboot
- Antenna Event Log
- Intellian Network Devices
- > Information
- Control IP • 192.168.2.5
- Current IP 192.168.2.5
- Refresh Rate • 1 (sec)

Antenna Firmware Update

2 New Antenna Firmware

Upgrade Method Auto Upgrade

The update may take a few minutes to complete.
The upload time may vary due to a variety of factors such as the speeds of your network.
Upload an incorrect firmware file may cause serious damage to your antenna and ACU.

Press check button first. If antenna new firmware exist, you can start upgrade.
Press Check Button first

3 Current Running Version

Current Firmware Version	Antenna STABILIZERv9.01
	Antenna PCU v9.01
	ACU Main v9.00
	Library v5.00

4 Cold Rollback

Previous Package Version	Antenna STABILIZERv9.01	<input type="button" value="Rollback"/>
v161116	Antenna PCU v9.01	
	ACU Main v9.00	
Latest Package Version	Antenna STABILIZERv9.01	<input type="button" value="Rollback"/>
v161116	Antenna PCU v9.01	
	ACU Main v9.00	

No.	Item	Description
①	Antenna Firmware Upgrade	Select to update antenna firmware.
②	New Antenna Firmware	Select Upgrade Method between Manual Upgrade or Auto Upgrade. With Manual Upgrade option selected, browse and select the firmware package file to upload and click Start Upload button. With Auto Upgrade option selected, click Check button to check automatically if there is new firmware available from the server.
③	Current Running Version	Displays current firmware versions (Antenna STABILIZER, Antenna PCU, ACU main, Library).
④	Cold Rollback	Display Previous/Latest Package version and rollback firmware to Previous or Latest version. Other functions cannot be operated while rollback is in progress.

143

Upgrade procedures:

1. Select the upgrade package file. In Auto Upgrade mode, check new firmware file automatically by clicking Check button.
2. Click on "Start Upload" button to transfer the Firmware package file (*.fwp) to iARM module. In Auto Upgrade mode, click "Upgrade" button once new firmware file is detected.
3. After the package file is transferred, it'll show "upgrade from vx.xx Version to vx.xx Version". Enable the check box to select the firmware file that you wish to upgrade. To select all firmware files, click Select All boxes.
4. Click on "Start Upgrade" button.

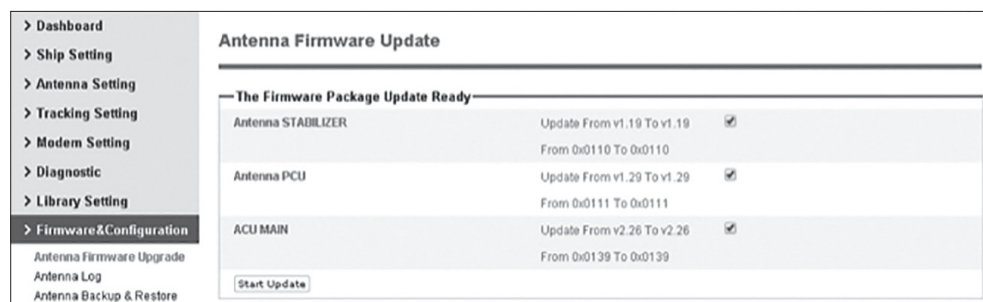

Firmware upgrade status page

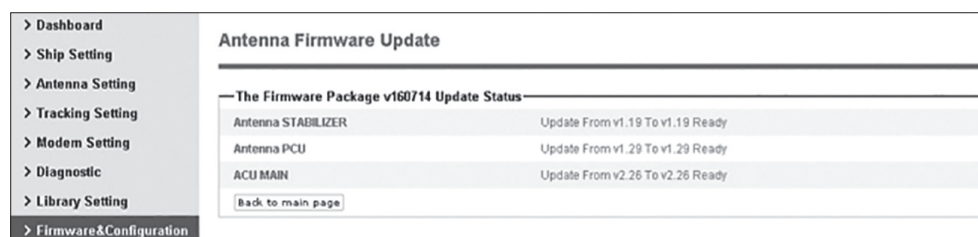

5. During upgrade process, the window will display process status.

Upgrade process status page

Antenna Firmware Update

The Firmware Package v160714 Update Status

Antenna STABILIZER	Update From v1.20 To v1.19 Success
Antenna PCU	Update From v1.30 To v1.29 60 %
ACU MAIN	Update From v2.27 To v2.26 Ready

[Back to main page](#)

6. If the firmware is successfully upgraded, it'll display "The firmware update is completed."

Upgrade complete page

The Firmware Package v160714 Upgrade Complete

Antenna STABILIZER "1.19" "Success"
 Antenna PCU "1.29" "Success"
 ACU MAIN "2.26" "Success"

The firmware update is completed.
 If you receive an fail message, please try again.
 Please refer to the User Guide if you have trouble connecting to the antenna.

[Back to main page](#)

7. Click on "Back to main page" to go out of the screen. To verify the upgraded firmware version, go to Dashboard > Software Information.

NOTE: To roll back to the previous firmware package version or latest package version, select Rollback Upgrade menu on the Antenna Firmware Upgrade page.

Antenna Log

The screenshot shows the 'Antenna Log' configuration page. On the left is a navigation sidebar with categories like Dashboard, Ship Setting, Antenna Setting, Tracking Setting, Modem Setting, Diagnostic, Library Setting, and Firmware & Configuration. The 'Antenna Log' menu item is highlighted with a circled '1'. The main content area has a title 'Antenna Log' and several sections: 'GPS Log Option' (with an 'Enable' dropdown and 'Submit/Cancel' buttons, circled '2'), 'Antenna Log Download' (with a 'Download Method' dropdown set to 'HTTP Download', date selection fields for 'Start Date' and 'End Date', and a 'Start Download' button, circled '3'), and 'Antenna Firmware Log' (a table with columns 'Date/Time(UTC 00:00)', 'STAB', 'PCU', and 'Main', circled '5'). A 'Start Download' button and an 'Include Backup/Report File' checkbox are circled '4'.

No.	Item	Description
①	Antenna Log	Displays antenna log data.
②	GPS Log Option	Disable/Enable to save GPS information in the antenna log file.
③	Antenna Log Download	Select file transfer protocol between HTTP Download or FTP Download. For the GX terminals, the default option is HTTP Download. Any log data within 3 months can be downloaded with HTTP Download option selected. Select the start and end date by manual input or mouse-scrolling on the calendar view.
④	Start Download	Select the Start Download button to download the antenna log file. Download the Back up/Report file by clicking the 'Include Backup/Restore File' check box.
⑤	Antenna Firmware Log	Displays log information of firmware upgrade(s).

Log Download procedures:

1. Select 'Start Download' button.
2. To run Java applications you must have Java Runtime Environment (JRE) version 6.0 and above installed in your PC/ laptop when you access the antenna log page for first time. Click "Run" button on the popup message "The application's digital signature cannot be verified. Do you want to run the application? " to install the Applet. Refer to Appendix for Java Installation Instructions, if the system does not display the popup message.

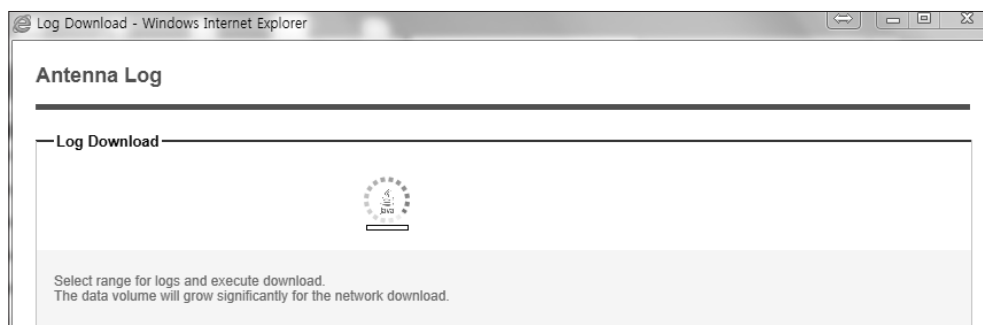

3. Select 'Browse' to browse the target directory of the antenna log file.
4. Select log period for file download.
 - Last 3 Months: download the antenna log information for the past three months.
 - Last 1 Month: download the antenna log information for the past one month.
 - Last 1 week: download the antenna log information for the past one week.
 - Last 1 Day: download the antenna log information for the past one day.
5. Select 'Download' to download the log file to the target directory according to the selected log period.

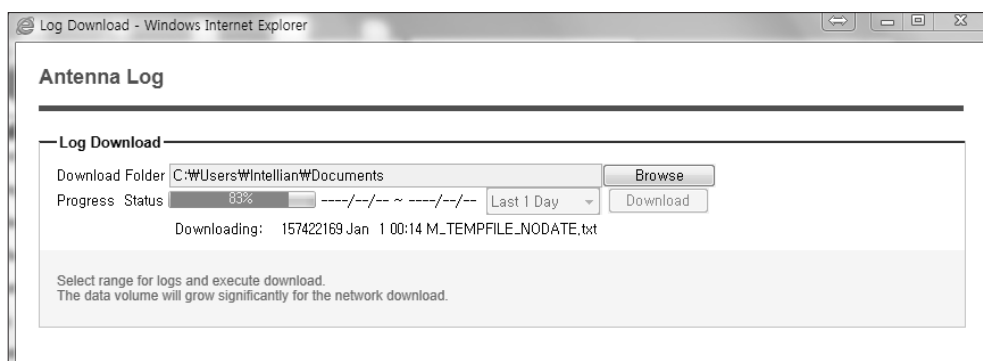

NOTE: You can choose to Enable or Disable the GPS tracking function. Liability for information that is disclosed when GPS is enabled is solely the operator responsibility and it is up to the operator on whether or not to provide their GPS information to third parties. Any issues regarding safety and privacy when turning on the GPS function is solely up to the user. Intellian is not responsible for information that is disclosed when the GPS function is enabled.

Antenna Backup & Restore

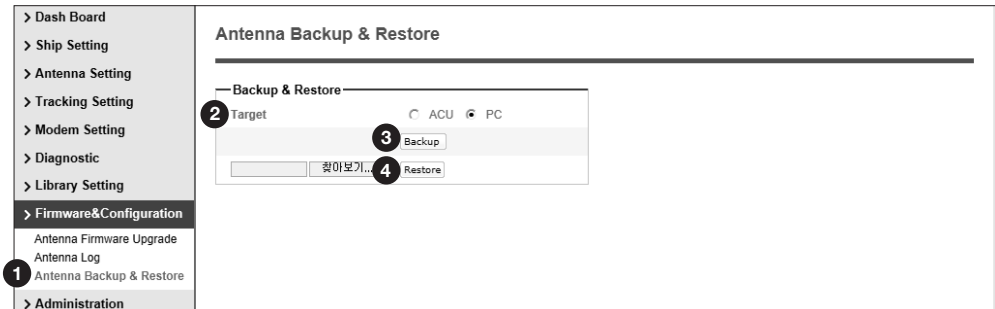

No.	Item	Description
①	Antenna Backup & Restore	Enter Backup & Restore page (Setup mode is required).
②	Target	Backup antenna information to ACU/PC or restore antenna by using the saved information from ACU/PC.
③	Backup	Backup antenna information.
④	Restore	Restore antenna information.

Administration

Network Setting

No.	Item	Description
①	Network Setting	Enter network setting page.
②	Modem Port Configuration	<p>Modify ACU's Internal IP addresses, routing, and ports. When complete press "Submit" button at bottom of page. Go to "Save & Reboot" page and press Save & Reboot button to validate the changes.</p> <ul style="list-style-type: none"> - IP Address: Factory default (Primary:192.168.0.223)/ (Secondary:10.10.1.1). - Subnet Mask: Factory default (255.255.255.0). - Gateway: Factory default (192.168.0.1). - DNS: Current default DNS Address is assigned to. - NAT Routing: Enable/Disable NAT routing. - TCP Modem Protocol Port: TCP port number for modem protocols using TCP as transport. - UDP Modem Protocol Port: UDP port number for modem protocols using UDP as transport.

No.	Item	Description
③	Management Interface Configuration	<p>Modify Management network configuration and press "Submit" button at bottom of window. Go to "Save & Reboot" page and press Save & Reboot button to validate the changes.</p> <ul style="list-style-type: none"> - IP Address: ACU front network port /Factory default (192.168.2.1). - Subnet Mask: Factory default (255.255.255.0). - Lease Start Address: Lease IP address start range. - Lease End Address: Lease IP address end range. - Lease Time: Lease IP address update time.
④	WiFi Access Point Configuration	<ul style="list-style-type: none"> - SSID: The SSID is the network name shared among all devices in a wireless network. The SSID must be identical for all devices in the wireless network. It is case-sensitive and must not exceed 32 alphanumeric characters, which may be any keyboard character. Make sure this setting is the same for all devices in your wireless network. - Channel: Select an appropriate channel from the list provided to correspond with your network settings. All devices in your wireless network must use the same channel in order to function correctly. Try to avoid conflicts with other wireless networks by choosing a channel where the upper and lower three channels are not in use. - Authentication Type: Module supports an authentication mode that the 802.11 device uses when it authenticates and associates with an access point or IBSS cell. - Password: WiFi access password. - Max Stations: Setting max stations. - Disable SSID Broadcast: Choose to Enable or Disable the WiFi SSID function.
⑤	Network Service Configuration	<ul style="list-style-type: none"> - Telnet Service: Enable or disable telnet login support. - HTTPS Port: HTTPS port number. - SSH Service: Choose to Enable or Disable the CLI access through the SSH protocol.
⑥	Sys Log Configuration	<p>Set the system log configuration. Antenna sends log messages according to emergency level. Enabling this function sends the message to your management server.</p> <ul style="list-style-type: none"> - Management Server: Sys log function enable/disable. - Server IP: Management server IP address. - UDP Port: Management port. - Message Type: Select message type (Intellian message level) to send to management server (Lower number indicates higher emergency). - Syslog Target Level: If you select this target level, the management server receives log message equal to or less than this level.

No.	Item	Description
⑦	Radius Configuration	<p>This menu is used when network administrator needs to authorize user connections via Web, SSH, PC Port, Telnet, or Console using RADIUS server.</p> <ul style="list-style-type: none">- Client: Select to enable RADIUS authentication.- Server IP: RADIUS server IP Address.- Timeout: Timeout value in seconds for the authentication process.- Server Secret: Pass-Phase. This should be matched between server and ACU.
⑧	Browser Configuration	<p>Setting refresh rate and refresh disable time.</p> <ul style="list-style-type: none">- Refresh Rate: Set the browser refresh rate (Default 1 seconds. Range 1~99).- Refresh Disable Time: Set the browser idle timeout (Default:9 minutes. Range 0~9). To use this function, check the checkbox.

SNMP Setting

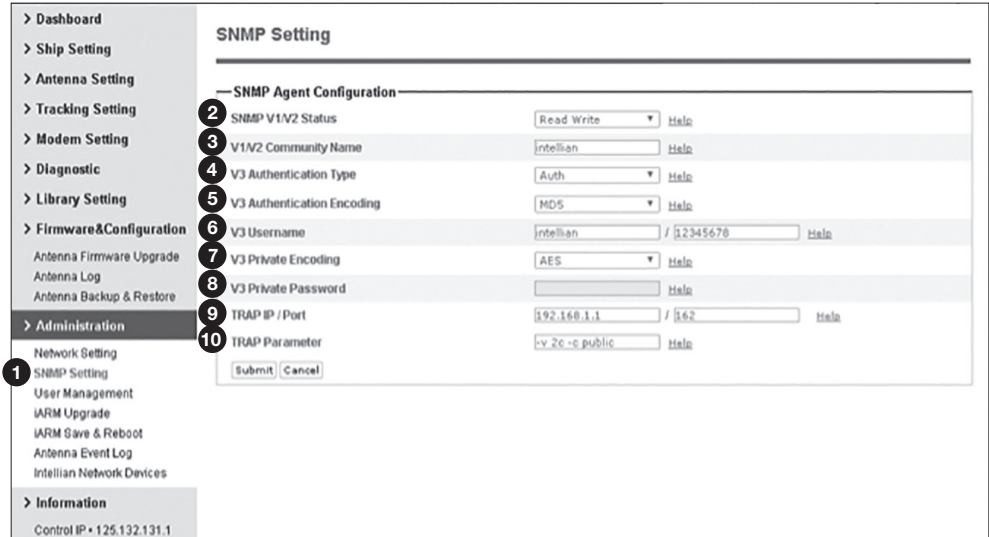

No.	Item	Description
①	SNMP Setting	Display and Set SNMP configuration.
②	SNMP V1/V2 Status	Set SNMP mode (Use Attribution Disable, Read Only or Read Write).
③	V1/V2 Community Name	Set SNMP V2 community name.
④	V3 Authentication Type	Set SNMP V3 authentication mode.
⑤	V3 Authentication Encoding	Set SNMP V3 authentication encoding.
⑥	V3 Username	Set the V3 username and password of the SNMP Agent. The password must be at least 8 character string.
⑦	V3 Private Encoding	Set SNMP V3 Private Encoding.
⑧	V3 Private Password	Set the V3 password of the SNMP Agent. The Password is must be at least 8 character string.
⑨	TRAP IP/Port	Set the V3 password of the SNMP Agent. The Password must be at least 8 character string.
⑩	TRAP Parameter	Set the SNMP trap specific parameter.

User Management

No.	Item	Description
①	User Management	Change login ID and Password to access the Aptus Web. This setting can be also accessed by 'Account' icon on the top menu.
②	Change ID & Password	Change your login ID (user name) and password. - Change ID: Enter your current login ID (user name) and new login ID. Click the Submit button to validate the changes that are made to the login ID. - Change Password: Enter your current login password and new login password. Click the Submit button to validate the changes that are made to the login password.
③	Change User Settings	Change User Password Expire in days and Idle session timeout. - Password Expire Timeout: Set password expire in days. - Idle Session Timeout: Set for Console and for Network Timeout. - Guest Session Access: Set up the guest access option.

iARM Upgrade

No.	Item	Description
①	iARM Upgrade	Upgrade the firmware of iARM module.
②	New iARM Firmware	Select Upgrade Method between Manual Upgrade or Auto Upgrade. With Manual Upgrade option selected, browse and select the firmware file to upload and click Start Upgrade button. With Auto Upgrade option selected, click Check button to check automatically if there is new firmware available from the server.
③	Bootstrap /Bootloader	Displays current bootstrap and bootloader version.
④	Kernel /File System	ACU has 4 storage parts sys0, sys1, Factory Default, and Current Active. Display kernel and file system version and current activated part Information.

iARM firmware upgrade procedures:

1. Click on "Browse" button to select the iARM firmware file (.tgz) that you wish to upgrade. In Auto Upgrade mode, check new firmware file automatically by clicking Check button.
2. Click on "Start Update" button to update the iARM firmware. Wait until the page is loaded. In Auto Upgrade mode, click "Upgrade" button once new firmware file is detected.

Firmware upgrade in progress

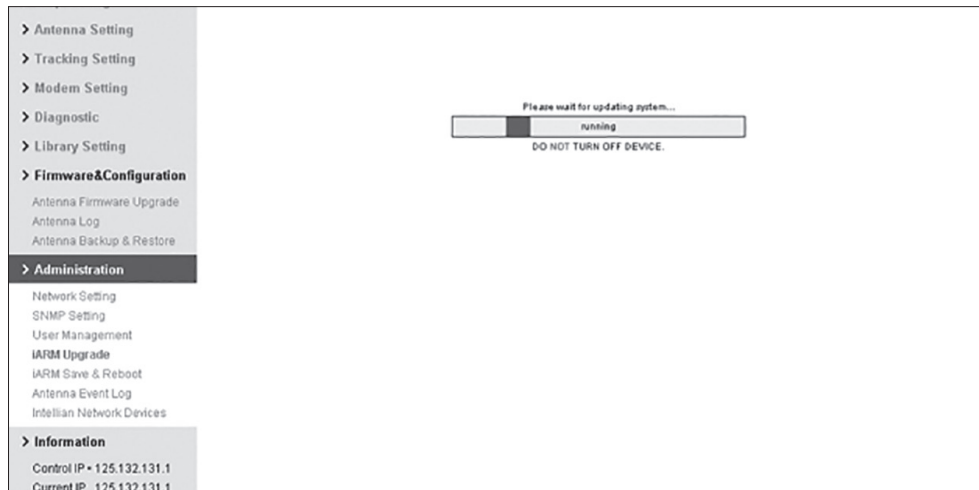

3. Once update starts, a page will indicate upgrade status. Do not turn off the ACU power if the firmware upgrade page is displayed. It should take around 2 minutes to complete the firmware upgrade.

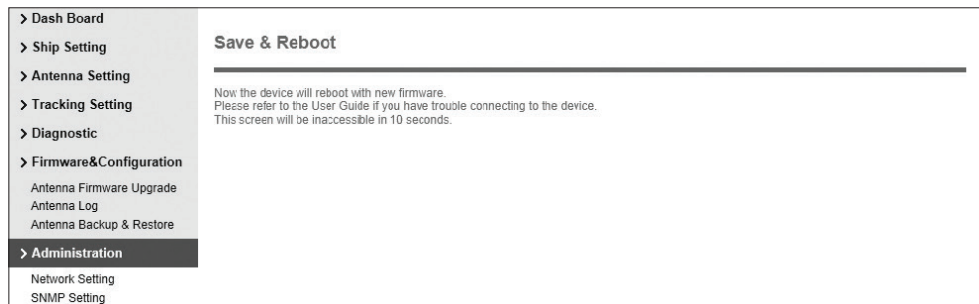

4. Once the upgrade is completed, the system will reboot automatically.

iARM Save & Reboot

No.	Item	Description
①	iARM Save & Reboot	Save settings to the ACU and reboot or reboot the system without saving.
②	Save & Reboot	Save the modified settings and reboot the system. Click Save & Reboot button.
③	Reboot without Saving	Reboot the system without saving the modified settings. Click Reboot Only button.

Antenna Event Log

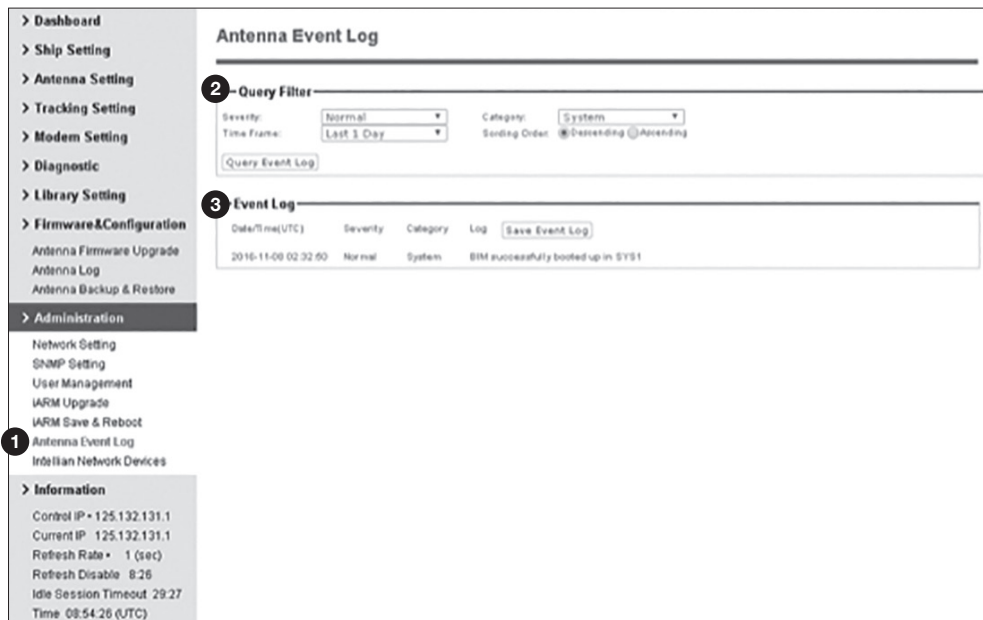

No.	Item	Description
①	Antenna Event Log	Displays user's log information (Data/Time, Login ID and IP)
②	Query Filter	Set the Log message option. - Severity: Set urgency level. - Category: Set target that caused the message. - Time Frame: Set time limit that you want to show. - Sorting Order: Sorting based on date (descending or ascending).
③	Event Log	Displays log information (Date/Time, Severity, Category, Log). - Save Event Log: Save log message to your PC.

Intellian Network Devices

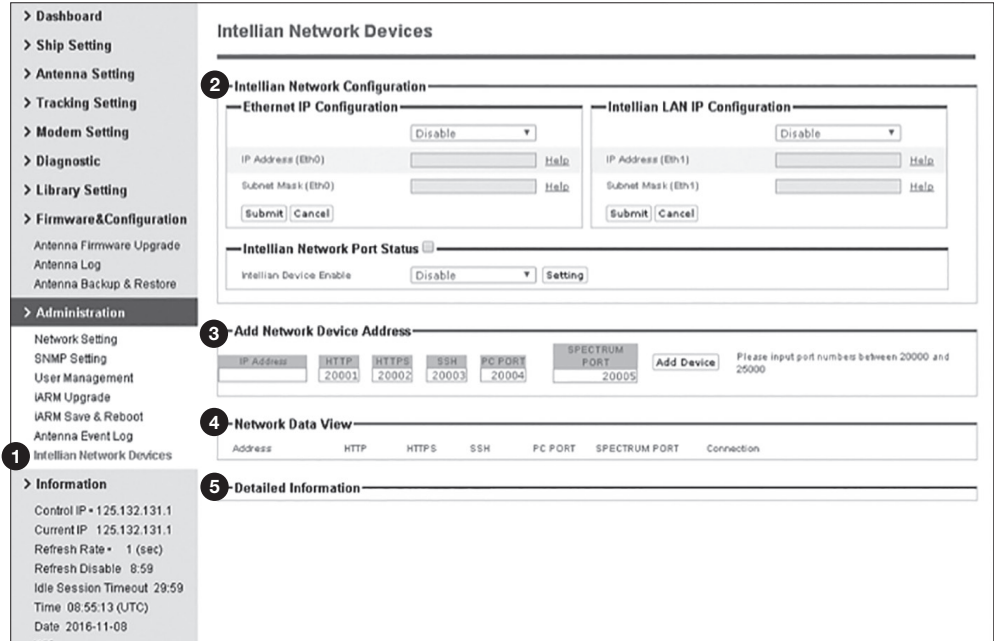

No.	Item	Description
①	Intellian Network Devices	Add up to 8 network devices and enable to monitor real time information of the connected devices.
②	Network Configuration	<ul style="list-style-type: none"> Eth0 IP Configuration: ACU network Eth0 IP and subnet mask setting. Eth1 IP Configuration: ACU network Eth1 IP and subnet mask setting. Intellian Network Port Status: not used on t-series.
③	Add Network Device Address	<p>Add Intellian network devices, then you can browse the various information of the device.</p> <ul style="list-style-type: none"> IP Address: IP address of the device to be monitored. HTTP, HTTPS, SSH: Set port number (These port numbers will be matched the http, https or SSH port number of each device).
④	Network Data View	<p>Displays the setting information of the added device (IP address, http, https, SSH port number, current connection). If you click the http/https port number of each device, then you can connect to the device's web page. If you click Delete Device button, then you can't see its information.</p>
⑤	Detailed Information	Displays the information of each device (Updated every 3 seconds).

APPENDIX: Java Download and Install Guide

NOTE: To run Java applications you must have Java Runtime Environment (JRE) version 6.0 and above installed in your PC/laptop.

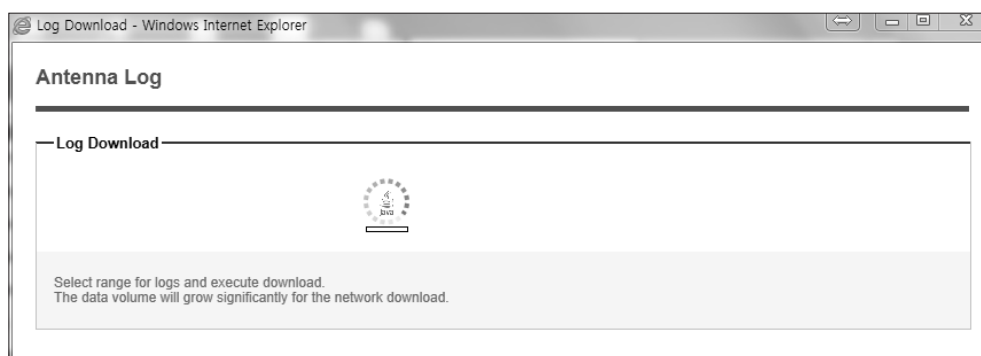

If JRE has not been installed in your PC/laptop, you'll get the below message box. Click Run button to install it through online or offline download and install methods. After installing JRE, Java Applet will be executed automatically when you access the Antenna Log page.

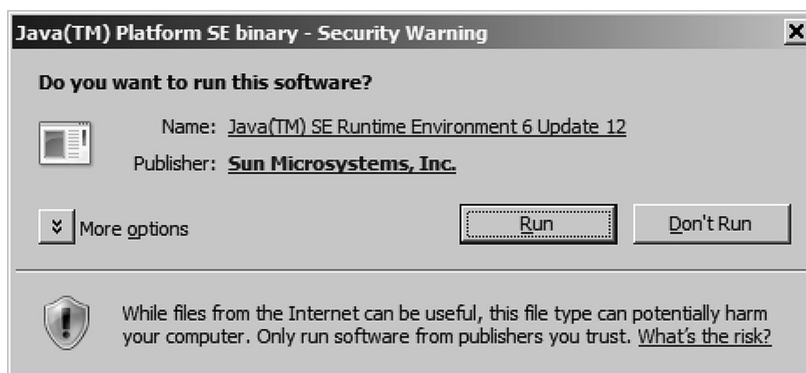

NOTE: The JRE installation guide may vary depending on the operating system installed in your PC/laptop.

Method 1. Online method for downloading and installing
<http://www.java.com/en/download/manual.jsp>

The screenshot shows the Java website's download page. At the top, there is a search bar and navigation links for 'Java in Action', 'Downloads', and 'Help Center'. The main heading is 'Java Downloads for All Operating Systems', with a sub-heading 'Recommended Version 6 Update 26'. Below this, there is a section for 'Available Operating Systems' with a sidebar menu listing 'Windows', 'Solaris', 'Linux', and 'Apple'. The main content area instructs users to select a file based on their operating system and provides links for 'Remove Older Versions' and 'What is Java?'. A disclaimer states that by downloading Java, users acknowledge they have read and accepted the terms of the 'end user license agreement'. A section titled 'Which should I choose?' lists two Windows options: 'Windows 7, XP Online' (file size: ~ 11 MB) and 'Windows 7, XP Offline' (file size: 16.0 MB). Each option has a corresponding 'Instructions' link. A 'Verify Now' link is also present. A note at the bottom provides 'information about the 64-bit Java plug-in'.

Method 2. Offline method for downloading and installing

http://www.java.com/en/download/help/windows_offline_download.xml

This process requires you to download an executable file that includes all the files needed for the complete installation. You do not need to remain connected to the Internet during the installation. The file can also be copied to a computer that is not connected to the Internet.

1. Go to the Manual download page
2. Click on Windows Offline.
3. The File Download dialog box appears prompting you to run or save the download file. Click Save to download the file to your local system.

Tip: Save the file to a known location on your computer, for example, to your desktop.

4. Close all applications including the browser.
5. Double-click on the saved file to start the installation process.
6. The installation process starts. Click the Install button to accept the license terms and to continue with the installation.



7. Oracle has partnered with companies that offer various products. The installer may present you with option to install these programs when you install Java. After ensuring that the desired programs are selected, click the Next button to continue the installation.



8. A few brief dialogs confirm the last steps of the installation process: click Close button on the last dialog.



9. This will complete Java installation process.

NOTE: You may need to restart (close and re-open) your browser to enable the java installation in your browser.

TECHNICAL SPECIFICATION

General	
Approvals	
CE – conforms to	EU Directive 89/336/EEC
FCC – verified to	CFR47: Part 15
Dimensions	
Satellite antenna unit	902mm(D) x 1039mm(H) (35.5" x 40.9")
Antenna dish diameter	650mm (25.6")
Antenna control unit	431mm x 380mm x 44mm (17" x 15" x 1.7")
Weight	
Satellite antenna unit	60 kg (132 lbs)
Antenna control unit	3.5 kg (7.7 lbs)
Antenna system performance	
Tx Frequency	13.75 ~ 14.5 GHz Ku-band
Tx Gain	37.7 dBi
Rx Frequency	10.7 ~ 12.75 GHz Ku-band
Rx Gain	36.3 dBi
Polarized Feed	Cross-pol only
Skew Control	Automatic Skew-angle Control
Azimuth range	Unlimited
Elevation range	-20° to +115°
Cross-level range	Up to ±37°
Stabilization Accuracy	0.2° peak mis-pointing @ max ship motion condition
Max Ship's motion	±25°roll, ±15° pitch, ±8°yaw@ 6 sec
Turning rate	Up to 12°/ sec & 5°/ sec ²
BUC	8W (Optional 4W, 16W)
Antenna Control Unit (VP-T520)	
Display	2 Line 40 Character Graphic VFD Module
Serial Interface	RS232C (57600 bps 8, N, 1)
Modem Interface	Ethernet port / RS-232C / I/O Console
Remote Access	RJ45, TCP/IP
Input Power	100 ~ 240V AC, 50 ~ 60Hz
Gyrocompass Interface	NMEA2000 / NMEA0183

ENVIRONMENTAL SPECIFICATION

Specification	Standards	
Temperature (Antenna)	Operational	-25°C to +55°C (IEC-60945)
	Survival	-40°C to +80°C (IEC-60945)
	Storage	-40°C to +85°C (IEC-60945)
Temperature (ACU)	Operational	-15°C to +55°C (IEC-60945)
	Survival	-25°C to +70°C (IEC-60945)
	Storage	-40°C to +85°C (IEC-60945)
Water Proofing	IPX6	
Salt Mist	Saline solution: 5 ±1 % NaCl Storage period: 7 Days (IEC-90654)	
Vibration	1. DNV Resonance Search (X, Y, Z axis) - 2 to 13.2Hz: Displacement 3mm - 13.2 to 50Hz: Acceleration 2.1g 2. DNV Resonance Durability (X, Y, Z axis) - 10Hz (Displacement 3mm): 90min (If no resonance fq) - Highest resonance frequency: 90 min (If Amp factor < 2) - All each resonance frequencies: 90 min (If Amp factor >= 2)	
Shock	Operational	IEC-60068-2-27 Method Ea 20g, 7 ms (6 each direction)
	Survival (Transient)	IEC-60721-3-6 Class 6M3 type II 30g, 6 ms (6 each direction)
	Survival (Bump)	IEC-60068-2-29 Method Eb 25g, 6 ms (100 each direction)

WARRANTY

This product is warranted by Intellian Technologies Inc., to be free from defects in materials and workmanship for a period of THREE (3) YEARS on parts and TWO (2) YEARS on labor performed at Intellian Technologies, Inc. service center from the purchased date of the product.

Intellian Technologies, Inc. warranty does not apply to product that has been damaged and subjected to accident, abuse, misuse, non-authorized modification, incorrect and/ or non-authorized service, or to a product on which the serial number has been altered, mutilated or removed.

It is required to present a copy of the purchase receipt issued by Intellian Technologies, Inc. that indicates the date of purchase for after-sales service under the warranty period. In case of failure to present the purchase receipt, the warranty period will begin 30 days after the manufacturing production date of the product purchased.

Any product which is proven to be defective in materials or workmanship, Intellian Technologies, Inc. will (at its sole option) repair or replace during the warranty period in accordance with this warranty. All products returned to Intellian Technologies, Inc. under the warranty period must be accompanied by a return material authorization (RMA) number issued by the dealer/distributor from Intellian Technologies, Inc. and a copy of the purchase receipt as a proof of purchased date, prior to shipment. Alternatively, you may bring the product to an authorized Intellian Technologies, Inc. dealer/distributor for repair.