

i2

Installation and Operation

User Manual

Document Number: 2012D0-UM1004-V1_0

Intellian Satellite TV Antenna Systems

Intellian i2 Serial Number

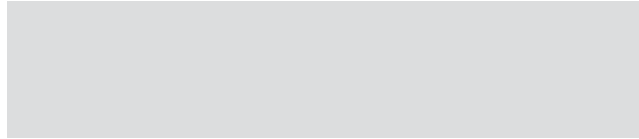

This serial number will be requested for all troubleshooting or service inquiries.

Notice All Right Reserved

Intellian i2® and Intellian® are the registered trademarks of Intellian Technologies, Inc., and should not be appropriated without permission by Intellian Technologies, Inc., and the information contained in this manual is the property of Intellian Technologies, Inc. Any and all parts of this manual shall not be reproduced and distributed in any form without prior written consent by Intellian Technologies, Inc. The information contained in this manual shall be subject to change at any time without notice due to the functional upgrade of the product.



INTRODUCTION	4	OPERATION USING PC CONTROLLER PROGRAM	49
INTRODUCTION TO INTELLIAN i2	4	INTRODUCTION	49
FEATURES OF INTELLIAN i2	5	PROGRAM INITIALING AND SERIAL PORT SETUP	50
BASIC SYSTEM CONFIGURATION OF INTELLIAN i2	6	MAIN MENU	51
		CONTROLLER MENUS	52
INSTALLATION	7	PREPARATION FOR TRANSPORTATION	61
SYSTEM COMPONENTS	7		
TOOLS REQUIRED FOR INSTALLATION	10	WARRANTY	62
PLANNING THE INSTALLATION	11		
INSTALLATION AND MOUNTING OF ANTENNA	14	APPENDIX : TECHNICAL SPECIFICATION	63
		INTELLIAN i2	64
INSTALLING THE ACU	17		
ACU DIMENSIONS	17		
SELECTING ACU INSTALLATION SITE	18		
CONNECTING THE SYSTEM CABLES	19		
CONNECTING THE SYSTEM TO A GPS	22		
ADJUSTING THE LNB SKEW ANGLE (LINEAR POLARIZATION ONLY)	23		
OPERATION INSTRUCTION	24		
INTRODUCTION	24		
OPERATING USING THE ACU	25		
ACU SOFT KEYS	25		
NORMAL MODE	25		
SETUP MODE	28		

Introduction

Introduction to Intellian i2

Intellian i2 is a digital satellite antenna system designed specifically for all types of vessels (Anchored or transit) to automatically identify, track and capture satellite signals from the Digital Video Broadcasting (DVB: the international standard for digital TV transmissions) compatible satellites.

Specifically, Intellian i2 has Wide Range Search (WRS) algorithm, which minimizes the search time during initialization, and Dynamic Beam Tilting (DBT) technology, which dynamically shapes the antenna beam to utilize stabilization. While tracking the target satellite, DBT technology uses a high-performance, constantly adjusting sub-reflector which allows the antenna to remain relatively still, eliminating the constant whine of stepper motors while staying locked onto the satellites.

For simplicity and savings, the i2 brings you hassle-free installation with its single cable design between the antenna and the control unit. For flexibility, there is a second RF connector on the antenna base. In addition, the i2 has adopted a built-in GPS interface (NMEA 0183,) allowing boaters to plug-in an external GPS to speed up acquisition time.



Features of Intellian i2

Enjoy satellite broadcasts at sea

Intellian i2 is the most modern antenna system that enables you to receive high quality broadcasting signals at sea where the atmospheric and environmental conditions are very harsh.

Fully automatic control system

The fully automatic control system allows you to simply turn the power switch on, and have crystal clear, high quality satellite television in motion or at anchor.

High quality antenna

High tech parabolic antenna technology has been adopted for this antenna system, which is optimal for marine conditions. This enables you to receive the optimal signal level even when it is raining or snowing.

Fast and efficient search for the satellite

The WRS (Wide Range Search) algorithm allows for the antenna system to search the satellite within the shortest amount of time and to detect the satellite signal under any position and within any directional movement of the ship.

Outstanding reliability

Intellian i2 provides highly reliable system through the implementation of a modularized design and the usage of strictly proven components.

Easy installation

Intellian i2 uses only one RF cable for installation. This makes installation easy. Power, RF, and Data signals transfer from the antenna to the ACU through this single cable.

Compact size

Intellian i2's small and compact size is perfect for small vessels.

Intellian Satellite TV Antenna Systems

Basic System Configuration of Intellian i2

For your satellite TV system to function properly, the system will have to be connected with all of the provided components as shown on the right (Refer to the next chapter 'Installation' in this manual for more detailed connection instructions). Separate purchase of a satellite receiver and a TV is required.

Note: Dish Network and Bell TV users please refer to the Intellian Dish Network MIM Installation and User Manual.

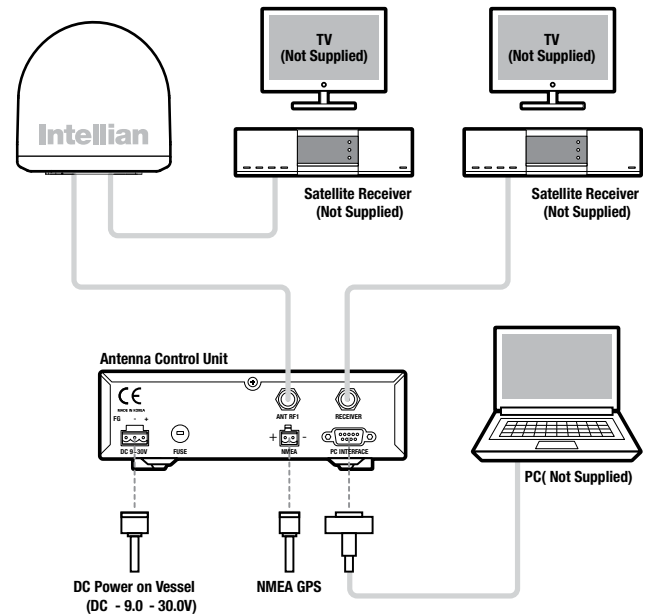

Figure 01 : Basic Configuration with 2 Receivers

Installation

The components of the Intellian i2 have been designed to be modular so that it is suitable for simple installation on all types of vessels.

System Components

Antenna Unit

The antenna of Intellian i2 is comprised with the following components for optimum search and reception of the satellite signal.

- Mechanical Unit – manipulates the antenna to receive an optimal satellite signal regardless of the movement of the vessel.
- Control Unit – controls mechanical operation of the antenna.
- RF Unit – transmits an optimum satellite signal to the receiver.
- Radome – protects the antenna from severe marine environmenta



Figure 02 : Radome

Intellian Satellite TV Antenna Systems

Antenna Control Unit (ACU)

The Antenna Control Unit (ACU) provides the power to the antenna and controls various settings of the antenna. The digital VFD (Vacuum Fluorescent Display) allows for easy operation of the ACU, even in the dark.

The functions of the ACU are as follows:

- Provides power to the antenna unit
- Monitors the antenna status
- Changes the target satellite
- Set up the user environment
- Set the current GPS information
- Set satellite information
- Perform self-diagnosis of the antenna
- Set up the interface with a PC

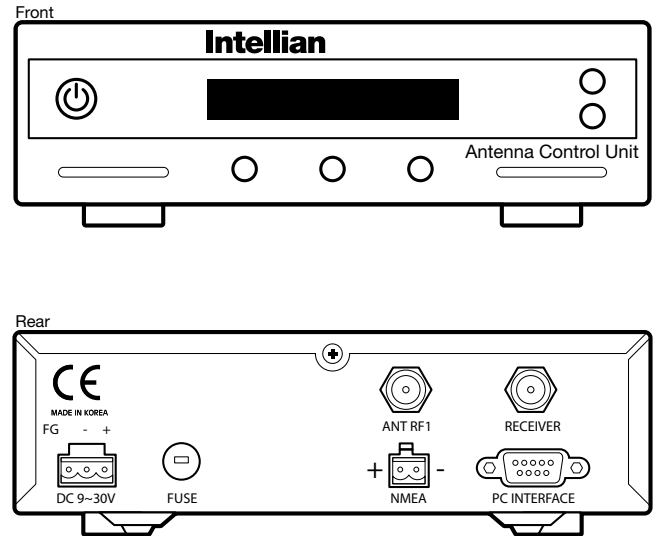

Figure 03 : Front & Rear of ACU

Installation Kit

Contains the items required for securing the antenna unit and ACU to the vessel.







Antenna				
Item				
	Hex.Bolt	Flat Washer	Spring Washer	Hex. Nut
Qty	5	5	5	5
ACU				
Item				
	Self-Tapping Screw	Machine Screw		
Qty	5	5		
Size	(M4 X 16L)	(M3 X 8L)		

Figure 04 : Installation Bolt Kit

Other Components

No	Components	Size	Qty
1	ACU Bracket	-	2
2	RG6(Antenna – ACU RF Cable)	15m	1
3	RG6(ACU – IRD Cable)	3m	1
4	Power Cable	10m	1
5	PC Serial Cable	1.8m	1
6	NMEA Connector	1.5m	1
7	Power Connector	AK950-2	1
	Hex Bolt	M6x35L	5
		M6x50L	5
8	Tapping Screw	ø4x16L	5
		ø3x8L	5
	Flat Washer	M6	10
	Spring Washer	M6	5
	Nut	M6	5
9	Installation CD	-	1
10	User Manual	-	1
11	Mounting Template		1
12	Quick Installation Guide	-	1

Figure 05 : List of the Supplied Parts

Tools Required for Installation

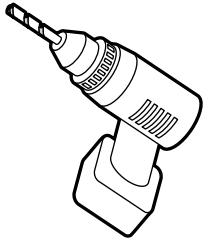

Power Drill

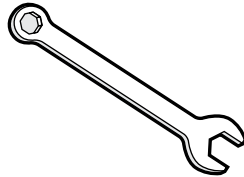

11 mm Spanner

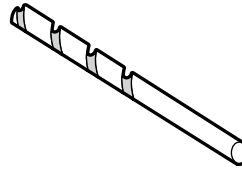

8 mm Drill Bit

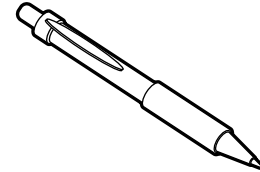

Pencil

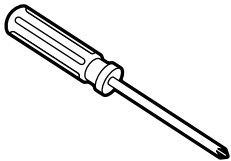

**Cross-Head
Screwdriver**

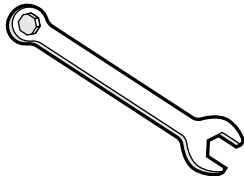

10 mm Spanner



**Ø50 mm
Hole Saw**

Figure 06 : Required Tools for Installation

Planning the Installation

Selection of Installation Site

Install the antenna in accordance with the following procedures to ensure maximum performance of the antenna.

The antenna should be installed in a place where it has an all-round clear view of the horizon. Please be sure there are no obstacles within 15 degrees above the antenna. Any obstacles can prevent the antenna from tracking the satellite's signal (Refer to the drawing on the right).

Do not install the antenna nearby the radar, especially if their on the same plane, as their energy levels may overload the antenna's front-end circuits. It is recommended to position the antenna at least 4 feet (1.2m) above or below the level of the radar and a minimum of 15 feet (4.6m) away from any high power short wave radars.

The mounting platform should be rigid enough and not subjected to excessive vibration. The movement of the antenna can be minimized by installing it at the center of the vessel. For optimal performance of the antenna, it is not recommended to install it at any corner of the vessel, where the movement of the vessel is the greatest. Install the bottom of the antenna parallel to the surface of the sea and fix it tightly to the structure of the vessel.

When setting the antenna down, be careful not to damage the RF connector. Striking the connectors on the bottom directly will damage the connector.

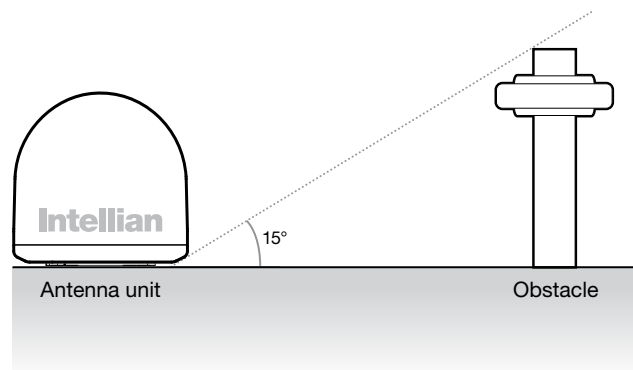

Figure 07 : Elevation Limit of Obstacles

Intellian Satellite TV Antenna Systems

Cables

Before installing the system's cables, consider the following points.

- All cables need to be well clamped and protected from physical damage and exposure to heat and humidity.
- A cable with an acute bend is not allowed.
- Where a cable passes through an exposed bulkhead or deckhead, a watertight gland or swan neck tube should be used.

Power Requirements

You need to follow the power requirements to avoid damaging the system.

- Intellian i2 has been designed to work on a boat's power supply rated at 12V / 24V DC (acceptable range: 9~30 V DC).
- If your IRD(s) and television(s) require a 110V/240V AC power supply, you will need to install a suitable DC to AC converter to operate the unit(s) from your boat's DC power supply.

Extending the cables

The cables that have been supplied with your Intellian system should be of adequate length to complete the installation on most boats.

Power Cable

This cable is supplied at a length of 10m.

RF Cable

This cable is supplied at a length of 15m. If a longer length is required you should replace this cable with an extended RF cable supplied by Intellian Technologies.

Note: Exceeding the indicated cable lengths will result in reduced performance of your system.

Installation and Mounting of the Antenna

The method of installation and mounting of antenna may vary due to vessel design but the following procedures are applicable in most situations, and will result in a secure and effective installation.

Confirmation of Size and Installation of Power Tower

- Confirm the height and diameter of the bottom surface of the antenna before installing it.
- The space must be sufficient for installing the antenna unit considering the height and diameter of the antenna.
- The height and the diameter of the bottom surface of the antenna are as shown in the following drawing. If possible, install the antenna using a power tower.

Note: Before installing the antenna, open the radome and remove the shipping constraints from the antenna interior. Reinstall the radome before operating the system. The system will not perform properly if the radome is open.

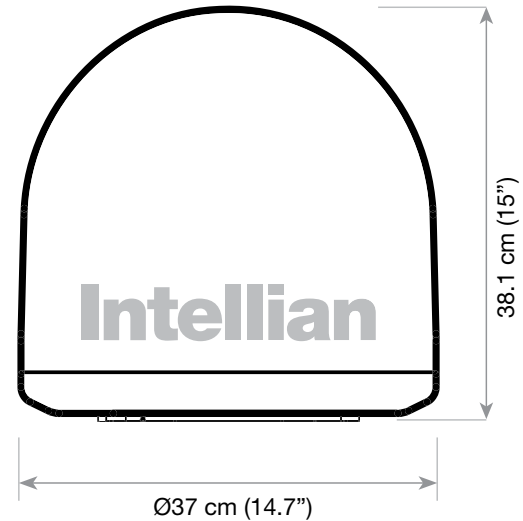

Figure 08 : Radome Dimension of i2

Intellian Satellite TV Antenna Systems

Marking of the Antenna's Parking Position

Referring to the Mounting template, mark where antenna is to be mounted onboard the ship (it must be a flat surface) or on a separate power tower by drawing a square of 14.4cm (5.7")

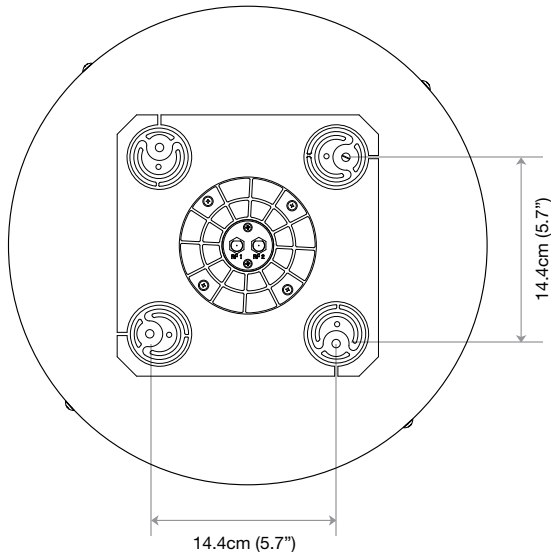

Figure 09 : Intellian i2

Note: If a power tower is not used to mount the antenna, separate cable shocks and waterproofing measures must be taken to protect the RF connector from being exposed to sea water and external shocks. An exposed cable may cause electric shock and cause serious damage to the equipment.

Securing Holes for Bolts and Cable Ways

Make 4 bolt holes of 8mm diameter, one at each corner of a rectangle drawn as below, and make a circular hole of 50mm diameter at the center of the rectangle through which the cable will run.

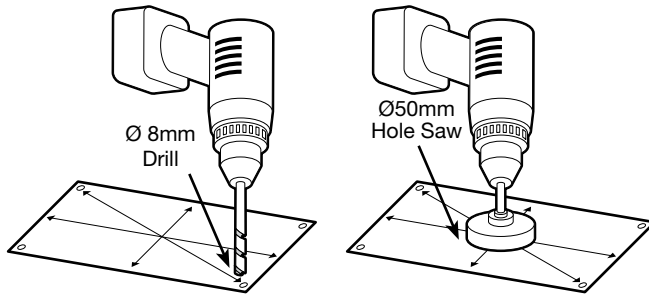

Figure 10 : Drilling Instruction

Connection of the Cable

Remove the rubber cap from RF connector. Connect the RF cable to the RF connector under the base plate through the access hole using an 11mm spanner. Be careful not to over tighten, as you may damage the connector.

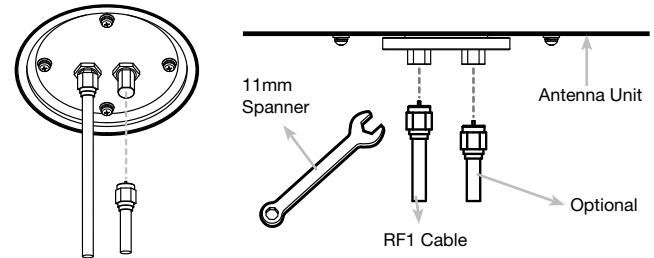

Figure 11 : Connectors on Bottom of Antenna

Note: Do not use excessive force when using the spanner, this will damage the threads. Be careful that the connectors do not contact the mounting surface of the antenna, this may cause critical malfunction and serious damage to the equipment.

Mounting the Antenna

Fix the antenna to the holes made before as shown in the drawing below by using the hex head bolts (M6 X 35L), M6 spring washer, M6 flat washer and M6 Nut supplied.

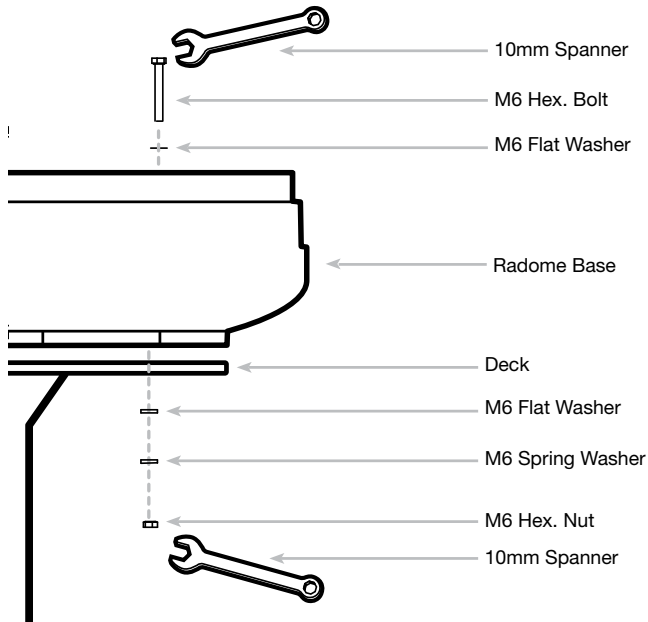

Figure 12 : Mounting the Antenna

Installing the ACU

ACU Dimensions

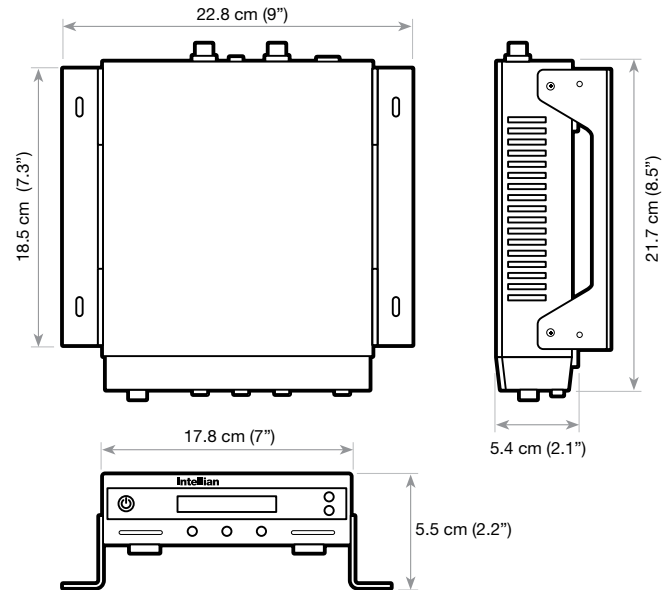

Figure 13 : Dimension of ACU

Selecting ACU Installation Site

The ACU should be installed below deck, in a location that is:

- Dry, cool, and ventilated.
- Easily accessible from your main TV viewing area.

To Install the ACU

1. The ACU should be installed using the two supplied mounting brackets which allow for a top or bottom mounting configuration.
2. Using the self tapping screws supplied, attach the mounting brackets to the sides of the ACU.
3. Place the ACU in the location where it is going to be installed.
4. Connect the cables to the rear of the ACU.
5. Use a pencil to mark the 4 hole positions (two on each side), and use the appropriate drill bit to drill them.

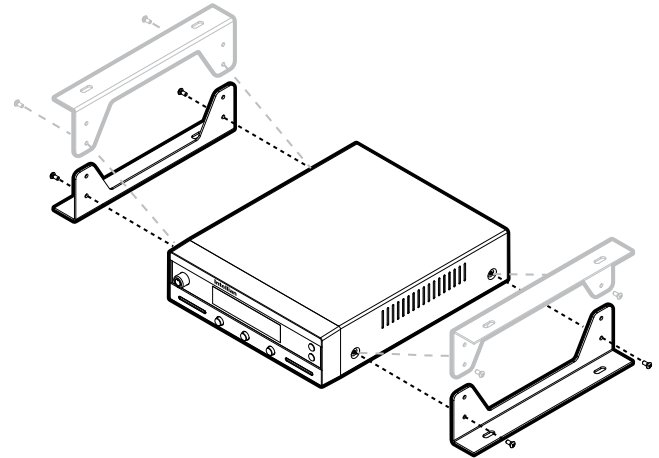

Figure 14 : Installation of ACU

Connecting the System Cables

After installation and fixation of the antenna, connect the ACU to the antenna. Refer to the drawing below to connect cables.

Single IRD Connection

- Connect the RF Cable (15m) from the RF 1 connector on the antenna to the ANT. RF1 connector on the rear of ACU.
- Connect the ACU-IRD Cable (3m) from the RECEIVER connector on the rear of the ACU to the RF on the IRD.
- Connect the power cable (10m) from the DC power connector on the rear of ACU to a power source at 12V /24V DC.
- Press the POWER ON switch in front of the ACU to start operating the antenna system automatically.

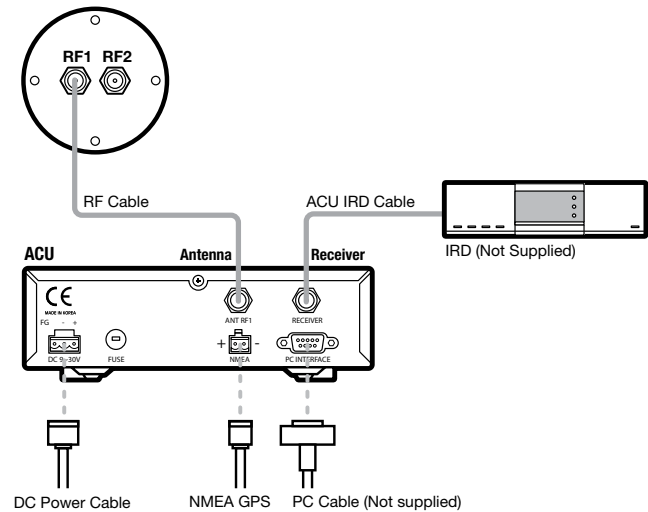

Figure 15 : Single IRD Configuration

Twin IRDs Connection

You can connect two IRDs for your antenna as shown in the following diagram. One of the IRD's need to be set up with the ACU in order to use another IRD without connecting the ACU. Both IRD's with and without an ACU connection can receive any channels that are available from the tracked satellite.

As in the single IRD option, the RF cables from the antenna base plate should be connected to 'LNB', 'ANT', or 'Satellite In' on the rear panel of the IRD.

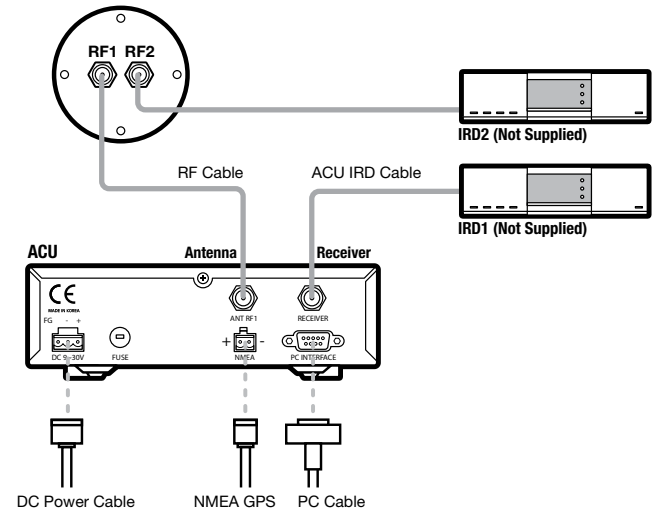

Figure 16 : Dual-IRDs Configuration

Intellian Satellite TV Antenna Systems

Multiple-IRDs Connection

In order to connect multi-IRD to the antenna, you will need to purchase a suitable multiswitch. The multiswitch has to be installed between the antenna unit and the IRDs as shown on the right.

Note: The system can receive either “High Band” or “Low Band” channels by using a multi-switch to connect more than two receivers.

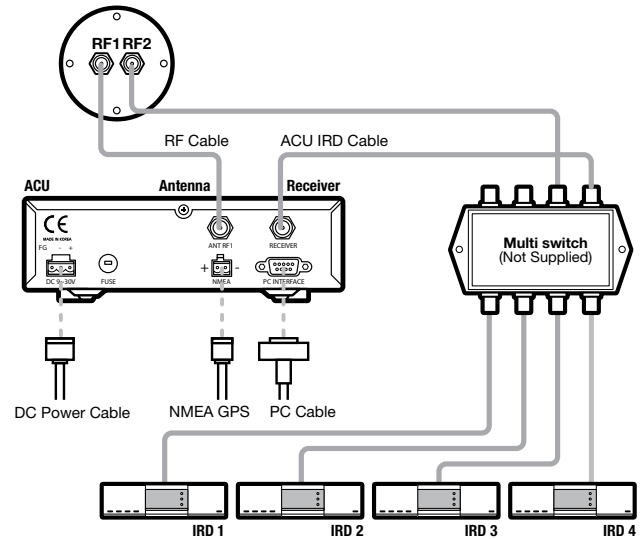

* IRD 1~4 : Not supplied

Figure 17 : Multi-IRDs Configuration

Connecting the System to a GPS

To improve satellite tracking, you can connect your satellite TV system directly to your boat's NMEA 0183 GPS system. To do this you will need a cable with suitable lengths to connect to your GPS system and you will need the green 2-way ACU GPS connector supplied with your Intellian i1/i2 Satellite TV System.

To connect the system to a GPS

1. Remove the rubber band insulations on each cable and connect a cable to each terminal of the 2-way connector.
2. Tighten the locking screws.
3. Connect the cable from the **+ve** (positive) terminal of the ACU's GPS connector to the NMEA **OUT** wire of the boat's GPS system.
4. Connect the cable from the **-ve** (negative) terminal of the ACU GPS connector to the **ground wire** of the boat's GPS system.
5. Refit the ACU GPS connector to the rear of the ACU.

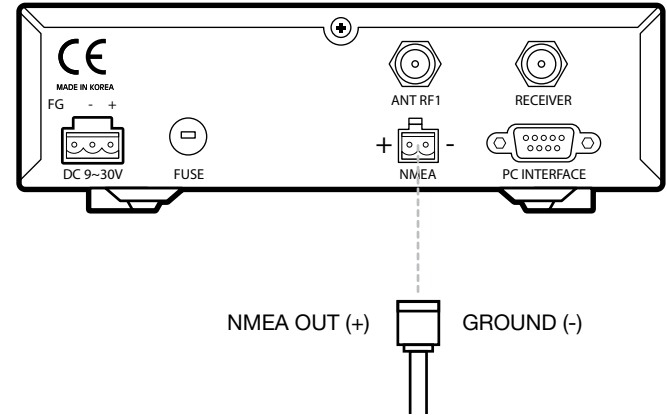

Figure 18 : NMEA 0183 GPS Connection

Adjusting the LNB Skew Angle (Linear Polarization Only)

LNB Skew Angle

The LNB skew angle only needs to be adjusted when the target satellite is linear polarized. In order to receive the maximum satellite signal level, the LNB skew angle must be adjusted according to the calculation of current GPS location and target satellite.

It only needs to be adjusted when changing from one satellite to another, or when the vessel has traveled a significant geographic distance. It should NOT need to be readjusted if the vessel stays in the same location and is operating on the same satellite.

Skew Angle Adjustment for i2

Polarization of your Intellian i2 antenna must be accomplished manually by the following steps.

- Remove the upper part of the Radome after switching the power OFF.
- Loosen the 3 screws that connect the LNB to the feed horn.
- Turn the LNB to place it to the angle indicated on the back of the feed horn.
- Tighten the 3 screws.

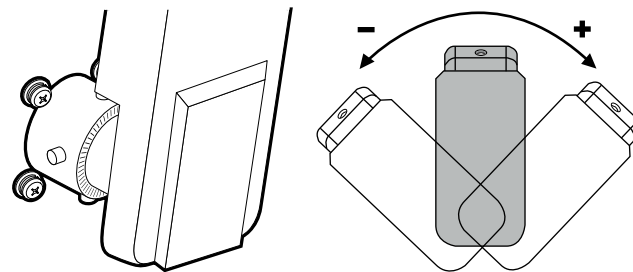

Figure 19 : Manual Angle Adjustment LNB Skew

Operation Instruction

Introduction

This section of the handbook describes how to setup your Satellite TV System after installing the ACU. It includes the following functions:

- System start up.
- Changing the default satellite.
- Monitoring the antenna status.
- Setting sleep mode.
- Entering setup mode.
- Setting the satellite pair.
- Editing satellite information.
- Setting the antenna parameter.
- Setting the LNB local frequency.
- Setting GPS.
- Setting the DiSEqC method.
- Display versions.
- Display power status.
- Setting antenna go position.
- Setting antenna move step.
- Setting remote control.
- Setting the factory default parameters.
- Performing diagnostic tests.

Note: Many of the above functions will only be required only after initial installation of your system. Refer to the Quick Installation Guide before operating the system.

Operation Using the ACU

ACU Soft Keys

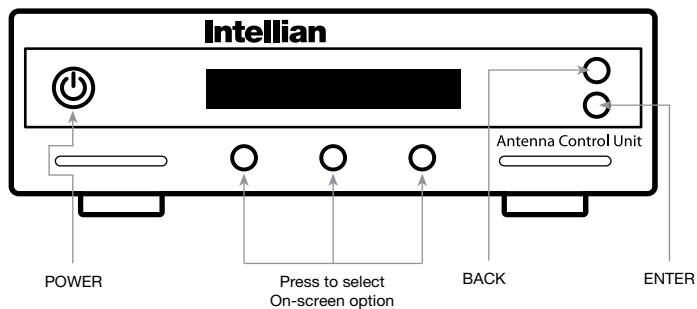
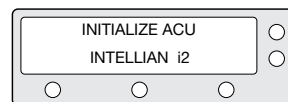

Figure 20 : ACU Soft Keys

Normal Mode

Start Up

With the system installed and power applied, the ACU screen will show the following sequence:



1. Data communication is being established between the antenna and the ACU. The ACU is initialized.

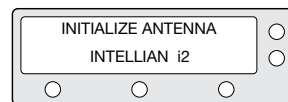

2. The antenna is initialized.

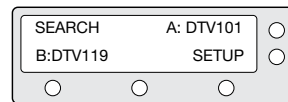

3. The antenna is searching for Satellite A.

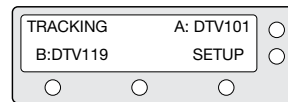

4. The antenna has located the satellite and is now tracking.

Changing Target Satellite

Your antenna is programmed with two candidates for target satellites as the default Dual-sat mode. Use advanced Tri-sat mode for targeting three satellites. To change the target satellite, press the LEFT soft key. The target satellite is changed and is automatically tracked by the antenna.

Default Dual-Sat Mode

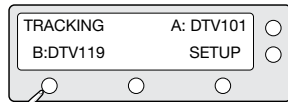

1. Press LEFT soft key for tracking Satellite B.

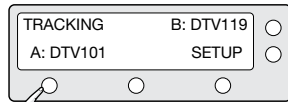

2. The antenna is tracking Satellite B.

Advanced Tri-Sat Mode

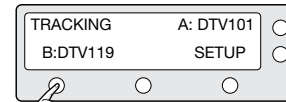

1. Press LEFT soft key for tracking Satellite B.

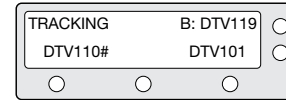

2. The antenna is tracking Satellite B.

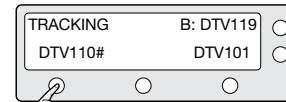

3. Press LEFT soft key for tracking Satellite C.

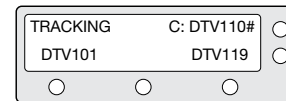

4. The antenna is tracking Satellite C.

Intellian Satellite TV Antenna Systems

Monitoring the Current Status of the Antenna

While the power is ON on the Intellian i2, ACU displays the status of the antenna. The various ACU displays may be shown according to the current status of the antenna.

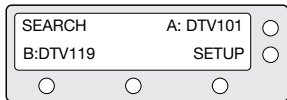

1. The antenna is searching Satellite A.

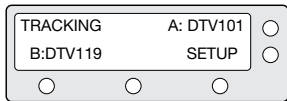

2. The antenna is tracking Satellite A.

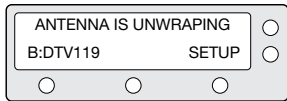

3. The antenna is winding/unwinding the cables in the antenna.

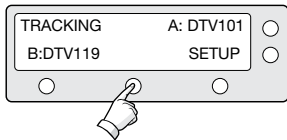

4. The antenna is again tracking Satellite A.
A. Press center soft key to display position detail.



5. Antenna position detail and signal strength are displayed.

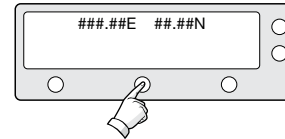

6. Press center soft key to display current GPS information.

Sleep Mode

If the antenna loses the tracking satellite while in sleep mode, sleep mode will be cancelled.

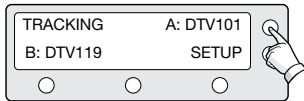

1. Press BACK to enter sleep mode.

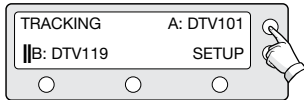

2. Press BACK again for exiting sleep mode.

Setup Mode

Begin Setup Mode

To enter the Setup Mode simply follow the instructions below.

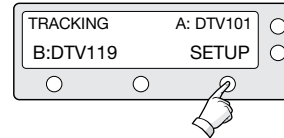

1. With the antenna is tracking, press SETUP.

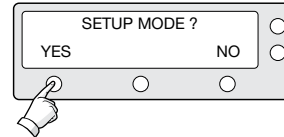

2. Press YES to enter setup mode.

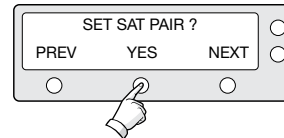

3. Press YES to set the satellite pair.

Intellian Satellite TV Antenna Systems

Setting the Satellite Pair

You can change the satellite pair if you decide to receive satellite television service from a different service provider.

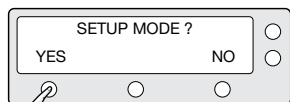

1. Press YES to enter setup mode.

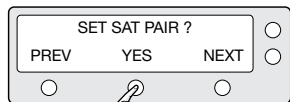

2. Press YES to set satellite pair.

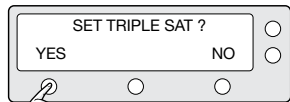

3. Press YES to set triple satellites.

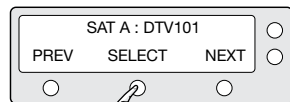

4. Set satellite A
Press PREV to show previous satellite name.
Press SELECT to set chosen satellite to SAT A.
Press NEXT to show next satellite name.

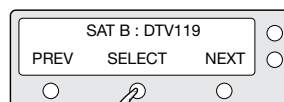

5. Set satellite B
Press PREV to show previous satellite name.
Press SELECT to set chosen satellite to SAT B.
Press NEXT to show next satellite name.

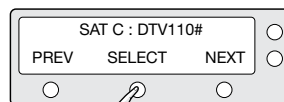

6. Set satellite C
Press PREV to show previous satellite name.
Press SELECT to set chosen satellite to SAT C.
Press NEXT to show next satellite name.

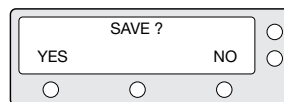

7. Press YES to save selections.
Press NO to cancel and return to main setup mode.

Setting GPS

It is possible to set up and modify the GPS information, which enhances the antenna functionality.

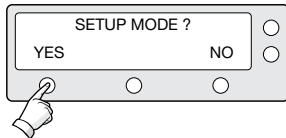

1. Press YES to enter setup mode.

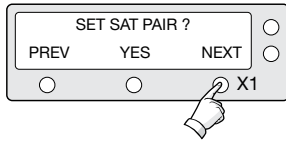

2. Press NEXT to enter GPS setup mode.

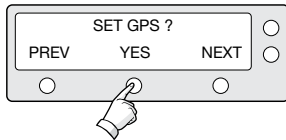

3. Press YES to set GPS.

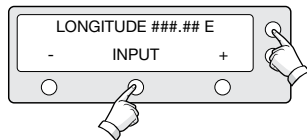

4. Input the longitude data.
+ increases the value. - decreases the value.
Change the underscored digit using the +/- buttons.
Press INPUT to accept the value and move to next digit. Press BACK to move to previous digit.

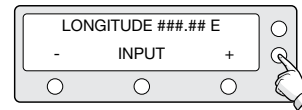

5. Press ENTER to move to next screen.
Press BACK to move to previous screen.

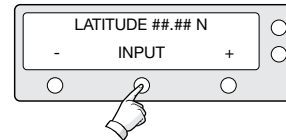

6. Input the latitude data.
+ increases the value. - decreases the value.
Change the underscored digit using the +/- buttons.
Press INPUT to accept the value and move to next digit.
Press BACK to move to previous digit.

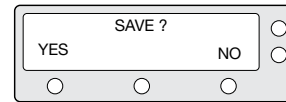

7. Press YES to accept data.
Press NO to cancel and return to main setup mode.

Intellian Satellite TV Antenna Systems

Edit Satellite Information

It is possible to modify the existing satellite information and input new satellite information into the ACU as well. It is not recommended for a novice satellite service user to use this mode.

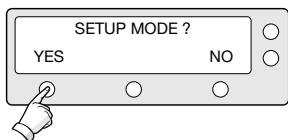

1. Press YES to enter setup mode.

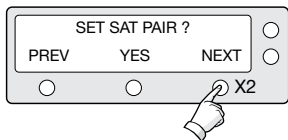

2. Press NEXT twice to enter edit satellite info mode.

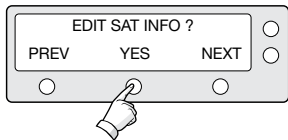

3. Press YES to edit satellite info.

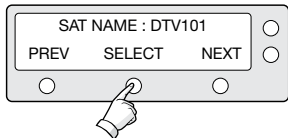

4. Set the satellite name.
PREV - Shows previous satellite name.
SELECT - Select the displayed satellite for editing.
NEXT - Shows next satellite name.
Press ENTER to move to next screen.

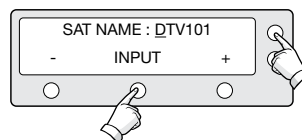

5. Input the satellite name.
+ increases the value. - decreases the value.
Change the underscored digit using the +/- buttons.
Press INPUT to accept the value and move to next digit.
Press BACK to move to previous digit.

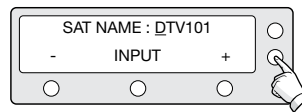

6. Press ENTER to move to next screen.
Press BACK to return previous screen.

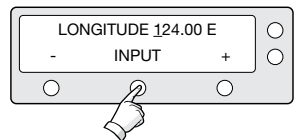

7. Input the satellite position.
+ increases the value. - decreases the value.
Change the underscored digit using the +/- buttons.
Press INPUT to accept the value and move to next digit.
Press BACK to move to previous digit.

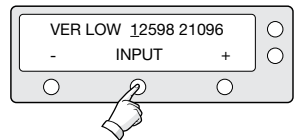

8. Input the tracking frequency (MHz) and symbol rate (KHz) for vertical low band.

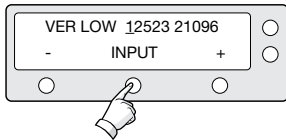

9. Input the network ID (NID) for vertical low band.

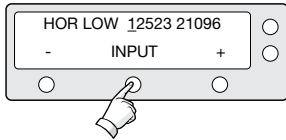

10. Input the tracking frequency (MHz) and symbol rate (KHz) for horizontal low band.

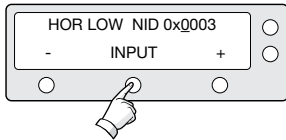

11. Input the network ID (NID) for horizontal low band.

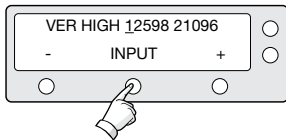

12. Input the tracking frequency (MHz) and symbol rate (KHz) for vertical high band.

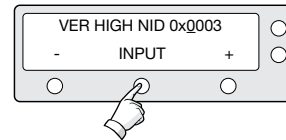

13. Input the network ID (NID) for vertical high band.

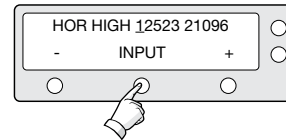

14. Input the tracking frequency (MHz) and symbol rate (KHz) for horizontal high band.

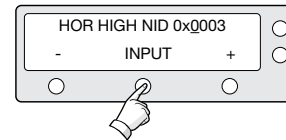

15. Input the network ID (NID) for horizontal high band.

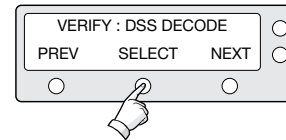

16. Select the **Verification Method*** of tracking satellite.
PREV - Shows previous method.
SELECT - Set the displayed method.
NEXT - Shows next method.

Intellian Satellite TV Antenna Systems

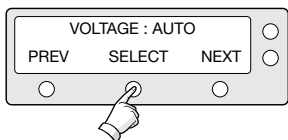

17. Select the **Voltage Supply Method*** to LNB.
(AUTO is recommended)

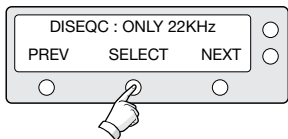

18. Select the **DISEQC Method***.
(AUTO is recommended)



19. Press YES to save the input information.
Press NO to cancel and return to main setup mode.

Verification Method*

SIGNAL - use only signal level for tracking
DVB LOCK - use only DVB Lock signal for tracking
DVB DECODE - verify satellite using DVB decoding method for tracking
DSS DECODE - decode only DSS Lock signal for tracking
AGC AFTER DECODE - for tracking Ka-Band satellite

Voltage Supply Method*

AUTO – Supply 13V or 18V to LNB
ONLY 13 V - always supply 13 V to LNB
ONLY 18 V - always supply 18 V to LNB

DISEQC Method*

AUTO – Supply 0KHz tone or 22KHz tone to LNB
ONLY 0 KHz – always supply 0KHz tone to LNB
ONLY 22 KHz – always supply 22KHz tone to LNB

Setting the Antenna Parameters

It is not recommended for a novice satellite service user to use this mode. Consult Intellian for changing antenna parameters.

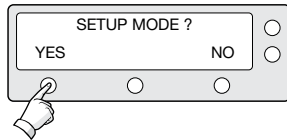

1. Press YES to enter setup mode.

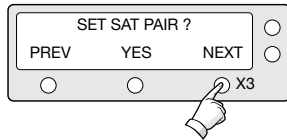

2. Press NEXT three times to enter set antenna parameter mode.

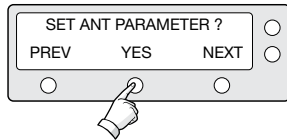

3. Press YES to set antenna parameter.

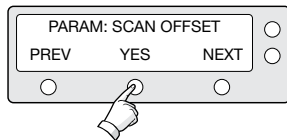

4. Select the **PARAM***.
PREV - Shows previous parameter.
SELECT - Set the displayed parameter.
NEXT - Shows next parameter.
Press ENTER to move to next screen.

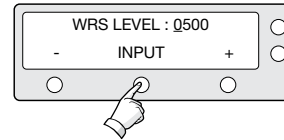

5. Input the WRS LEVEL.
+ increases the value. - decreases the value.
Change the underscored digit using the +/- buttons.
Press INPUT to accept the value and move to next digit.
Press BACK to move to previous digit.
Press ENTER to move to next screen.

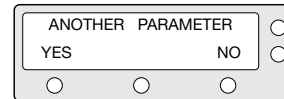

6. Press YES to set up another parameter.
Press NO to cancel and return to main setup mode.



7. Press YES to save the input information.
Press NO to cancel and return to main setup mode.

Intellian Satellite TV Antenna Systems

PARAM*

Scan Offset	The scan offset is to offset the angle difference between the black marker on the sub-reflector and the optical sensor.	DiSEqC Level	The DiSEqC level is to distinguish 0KHz tone and 22KHz tone.
Track Scale	The track scale is to control the tracking speed while antenna is tracking the satellite.	Offset RH-LH	The offset RH-LH is to offset the signal difference between RHCP and LHCP.
Detect Level	The detect level is to set the satellite signal detection level.	EL Offset	The EL offset is to offset the angle difference between the mechanical elevation angle and actual elevation angle.
WRS Level	The WRS level is to set the WRS detection level.	Use WRS	Use WRS is to determine whether the system uses WRS level or not. "Use WRS" and "WRS Level" are pair functions.
Track Offset	The tracking offset is to offset the satellite signal tracking level.	Offset Difference	Offset difference is to determine whether the system to uses "Offset RH-LH" or not. "Offset Difference" and "Offset RH-LH" are pair functions.
Power Level	The power level is to distinguish the voltage between 13 V and 18 V.		

Setting the LNB Local Frequency

It is possible to select a local frequency from ACU. It is not recommended for a novice satellite service user to use this mode.

Case1. Single band LNB is used.

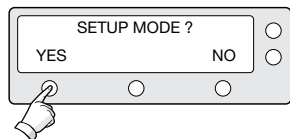

1. Press YES to enter setup mode.

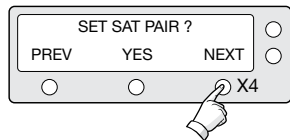

2. Press NEXT four times to enter set local frequency mode.

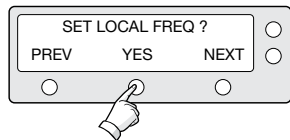

3. Press YES to set local frequency.

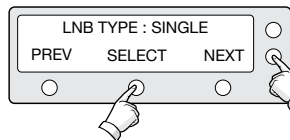

4. Select the **LNB Type*** - SINGLE.
PREV - Shows previous LNB type.
SELECT - Set the displayed LNB type.
NEXT - Shows next LNB type.
Press ENTER to move to next screen.

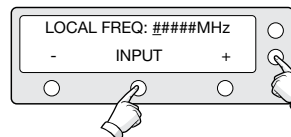

5. Input the local frequency of LNB.
+ increases the value. - decreases the value.
Change the underscored digit using the +/--buttons.
Press INPUT to accept the value and move to next digit.
Press BACK to move to previous digit.
Press ENTER to move to next screen.



6. Press YES to accept the data.
Press NO to cancel and return to main setup mode.

Intellian Satellite TV Antenna Systems

Case 2. Universal LNB is used (Low band local frequency-9750 MHz/ High band local frequency 10600 MHz).

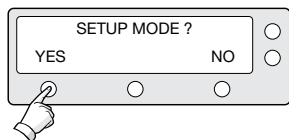

1. Press YES to enter setup mode.

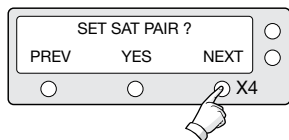

2. Press NEXT four times to enter set local frequency mode.

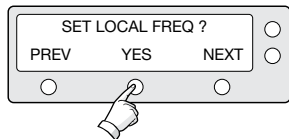

3. Press YES to set local frequency.

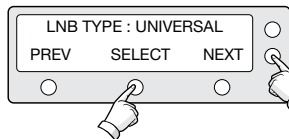

4. Select the **LNB Type*** - UNIVERSAL.
PREV - Shows previous LNB type.
SELECT - Set the displayed LNB type.
NEXT - Shows next LNB type.
Press ENTER to move to next screen.



5. Press YES to accept the data.
Press NO to cancel and return to main setup mode.

LNB Type*

SINGLE: Single Band LNB

Asia 11300 MHz, Japan 10678 MHz, Korea 10750 MHz,
America 11250 MHz

UNIVERSAL : Universal LNB

Low band local frequency - 9750 MHz

High band local frequency - 10600 MHz

Setting the DiSEqC Method

DiSEqC selection can be made from ACU. It is not recommended for a novice satellite service user this mode.

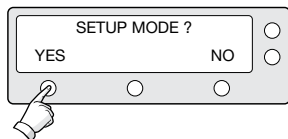

1. Press YES to enter setup mode.

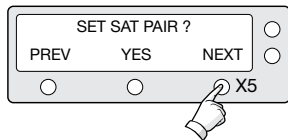

2. Press NEXT five times to enter DISEQC mode.

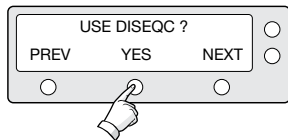

3. Press YES to use DISEQC.



4. Select the **DiSEqC Method***
PREV - Shows previous DiSEqC Method.
SELECT/ENTER - Set the displayed DiSEqC method.
NEXT - Shows next DiSEqC Method.
Press ENTER to move to next screen.

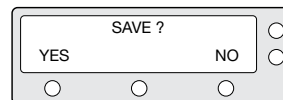

5. Press YES to accept the selection.
Press NO to cancel and return to main setup mode.

DiSEqC Method*

DO NOT USE DISEQC - DiSEqC is not being used.

USE TO CHANGE BAND - DiSEqC is being used to change to low and high band.

USE TO CHANGE SAT - DiSEqC is being used to change tracking satellite.

Intellian Satellite TV Antenna Systems

Display Versions

This sequence enables you to see what version of antenna and ACU software are installed on your system.

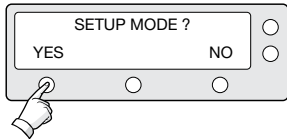

1. Press YES to enter Display Version.

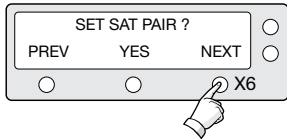

2. Press NEXT six times to enter view version mode.

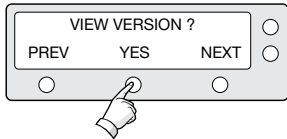

3. Press YES to view version.

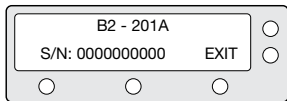

4. Antenna product name and S/N are shown.
Press EXIT to return to main setup mode.

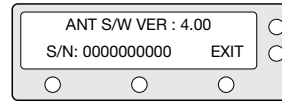

5. Antenna software version and S/N are shown.
Press EXIT to return to main setup mode.

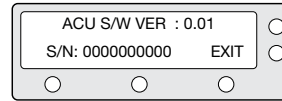

6. ACU software version and S/N are shown.
Press EXIT to return to main setup mode.

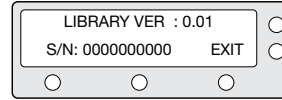

7. Library version and S/N are shown.
Press EXIT to return to main setup mode.

Display Power

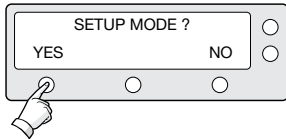

1. Press YES to enter setup mode.

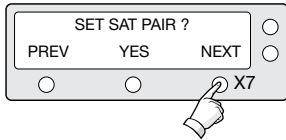

2. Press NEXT seven times to enter view power mode.

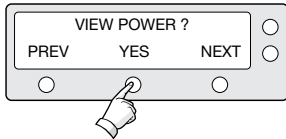

3. Press YES to view power.

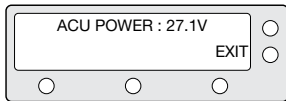

4. ACU input voltage is shown.
ACU output voltage is shown.
Press any key to return to main setup mode.

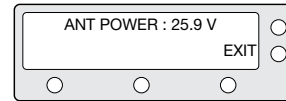

5. Antenna input voltage is shown.
Press center soft key to view IRD Voltage and frequency.
Press EXIT to return to main setup mode.

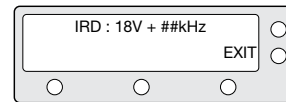

6. IRD voltage and frequency are shown.
Press EXIT to return to main setup mode.

Intellian Satellite TV Antenna Systems

Setting Remote Control

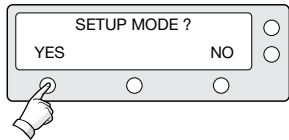

1. Press YES to enter setup mode.

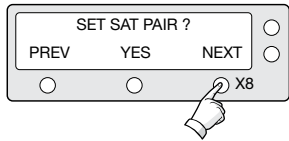

2. Press NEXT eight times to enter remote control setting mode .

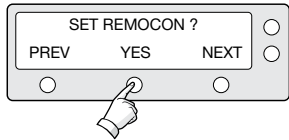

3. Press YES to set remote control.

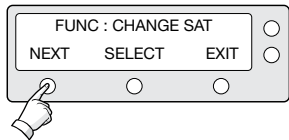

4. Select the **Function***
NEXT - Shows next function.

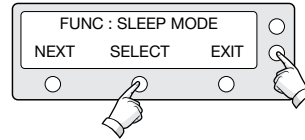

5. SELECT/ENTER - Registers a key on remote control.



6. Point remote control to ACU.
Press any key on remote control for selected function and press the same key again for confirmation. Press BACK to move to previous screen.
Press EXIT to return to main setup mode.

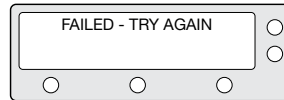

7. If failed to press the same key twice, TRY AGAIN will be displayed.

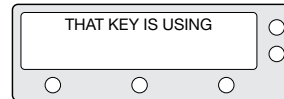

8. If failed to register a free key, KEY IS USING will be displayed.



9. REMOTE KEY REGISTERED will be displayed if key has been properly registered.

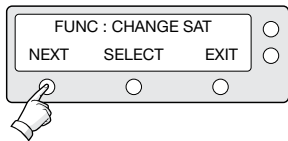

10. Press NEXT to shows next function.
Press EXIT to return to main setup mode.

Function*

CHANGE SAT - Change the target satellite.

SLEEP MODE - Enter sleep mode.

CLEAR REGISTERED KEY - Clear registered key.

Intellian Satellite TV Antenna Systems

Setting Antenna Go Position

The antenna can be controlled manually by using the ACU.

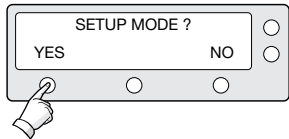

1. Press YES to enter setup mode.

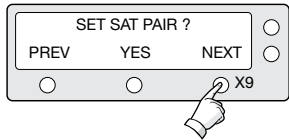

2. Press NEXT nine times to enter antenna go position mode.

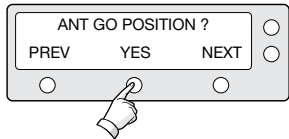

3. Press YES to go position.

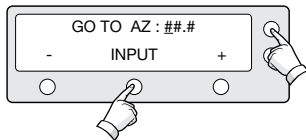

4. Input position value for azimuth (AZ) axis.
+increases the value. - decreases the value.
Change the underscored digit using the +/- buttons.
Press INPUT to accept the value and move to next digit.
Press BACK to move to previous digit.
Press ENTER to move to next screen.

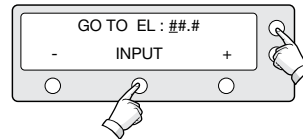

5. Input position value for elevation (EL) axis.
+ increases the value. - decreases the value.
Change the underscored digit using the +/- buttons.
Press INPUT to accept the value and move to next digit.
Press BACK to move to previous digit.
Press ENTER to move to next screen.

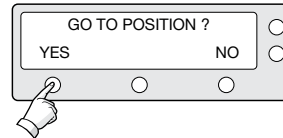

6. Press YES to move the antenna to input position.
Press NO to return to the Antenna Go Position mode.

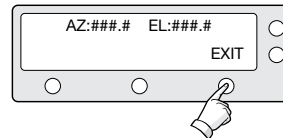

7. Press EXIT to return to main setup mode.

Setting the Antenna Move Step

The antenna can be moved by 1° step manually by using ACU.

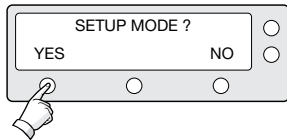

1. Press YES to enter setup mode.

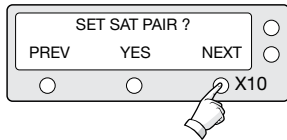

2. Press NEXT ten times to enter antenna move step mode.

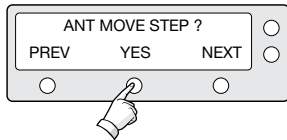

3. Press YES to move step.

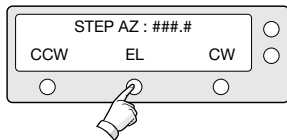

4. Move the antenna in the AZ axis.
CW - Move the antenna clockwise.
CCW - Move the antenna counter clockwise.
EL - Go to elevation control screen.

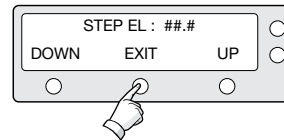

5. Move the antenna in the EL axis.
UP - Move the antenna up.
DOWN - Move the antenna down.
EXIT - Return to antenna move step mode.

Intellian Satellite TV Antenna Systems

Executing Antenna Diagnosis

It is possible to see the antenna's status by reviewing the results of diagnosis of the antenna. Refer to the following codes to understand the diagnosis results.

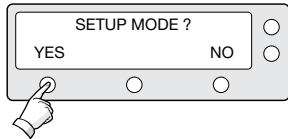

1. Press YES to enter setup mode.

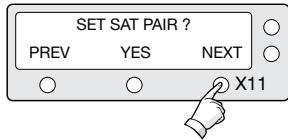

2. Press NEXT eleven times to enter antenna diagnosis mode.

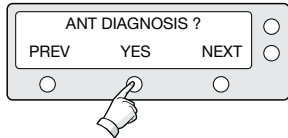

3. Press YES to diagnose the antenna.

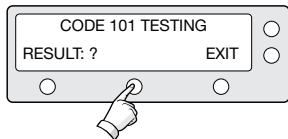

4. CODE 101 is being tested.
Press EXIT to return to main setup mode.

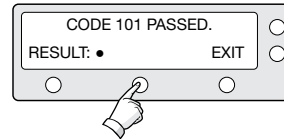

5. **CODE*** 101 has passed.
Press EXIT to return to main setup mode.

CODE*

CODE 101 Data communication between antenna and antenna control unit is tested. If failed, check the RF cable.

CODE 102 AZ CW limit is tested.
If failed, check the limit sensors, motor and belt for AZ axis.

CODE 103 AZ CCW limit is tested.
If failed, check the limit sensors, motor and belt for AZ axis.

CODE 104 EL axis is tested.
If failed, check the limit sensors, motor and belt for EL axis.

CODE 105 Sub reflector is tested.
If failed, check the sub reflector.

CODE 106 LNB is tested.
If failed, check the LNB and control board.

CODE 107 Skew System is tested.
If failed, check the control board, skew motor, and skew sensor.

CODE 108 Antenna Input Power is tested.
If failed, check the RF cable.

CODE 109 ACU Power is tested.
If failed, check the ACU power cable and Input DC power.

CODE 110 IRD Power is tested.
If failed, check the ACU to the IRD cable and IRD power.

RESULT • Test is passed.

STATUS - Test is skipped.

? Test is under process.

Number refers to an error code

(••3••• -•••) 3 means error code 103.

Intellian Satellite TV Antenna Systems

Setting Region

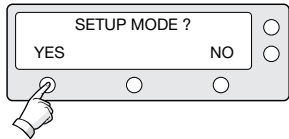

1. Press YES to enter setup mode.

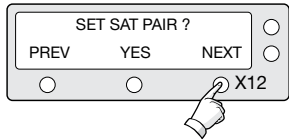

2. Press NEXT twelve times to enter load region information mode.

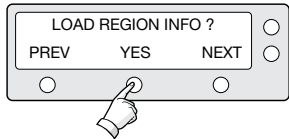

3. Press YES to load region information.

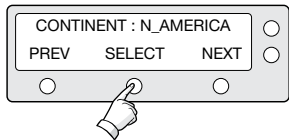

4. Select the **Continent***.
PREV - Shows previous continent.
SELECT - Set the displayed continent.
NEXT - Shows next continent.

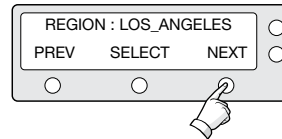

5. Select the **Region***.
PREV - Shows previous region.
SELECT - Set the displayed region.
NEXT - Shows next region.

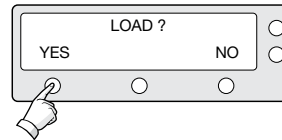

6. Press YES to load region information.
Press NO to cancel and return to main setup mode.

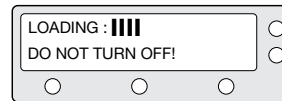

7. After loading, auto restart.

Continent*
N.AMERICA, S.AMERICA, EUROPE, ASIA.

Region*
NEW YORK, MIAMI, UK, JAPAN, and etc.

Setting the Factory Default Parameters

Initialize all of the antenna's information to the factory's default setup.

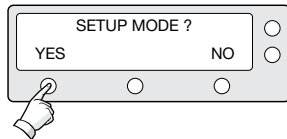

1. Press YES to enter setup mode.

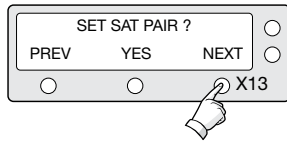

2. Press NEXT thirteen times to enter default setting mode.

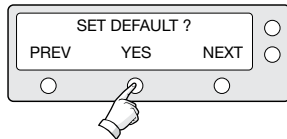

3. Press YES to set default parameters.

Operation Using PC Controller Program

Introduction

GUI Software of Intellian's i2 has been coded for the user to easily set up the antenna by using the user's personal computer. Using the GUI program enables the user to easily monitor and modify the information of the antenna, satellite and GPS. Additionally, the detail diagnostic method of the antenna is provided by the GUI program.

To start this GUI program,

1. Connect one end of PC serial cable to the serial port on the computer.
2. Connect the other end of the PC serial cable to the "PC INTERFACE" on the rear of ACU.
3. Execute GUI program by inserting the supplied CD-ROM into the CDROM drive of the computer.

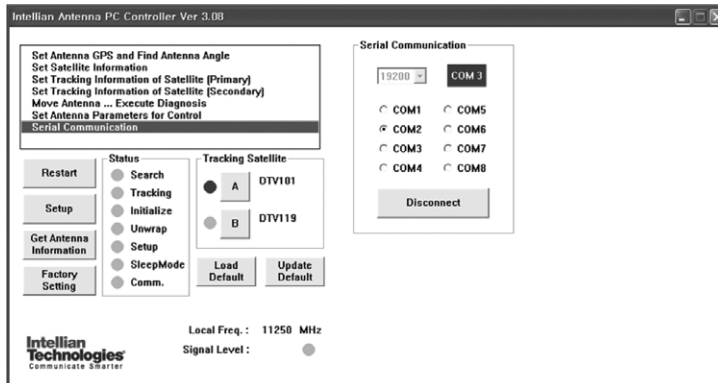

Figure 21 : Intellian Antenna PC Controller Program

Program Initialing and Serial Port Setup

The communication between the ACU and antenna must be established as the first step in order to start setting your antenna.

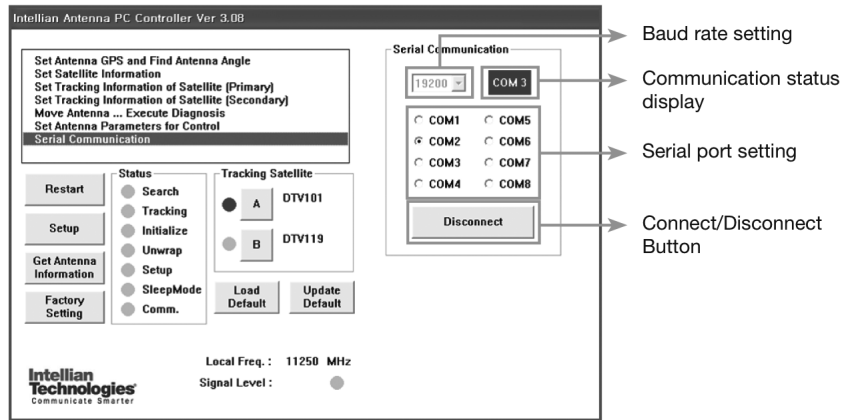

Figure 22 : Setup for Serial Communication

Command Buttons

- Baud Rate Setting – To display data communication speed.
- Communication Status Display – To display data communication between ACU and PC.
- Serial Port Setting – To select serial port to be used.
- Connect / Disconnect – To establish connection between ACU and PC.

Main Menu

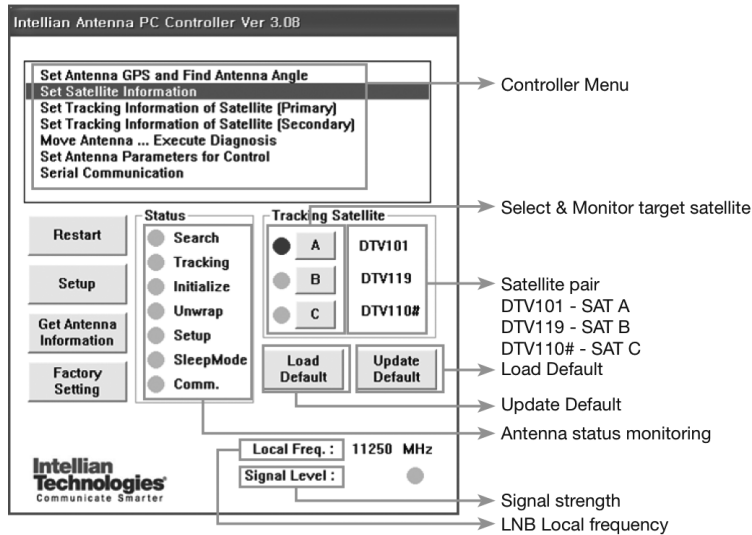

Figure 23 : Setup for Satellite Information in Dual-Sat Mode

Antenna Status Monitoring

- Search – Antenna is searching for the selected satellite.
- Tracking – Antenna is tracking the selected satellite.
- Initialize – Antenna or the ACU is initializing.
- Unwrap – Antenna is unwrapping the wire.
- Setup – Antenna is in setup mode.
- Comm. – Antenna is communicating with the ACU.

Definition of program Command Buttons

- Restart – To exit setup mode and restart the antenna again.
- Setup – To enter setup mode.
- Get Antenna Information – To indicate the information on display after receiving its input from the antenna.
- Factory Setting – To initialize all antenna information to default, the same as it was in ex-factory status.
- Load Default – To load up-to-date information from your PC and input it to the PC program on display.
- Update Default – To update the antenna's information from the up-to-date input to the PC program on display.

Set Region



Figure 24 : Load Regional Library

1. Load default: Click “Load Default” button to select satellite library (*.rif file) according to your current region.

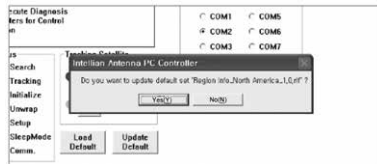

Figure 25 : Confirm the Update

2. Update default: Click “Update Default” button to open update default dialogue. Click “YES” button to update the system.

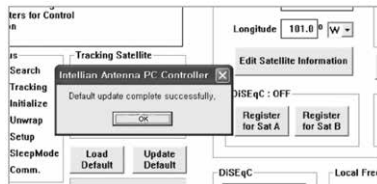

Figure 26 : Updates Completed

3. Click “OK” button to complete the update.

Controller Menu

Set Antenna GPS and Find Antenna Angle

The antenna makes use of the GPS's information to search for the satellite quickly. The more precise the GPS's information is, the quicker the antenna is able to search for the satellite. The method to input information into the GPS is to push the "Set GPS" button after keying in the latitude and longitude information on "City GPS". Pushing the "Add City" button stores the GPS's information. By selecting the stored region in the list box, the GPS information of that region is displayed. The Intellian i2 satellite TV antenna system utilizes the GPS data to locate the satellite faster.

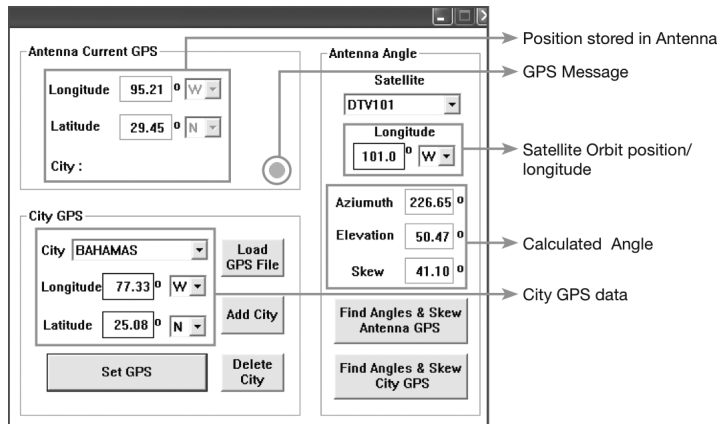

Figure 27 : Antenna Angle and GPS Information

Command Buttons

- Load GPS Files – Reads various city information from the GPS files.
- Add City – Adds the name of city and its GPS information to GPS files.
- Delete City – Deletes the name of city and its GPS information from the GPS files.
- Set GPS – Inputs the indicated GPS information on display to antenna.
- Find Angles & Skew Antenna GPS – Finds the current antenna angle and skew angle in relation to the longitude (orbit position) of satellite and antenna current GPS.
- Find Angles & Skew City GPS – Finds the current antenna angle and skew angle in relation to the longitude (orbit position) of satellite and city GPS.

Setting Satellite Information

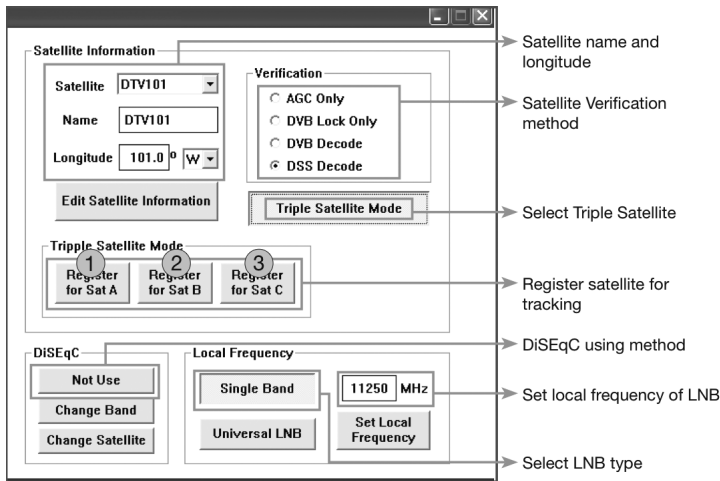

Figure 28 : Setup for Satellite Information

• Satellite Information

The name, longitude and confirmation method of the satellite is displayed when a satellite is selected in the list box. Push the “Edit Satellite Information” button to update the information on modifying the value.

• DiSEqC

When the operation method of DiSEqC is selected to “Change Band”, DiSEqC may be used for updating the local frequency and to “Change Satellite”, for updating the target satellite.

• Registration of target satellite.

Pushing **1** or **2** button after selecting the satellite in the list box makes it possible to register A or B in Dual-sat mode.

Pushing **1** or **2** or **3** button after selecting the satellite in the list box makes it possible to register A or B or C in Tri-sat mode.

• Local Frequency

In case that DiSEqC is selected to “Change Band”, be sure to push the “Universal LNB” button. In case that the DiSEqC is selected to “Not Use” or “Change Satellite”, be sure to push the “Single Band” button and key in into the Local Frequency, and then push “Set Local Frequency” button.

Intellian Satellite TV Antenna Systems

Command Buttons

- Edit Satellite Information – To modify the satellite information.
- Register for Sat A – To register a satellite to satellite A.
- Register for Sat B – To register a satellite to satellite B.
- Register for Sat C – To register a satellite to satellite C. (Tri- Sat Mode)
- Not Use – Do not use DiSEqC.
- Change Band – To use DiSEqC to change band.
- Change Satellite – To use DiSEqC to change the satellite.
- Single Band – Antenna in use of single band LNB.
- Universal Band – Antenna in use of universal LNB.
- Set Local Frequency – To select local frequency of LNB.

Set Tracking Information of Satellite [Primary]

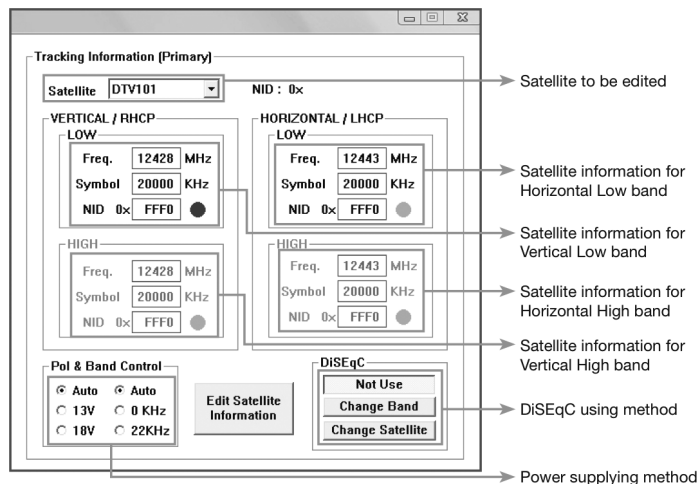

Figure 29 : Setting up the Primary Tracking Information

Command Buttons

- Edit Satellite Information - To change frequency information of the antenna.
- Satellite Information - Satellite information consists of frequency, symbol and NID(Network ID) of a transponder of the tracking satellite. There are four groups of satellite information. 'Vertical/RHCP' is applied when the IRD supplies 13V, and 'Horizontal/LHCP' is applied when the IRD supplies 18V. 'LOW' is applied when the DiSEqC signal is not detected from the IRD, 'HIGH' is applied when the DiSEqC signal is detected from the IRD. If you select 'Not Use' or 'Change Satellite', two 'HIGH' groups are inactivated. If you select Change Band', two 'High' groups are activated and you can modify satellite information which is applied when the DiSEqC signal is detected from the IRD. After modifying the information, press the 'Edit Satellite Information' button, and new information will be updated in the antenna.
- Pol & Band Control - The power controls 13V (Vertical (RHCP)) and 18V (Horizontal (LHCP)) bands. The Band controls High and Low bands. (AUTO RECOMMENDED)

Intellian Satellite TV Antenna Systems

Voltage		DiSEqC		Discription
13V	18V	0KHz	22KHz	
AUTO	AUTO	AUTO	AUTO	13V & 18V and DiSEqC 0KHz & 22KHz tone to LNB
AUTO	AUTO	•		13V & 18V and DiSEqC 0KHz tone to LNB
AUTO	AUTO		•	13V & 18V and DiSEqC 22KHz tone to LNB
•		AUTO	AUTO	13V and DiSEqC 0KHz & 22KHz tone to LNB
•		•		13V and DiSEqC 0KHz tone to LNB
•			•	13V and DiSEqC 22KHz tone to LNB
	•	AUTO	AUTO	18V and DiSEqC 0KHz & 22KHz tone to LNB
	•	•		18V and DiSEqC 0KHz tone to LNB
	•		•	18V and DiSEqC 22KHz tone to LNB

Set Tracking Information of Satellite [Secondary]

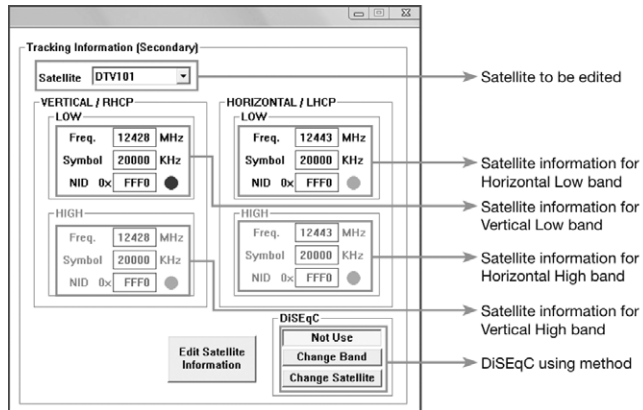

Figure 30 : Setting up the Secondary Tracking Information

Command Buttons

- Edit Satellite Information – To modify the satellite information.

Move Antenna and Execute Antenna Diagnosis

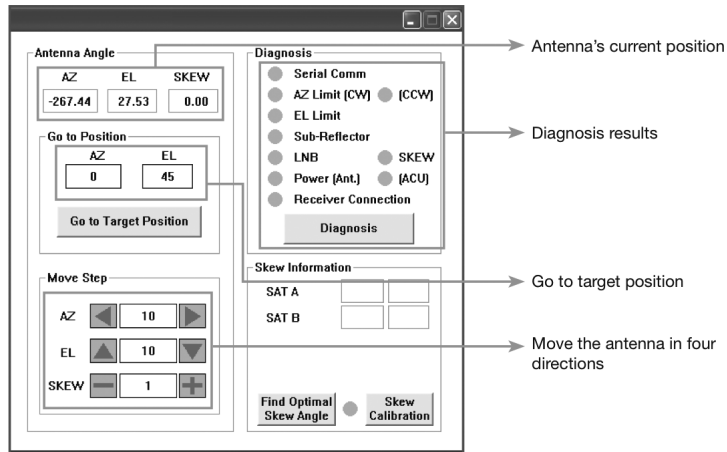

Figure 31 : Antenna Diagnosis

• Angle of Antenna

Two kinds of antenna movement is available. One is to move by the target position and the other is to move by certain amount of angle. The current position (angle) of the antenna is displayed as “Current” and to move to the target position, push “Go to target Position” button after keying in desired angle into “Target”. To move to a certain amount of angle only, move antenna to direction of up or down, and CW or CCW by using ▲▼ ◀▶ buttons after keying in the desired angle into the AZ and EL in the “Move Step” box. Rotate LNB to direct the skew angle by using + – button (Premium model only).

• Self-Diagnosis

If the “Diagnosis” button is pressed, it displays the results of the self-diagnosis after the test is completed. The blue circle means the antenna is normal; red represents abnormal and green represents the antenna is under diagnosis.

Command Buttons

- Go to Target Position – To move the antenna to the present position.
- Diagnosis – To diagnose the antenna
(BLUE – Passed, RED – Failed, GREEN – Under diagnosis)

Set Antenna Parameters for Control

It is not recommended for a novice satellite service to use this mode.

Consult Intellian for changing antenna parameters.

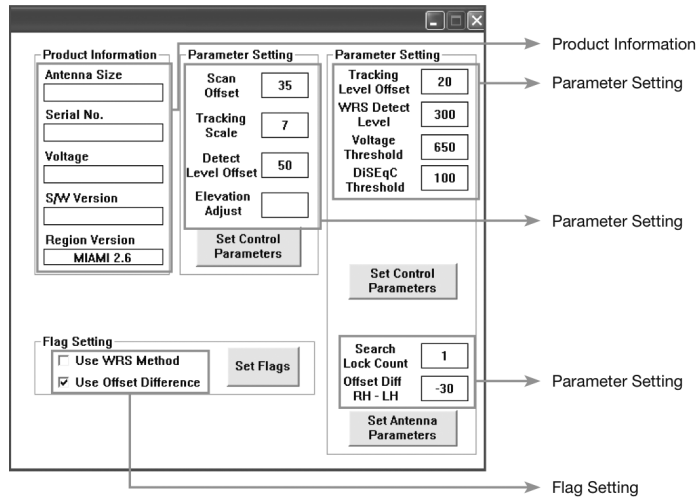

Figure 32 : Antenna Parameters

Command Buttons

- Set Control Parameter - To register parameters value.
- Set Flags - To set flag setting for WRS method or Offset difference.

Intellian Satellite TV Antenna Systems

Parameter Setting - To set antenna parameter values.

Scan Offset The scan offset is to offset the angle difference between the black marker on the sub-reflector and the optical sensor.

Track Scale The track scale is to control the tracking speed while antenna is tracking the satellite.

Detect Level The detect level is to set the satellite signal detection level.

WRS Level The WRS level is to set the WRS detection level.

Track Offset The tracking offset is to offset the satellite signal tracking level.

Power Level The power level is to distinguish the voltage between 13 V and 18 V.

DiSEqC Level The DiSEqC level is to distinguish 0KHz tone and 22KHz tone.

Offset RH-LH The offset RH-LH is to offset the signal difference between RHCP and LHCP.

EL Offset The EL offset is to offset the angle difference between the mechanical elevation angle and actual elevation angle.

Use WRS Use WRS is to determine whether the system uses WRS level or not. "Use WRS" and "WRS Level" are pair functions.

Offset Difference Offset difference is to determine whether the system to uses "Offset RH-LH" or not. "Offset Difference" and "Offset RH-LH" are pair functions.

Preparation for Transportation

This is to describe how to prepare the antenna internally for transportation.

The following procedures to secure the antenna shall be strictly observed to protect it from being damaged during transportation.

1. Refer to the drawing on the right.
2. Rotate antenna left and right slowly until the limit switch is pressed.
3. Turn the antenna by 360° to the reverse direction.
4. Insert the shipping foams in front of the dish and back side of the pedestal to secure the pedestal in position with the bottom radome.
5. Cover upper part of radome being careful for it's not touching the reflector, and then assemble upper part of radome.
6. Pack Intellian i2 into the original package box.

Note: Don't rotate it quickly, or you may damage the antenna limit system.

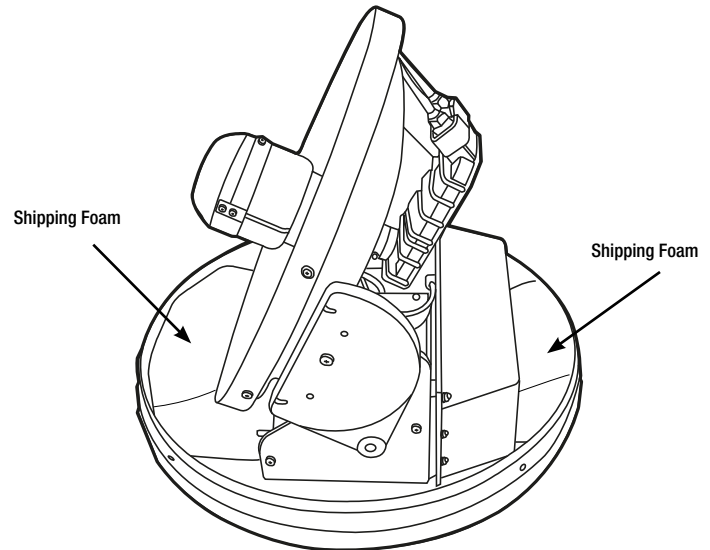

Figure 33 : Preparation for Transportation

Warranty

This product is warranted by Intellian Technologies Inc., to be free from defects in materials and workmanship for a period of THREE (3) YEARS on parts and ONE (1) YEAR on labor performed at Intellian Technologies, Inc. service center from the purchased date of the product.

Appendix : i2 Technical Specification

General

Approvals

CE – conforms to	EU Directive 89/336/EEC
FCC – verified to	CFR47:Part 15

Dimensions

Satellite antenna unit	37cm (14.6") x 38cm(15")
Antenna dish diameter	33cm(13.3")
Antenna control unit	17.8cm(7")x21.7cm(8.5")x5.4cm(2.1")

Weight

Satellite antenna unit	4.5kg (9.5 lbs)
Antenna control unit	1.2kg (2.6 lbs)

Environmental

Operating temperature range	-15°C to +55°C (+5°F to 131°F)
Storage temperature range	-25°C to +70°C (-13°F to -158°F)
Humidity limit	95% R.H
Operating voltage	9 ~ 30V D C
Power consumption	Typ. 30W, Max. 50W

Antenna system performance

Frequency	Ku-band (10.7 to 12.75 GHz)
Minimum EIRP	51 dBW
Azimuth range	680°
Elevation range	+10° ~ +80°
Ship's motion	Roll ±25° Pitch ±15°
Roll and pitch response rate	60° per second
Turn rate	60° per second

Intellian®

APAC

support**APAC**@intelliantech.com

Headquarters

Intellian Technologies, Inc.
348-5 Chungro-Ri, Jinhwa-Myeon
Pyeongtaek-Si, Gyunggi-Do 451-862 Korea
T +82 31 379 1000 F +82 31 377 6185

Seoul Office

Intellian Technologies, Inc.
2F Dongjik Building, 98 Nonhyun-Dong
Gangnam-Gu, Seoul 135-010 Korea
T +82 2 511 2244 F +82 2 511 2235

Americas

support**AMERICAS**@intelliantech.com

Irvine Office

Intellian Technologies USA, Inc.
9004 Research Drive
Irvine, CA 92618 USA
T 949 727 4498 F 949 271 4183

EMEA

support**EMEA**@intelliantech.com

Rotterdam Office

Intellian B.V.
Bristolstraat 1, 3047AB
Rotterdam, The Netherlands
T +31 1 0820 8655 F +31 1 0820 8656

UK Office

Intellian Ltd.
Epsilon House, Enterprise Road, Southampton Science
Park, Southampton, Hampshire SO16 7NS, UK
T +44 2380 019 021 F +44 2380 767 092

Maritime Technical Center

MTC@intelliantech.com

Busan Office

Intellian Technologies, Inc.
#906 Ace High Tech 21, 1470 Woo-Dong
Haeundae-Gu, Busan 612-020 Korea
T +82 51 746 9695 F +82 51 746 9440

www.intelliantech.com