

Intellian[®]

s80HD WorldView[™]

Installation and Operation User Guide

Serial number of the product

This serial number will be required for the all troubleshooting or service inquiries.

Intellian[®]

© 2013 Intellian Technologies Inc. All rights reserved.

Intellian and the Intellian logo are trademarks of Intellian Technologies, Inc., registered in the U.S. and other countries. s80HD WorldView and WorldView Trio LNB are trademarks of Intellian Technologies, Inc. Intellian may have patents, patent applications, trademarks, copyrights, or other intellectual property rights covering subject matter in this document. Except as expressly provided in any written license agreement from Intellian, the furnishing of this document does not give you any license to these patents, trademarks, copyrights, or other intellectual property. All other logos, trademarks, and registered trademarks are the property of their respective owners. Information in this document is subject to change without notice. Every effort has been made to ensure that the information in this manual is accurate. Intellian is not responsible for printing or clerical errors.

INDEX

INTRODUCTION	6
Introduction to Intellian s80HD WorldView™	7
Features of Intellian s80HD WorldView™	8
Basic System Configuration	9
INSTALLING THE ANTENNA	11
System Package	12
Planning the Installation	18
Antenna Installation	22
INSTALLING THE ACU	33
Mounting the ACU	34
Mounting the MSM	34
PC to ACU Communication Setup	40
Wifi Connection	42
OPERATING THE ACU	45
Introduction	46
Normal Mode	48
Setup Mode	53
Installation Settings	54
Antenna Settings	57
Satellite Settings	73
System Settings	84
PC CONTROLLER SOFTWARE	90
PC to ACU Communication Setup	91
Toolbar Menus	93
System Property Status Dashboard	96
Work View Tabs	100
REMOTE ACCESS (WEB MANAGEMENT & CONTROL)	115
Introduction	116
Main Page	117
Antenna Settings	121
Firmware & Configuration	127
Administration	133
WARRANTY	145
APPENDIX: Setup Bluetooth Connection	146
TECHNICAL SPECIFICATION	152

INTRODUCTION

Introduction to Intellian s80HD WorldView™

Features of Intellian s80HD WorldView™

Basic System Configuration

Introduction to Intellian s80HD WorldView™

Intellian s80HD WorldView is a digital marine satellite antenna system specifically designed for reception of worldwide Ku-band satellites as well as the DIRECTV services enabling seamless and uninterrupted satellite TV reception across multiple coverage areas and service providers.

The dual-band 3-axis marine satellite antenna system is capable of receiving two Ka-band satellite signals and one Ku-band signal for DIRECTV® North American programming, enabling all channels to be watched simultaneously. Additionally, the antenna incorporates Intellian's first dual-band LNB combined with WorldView capability. The Intellian Ku- and Ka-band WorldView Trio LNB™ with triple feed horn enables HD and SD TV to be watched anywhere in the world. The user simply selects a satellite television provider and connects to a satellite receiver, allowing the WorldView™ Trio LNB to automatically switch frequency depending on the region the antenna is operating in.

The Intellian Multi-Switch module with the built-in SWM (Single Wire Multi-switch) and standard-type Multi-switch outputs provides simple connection to different satellite receivers enabling TV viewing on multiple TV screens. The s80HD WorldView antenna provides total solutions for uninterrupted satellite receptions without requiring complex installation and re-configuration of systems.

The s80HD WorldView features Intellian's patented WRS (Wide Range Search) algorithm for fast signal acquisition. Designed to excel in all sea states and weather conditions, the s80HD is tested to industry-leading standards for vibration and resonance frequency, as well as extreme shock.

Features of Intellian s80HD WorldView™

Intellian WorldView™ Trio LNB for Global Service Compatibility

The Intellian s80HD WorldView incorporates the Ku- and Ka-band LNB combined with Intellian WorldView LNB module. The Intellian WorldView™ Trio LNB is designed to receive on all linear polarizations as well as left and right hand circular polarizations enabling global satellite services capability. The LNB module is programmed to select each satellite's L.O automatically allowing boaters to enjoy simple operation from the Americas (circular polarized) through the Europe, the Middle East and the Asia Pacific regions (linear polarized).

Multi-Switch Module

The Intellian Multi-Switch module is included in the system and provides simple connection to different types of satellite receivers. The built-in SWM outputs and standard multi-switch outputs support both Single Wire and standard installations, reducing the need for additional hardware and reconfiguration of the system when viewing programs on multiple TV screens.

DVB-S2 Signal Identification

Intellian s80HD WorldView is fully compatible with DVB-S2 signals. It detects, identifies, and tracks satellite transmitting the DVB-S2 signal format. A capable satellite TV receiver and subscription is required.

Global Satellite Library

The pre-programmed Global Satellite Library allows the user to select the desired TV satellite service while traveling from region to region. Once the satellite is selected the WorldView™ Trio LNB module will automatically switch to the corresponding local frequency to receive the signal.

Dedicated Management Ethernet Port

The Management Ethernet Port on the front of ACU enables direct and simple network connection between a PC and the ACU. The Management Port supports DHCP network connection by default, allowing automatic IP configurations and quick access to Intellian's remote management solution, the Web Management and Control.

Wireless Connectivity and Intellian App

The built-in WiFi enables the ACU to be wirelessly connected and can be either turned on and off by a switch. Any kind of wireless devices such as PCs, laptops and smartphones can be used to connect to the ACU and monitor, control and change the settings of the system wirelessly. The D-Sub Connector on the antenna can be connected to a Serial to Bluetooth converter (optional) enabling the user to monitor the antenna inside the Radome using a PC with Bluetooth connectivity. An Intellian App is available for download to access to the ACU via Wi-Fi and operate the antenna from their iPhone, iPad or other network devices. iPhone and iPad are registered trademarks of Apple Inc.

Basic System Configuration

For your satellite TV system to work properly, the system will have to be connected with all of the provided components properly, as shown in the figure below. Separate purchase of a satellite receiver and a TV is required.

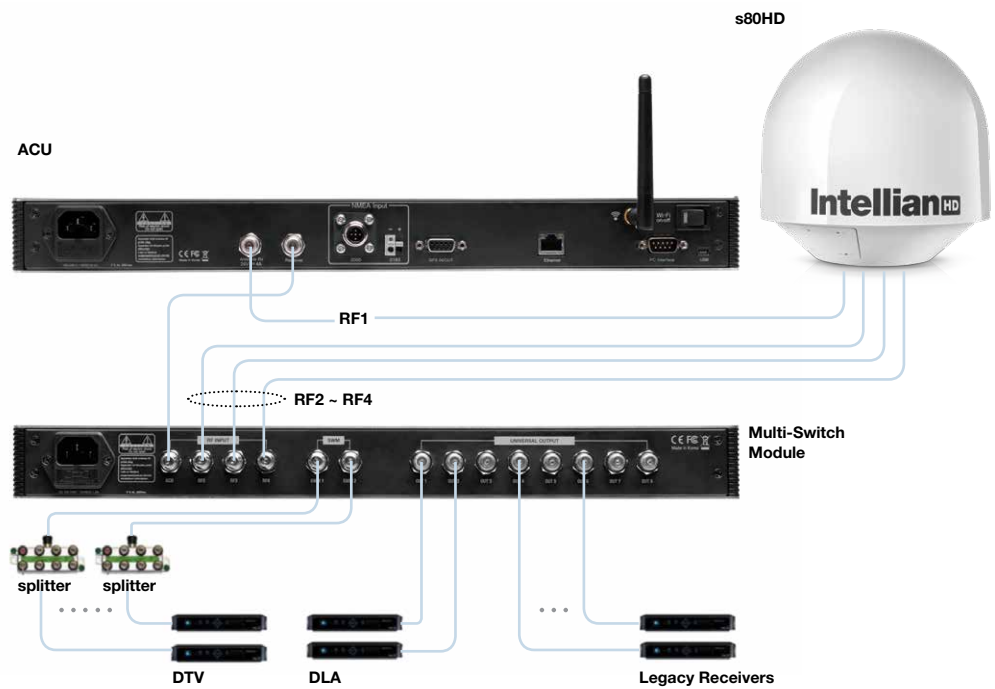

Figure 01. Basic System Configuration

Basic Steps for system setup and connection.

1. Connect the RF cable from the RF1 connector on the power switch box located inside the radome to the ANT. Rx connector on the ACU.
2. Connect the RF cable from the RECEIVER connector on the ACU to the ACU connector on the Multi-switch module.
3. Connect the RF cable from the RF2 connector on the power switch box to the RF2 connector on the Multi-switch module.
4. Connect the RF cable from the RF3 connector on the power switch box to the RF3 connector on the Multi-switch module.
5. Connect the RF cable from the RF4 connector on the power switch box to the RF4 connector on the Multi-switch module.
6. To connect SWM compatible receivers, connect an RF cable from the SWM connector on the Multi-switch module to a SWM receiver. Up to 16 DTV receivers can be connected using the provided splitters as shown in the diagram.
7. To connect other non-SWM compatible receivers, connect RF cable(s) from the UNIVERSAL OUTPUT (1~ 8) to desired standard receiver(s).
8. Connect the ship's gyro to the NMEA Input on the ACU.
9. Connect the power cable from the AC power connector on the ACU to a power source at 100- 240 V AC.
10. Press the power switch on the ACU to start the operation of the antenna system.

INSTALLING THE ANTENNA

System Package

- Antenna Unit
- Antenna Control Unit (ACU)
- Multi-Switch Module (MSM)
- Antenna Installation Kit
- ACU Installation Kit
- Multi-Switch Module (MSM) Installation Kit
- Other Components

Planning the Installation

- Selection of Antenna Installation Site
- System Cables
 - RF Cables (Customer Supplied)
 - Gyro Compass / GPS Interface Cable (Customer Furnished)
- Power Requirements
- Tools Required for Installation

Antenna Installation

- Unpacking the s80HD Package Box
- Antenna Dimensions
- Antenna Mounting Templates
- Position the Radome
- Mounting the Radome
- Installing the System Cables
- RF Cable Connections
- Reinstall the top radome.

System Package

The Intellian s80HD WorldView™ consists of three major units, an antenna assembly unit, antenna control unit and multi-switch module.

Antenna Unit

The antenna unit includes an antenna pedestal inside a radome assembly unit. The pedestal consists of the satellite antenna main dish and sub-reflector module with a WorldView™ Trio LNB module mounted on a stabilized pedestal. The radome protects the antenna pedestal assembly unit from the severe marine environment.



Figure 02. Antenna Unit

Antenna Control Unit (ACU)

The Antenna Control Unit (ACU) provides power to the antenna and controls various settings of the antenna. Additionally, VFD (Vacuum Fluorescent Display) allows for you to operate the ACU in the dark.



Front



Rear

Figure 03. Antenna Control Unit

The functions of the ACU are as follows :

- System startup
- Change of target satellite
- Monitoring current status
- Setting antenna manual search
- Setting antenna set skew
- Setting antenna search parameter
- Setting antenna set parameters
- Executing antenna diagnosis
- Setting the satellite pair
- Edit satellite information
- Setting the region
- Finding transponders
- Setting the GPS and Gyrocompass
- System backup & restore
- Copy log and firmware upgrade through USB
- Supports Wi-Fi ACU operation
- Built-in web-based remote control management
- Front panel Management Ethernet port
- Installation settings

Multi-Switch Module (MSM)

The Intellian Multi-Switch Module provides built-in SWM and standard multi-switch outputs allowing configuration with DIRECTV satellite receivers and standard satellite receivers.



Front





Rear

Figure 04. Multi-Switch Module

Antenna Installation Kit

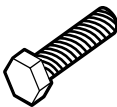
Contains the items required for securing the antenna unit to your vessel.

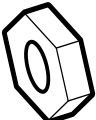
Antenna	Q'ty	Description	Size	Remark
	5	Hex. Bolt	M12 x 80L	
	5	Flat Washer	M12	
	5	Spring Washer	M12	Antenna-Deck
	10	Hex. Nut	M12	

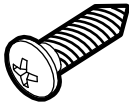
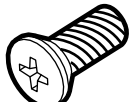
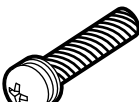

ACU Installation Kit

Contains the items required for securing the ACU to your vessel.







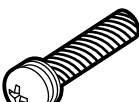

ACU	Q'ty	Description	Size	Remark
	5	Self-Tapping Screw	Ø4 x 16	Table Mount Bracket
	10	Flat Head Screw	M3 x 8L	Rack Mount Bracket ACU
	5	Sems Bolt	M3 x 12L	Table Mount Bracket ACU

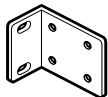
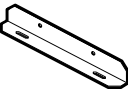

Multi-Switch Module (MSM) Installation Kit

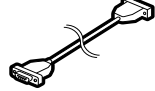
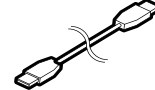
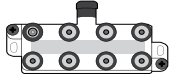
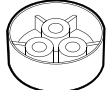
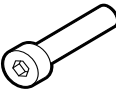
Contains the items required for securing the Multi-Switch module to your vessel.

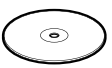
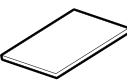
ACU	Q'ty	Description	Size	Remark
	5	Self-Tapping Screw	Ø4 x 16	Table Mount Bracket
	10	Flat Head Screw	M3 x 8L	Rack Mount Bracke
	5	Sems Bolt	M3 x 12L	Table Mount Bracket

Other Components

Item	Image	Q'ty	Description	Size	Remark	
1		4	Brackets for ACU (2EA), MSM (2EA)	Rack	-	19 inch Rack
		4		Table	-	Table Mount
2		4	RG6 Cable	15m	ACU - ANT (1EA), ANT - MSM (3EA)	
3		2	RG6 Cable	3m	ACU - MSM (1EA), MSM - Reciever (1EA)	
4		2	AC Power Cord (CEE7/7)	1.5m	ACU Power / MSM Power	
5		1	PC Serial Cable	1.8m	ACU to PC	
6		1	USB Cable (A-A / M-M)	1.8m	ACU to PC	
7		2	8-way splitter for SWM	-	MSM's SWM to DirecTV receivers	
8		2	Rubber Gland	RG6	Antenna Cables	
9		5	Hex Socket Head Cap	M6 x 40L	Radome (Top - Bottom)	
10		5	Dome Washer	M6	Radome (Top - Bottom)	
11		1	Software CD	-	-	
12		1	User Manual	-	-	
13		1	USB Flash Driver	-	-	

Item	Image	Q'ty	Description	Size	Remark
14		1	WiFi Antenna	110mm	-
15		1	Mounting Template	-	-

Planning the Installation

Selection of Antenna Installation Site

Install the antenna in accordance with the following procedures to ensure maximum performance of the antenna. The ideal antenna site should have a clear view of the horizon or satellite all around it. Please be sure there are no obstacles within 15° above the center of the antenna. Any obstacles can prevent the antenna from transmitting and receiving the satellite signal.

Do not install the antenna near the radar especially on the same plane as its energy levels may overload the antenna's front-end circuits. It is recommended to position the antenna at least 4 feet (1.2 m) above or below the level of the radar and minimum of 15 feet (4.6 m) away from any high power short wave radars.

The mounting platform should be rigid enough and not subjected to excessive vibration. The movement of the antenna can be minimized by installing at the center of the vessel. If these conditions can be only partially satisfied, choose the best installation site between various considerations that can satisfy the mentioned conditions.

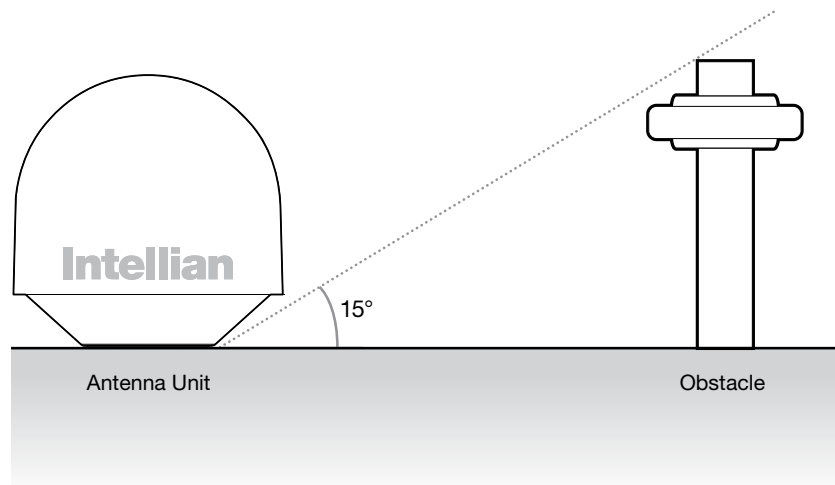

Figure 05. Elevation Limit of Obstacle

System Cables

Before installing the system cables, you need to take the following points into consideration.

- All cables need to be well clamped and protected from physical damage and exposure to heat and humidity.
- Cable with an acute bend is not allowed.
- Where a cable passes through an exposed bulkhead or deck head, a watertight gland or swan neck tube should be used.

RF Cables (Customer Supplied)

Due to voltage losses across the length of the RF coax on L-Band, Intellian recommends the following 75 ohm coax cable types for standard system installations. For cables that run longer than 100 meters, please consult Intellian Technologies.

Run Length	Coaxial Cable Type
Up to 35 meters	RG-6 or LMR-300-75
Up to 60 meters	RG-11 or LMR-400-75
Up to 100 meters	LMR-600-75

Gyro Compass / GPS Interface Cable (Customer Furnished)

Type	Multi-conductor, Shielded
Number of wires	2 conductors for NMEA/NMEA2000

Power Requirements

Intellian s80HD has been designed to work on a vessel’s power supply rated at 100-240 V AC.

• GPS Connector

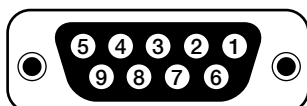

ACU GPS In/Out Port
D-Sub 9 pin Female

Pin	Signal
1	GND
2	GPS OUT +
5	GPS IN +

• NMEA 2000 Connector

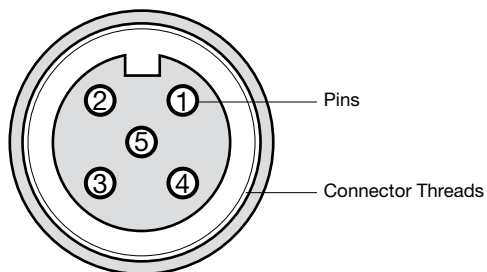

Male Connector

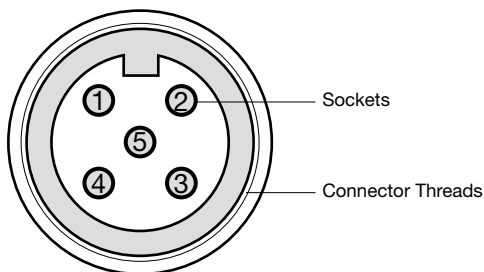

Female Connector

Pin	Signal
1	Shield
2	NET-S, (power supply positive, +V)
3	NET-C, (power supply common, -V)
4	NET-H, (CAN-H)
5	NET-L, (CAN-L)

Pin	Signal
1	Shield
2	NET-S, (power supply positive, +V)
3	NET-C, (power supply common, -V)
4	NET-H, (CAN-H)
5	NET-L, (CAN-L)

Tools Required for Installation

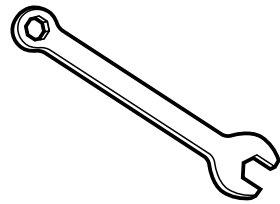

11 mm Wrench

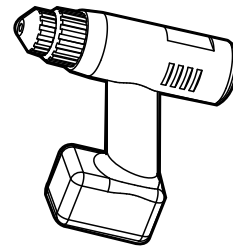

Power Drill

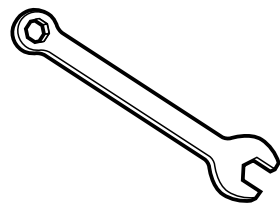

13 mm Wrench

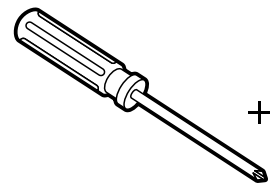

Phillips Head Screwdriver

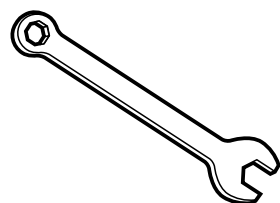

19 mm Wrench

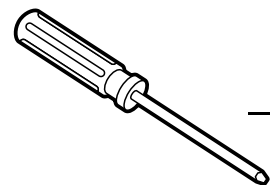

Flat Head Screwdriver

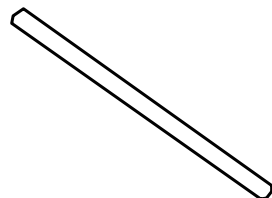

5 mm Allen/Hex key
(for Power drill)

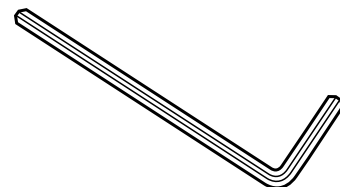

5 mm Allen/Hex key

Figure 06. Tool Sets for Installation

Antenna Installation

Unpacking the s80HD Package Box

Step 1.
Remove the top panel.

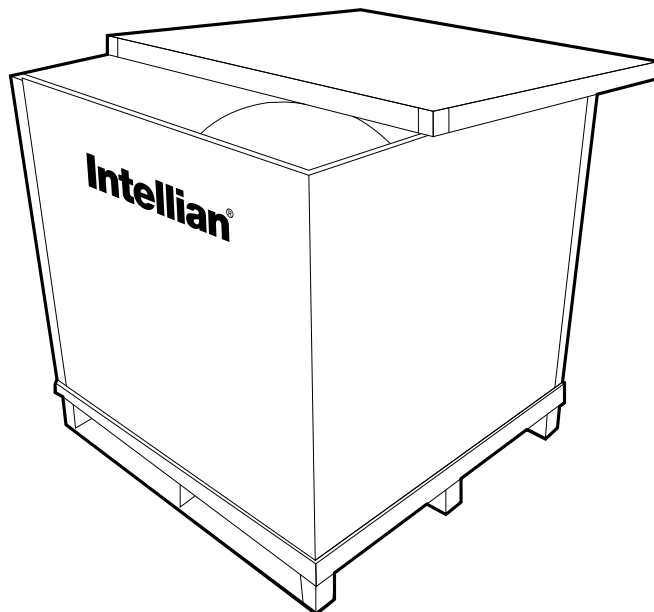

Step 2.
Remove ACU box, Multi-switch module box and installation kit box.

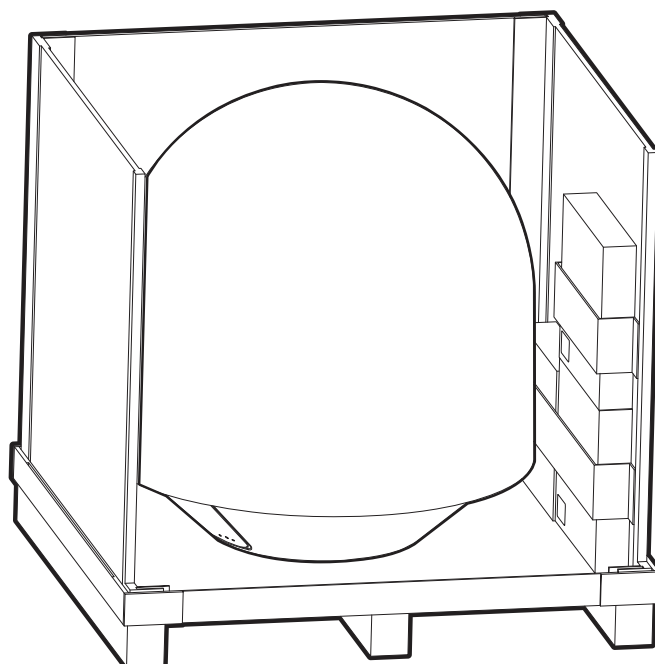

Step 3.

Remove the 4 shipping bolts that mount the antenna to the pallet.

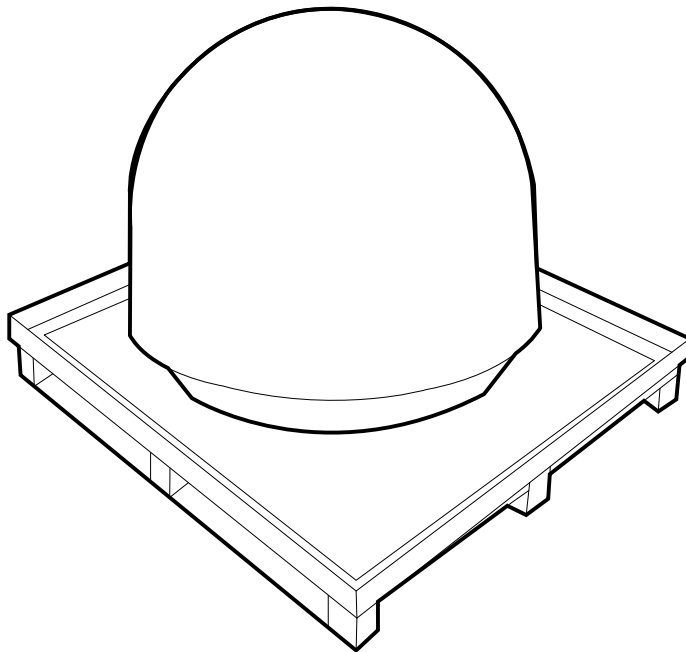

Step 4.

Open the top radome and remove the shipping restraints

(3 red fixing brackets are mounted to the antenna pedestal (1EA) and the azimuth axis (2EA).)

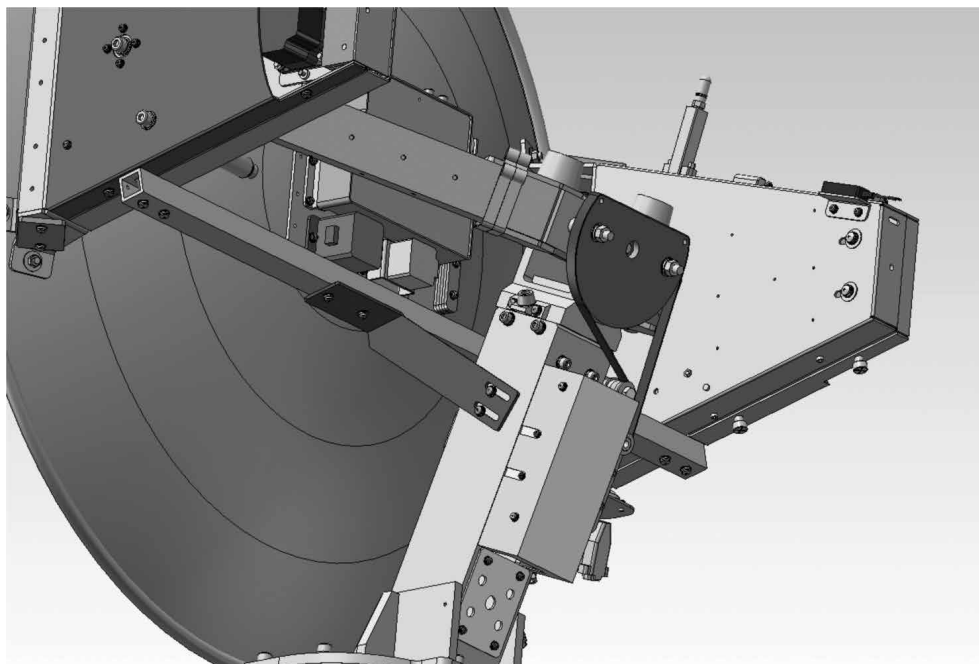
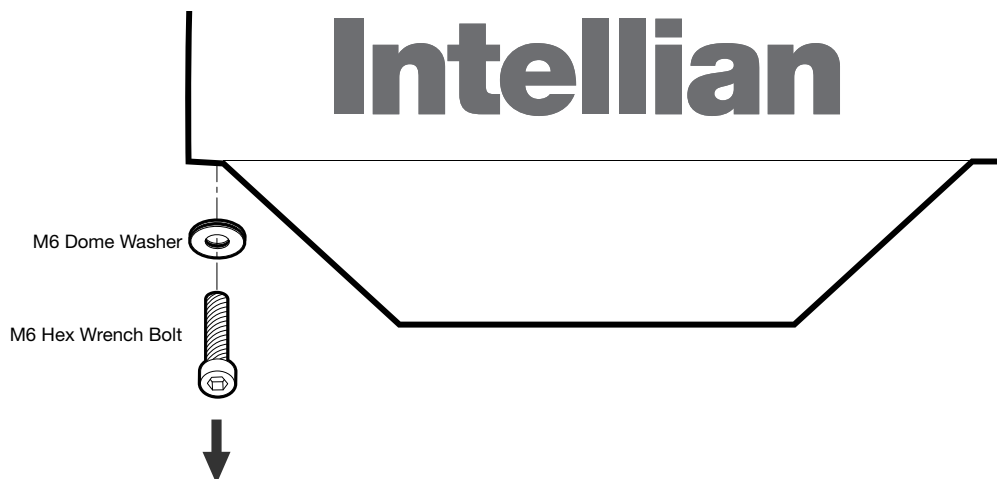

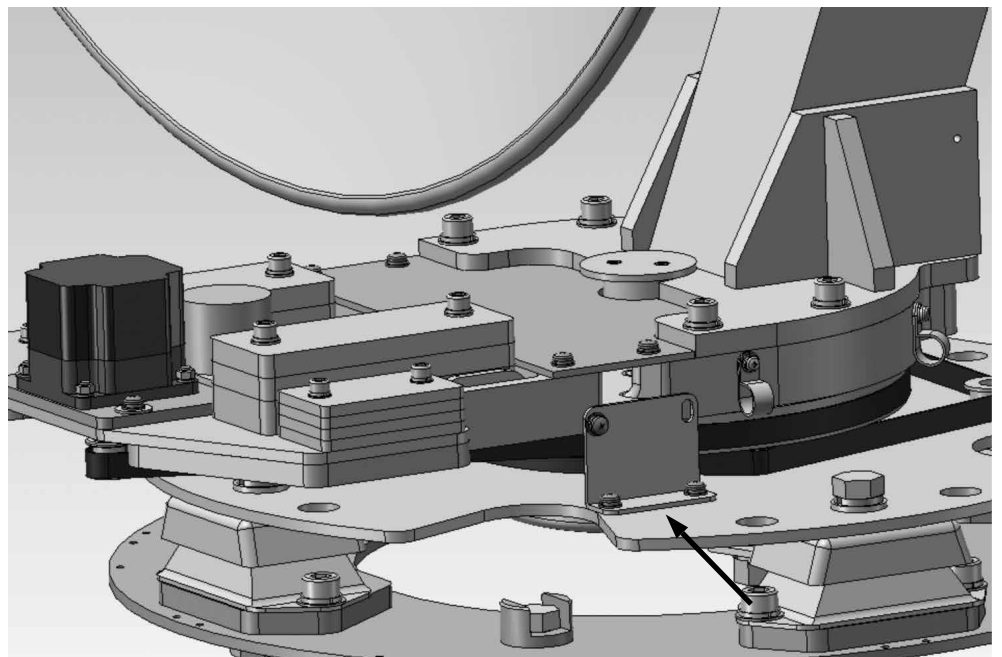
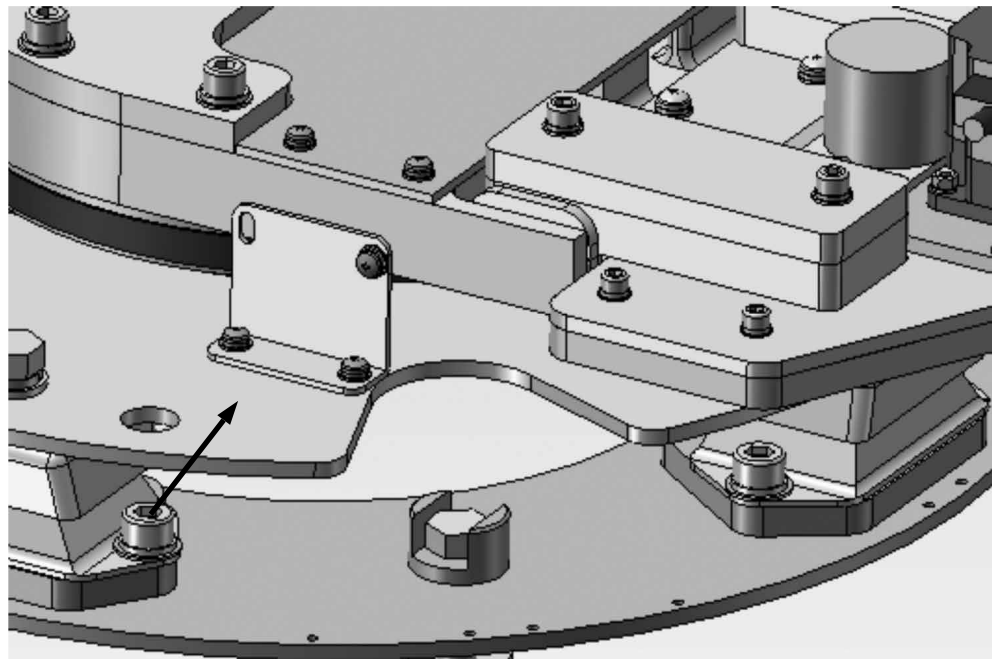

Antenna Dimensions

The method of installation and mounting of the antenna may vary with vessel design but the following procedures are applicable in most situations, and will result in a secure and effective installation. Confirm the height and diameter of the antenna before installing it.

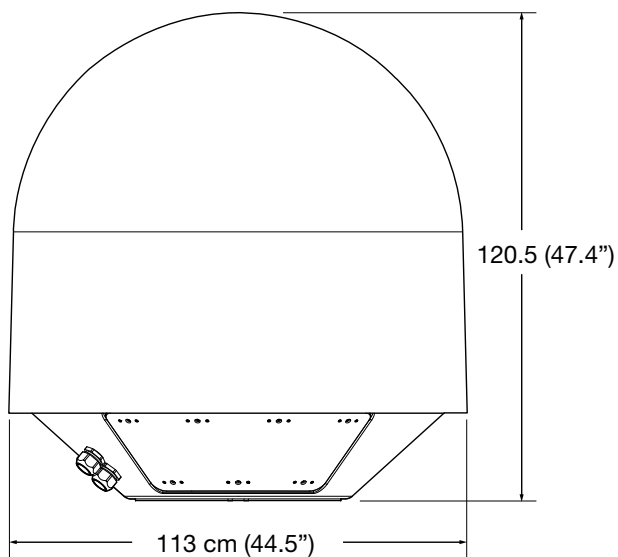

Figure 07. Radome Dimension of s80HD

Antenna Mounting Templates

The mounting holes must be in the exact same place as shown in the diagram below.

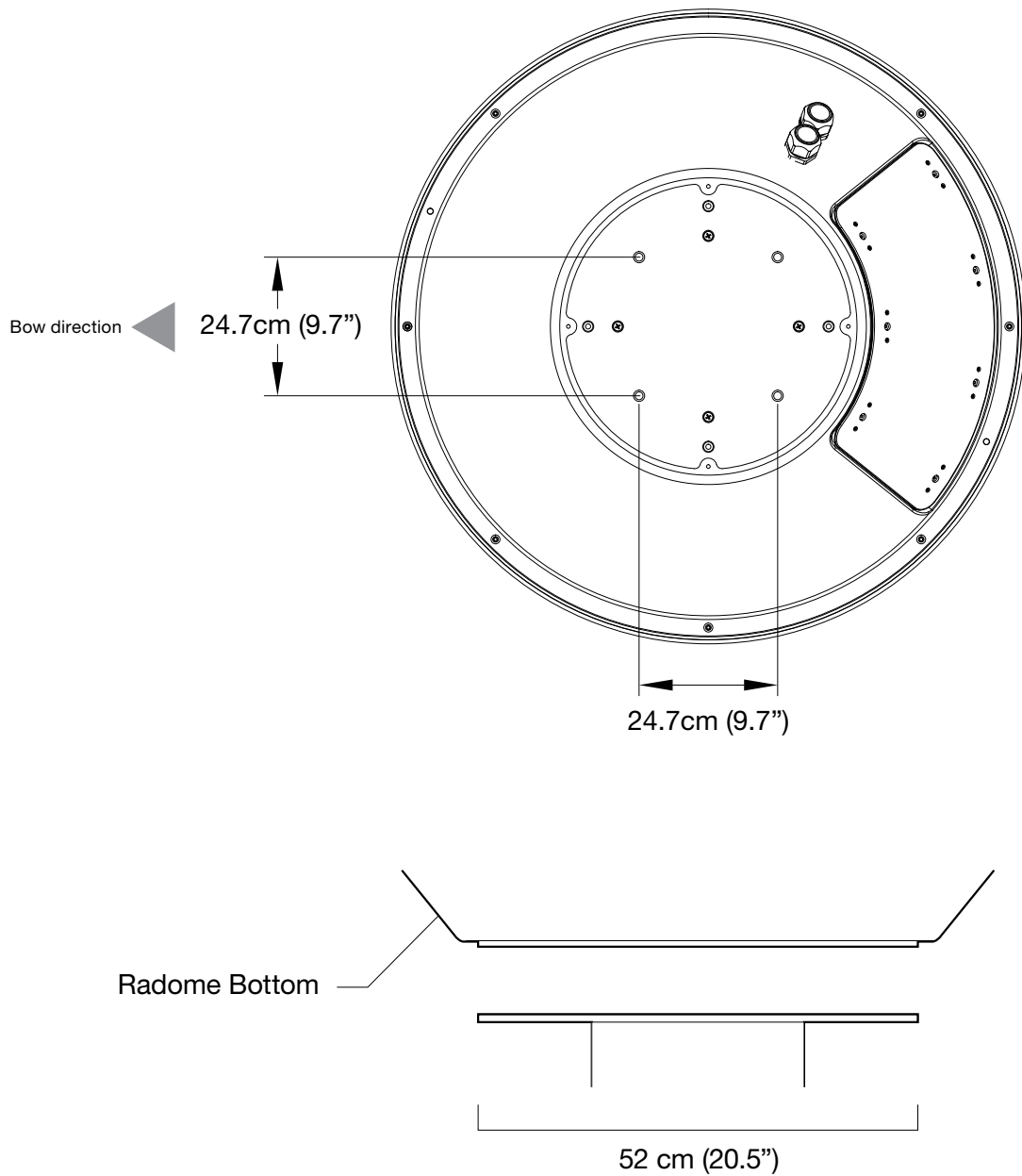

Figure 08. Mounting Pattern of s80HD

Position the Radome

The radome should be positioned with the BOW marker aligned as closely as possible to the ship's centerline.

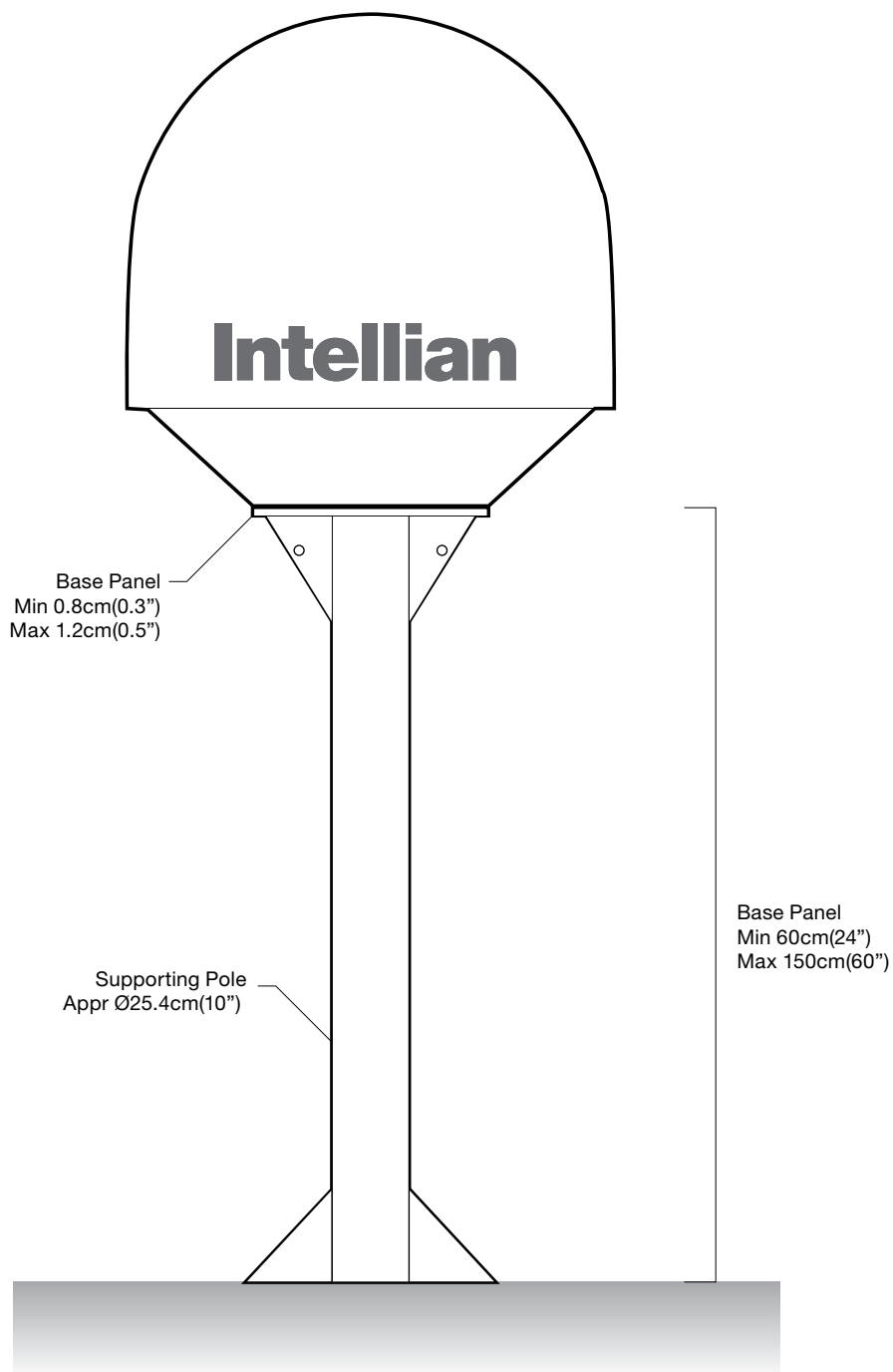

Figure 09. Recommended size of the support pedestal

Mounting the Radome

Bolt the radome base directly to the support pedestal. Make sure to use the Intellian supplied bolts from the accessory box when you mount the radome.

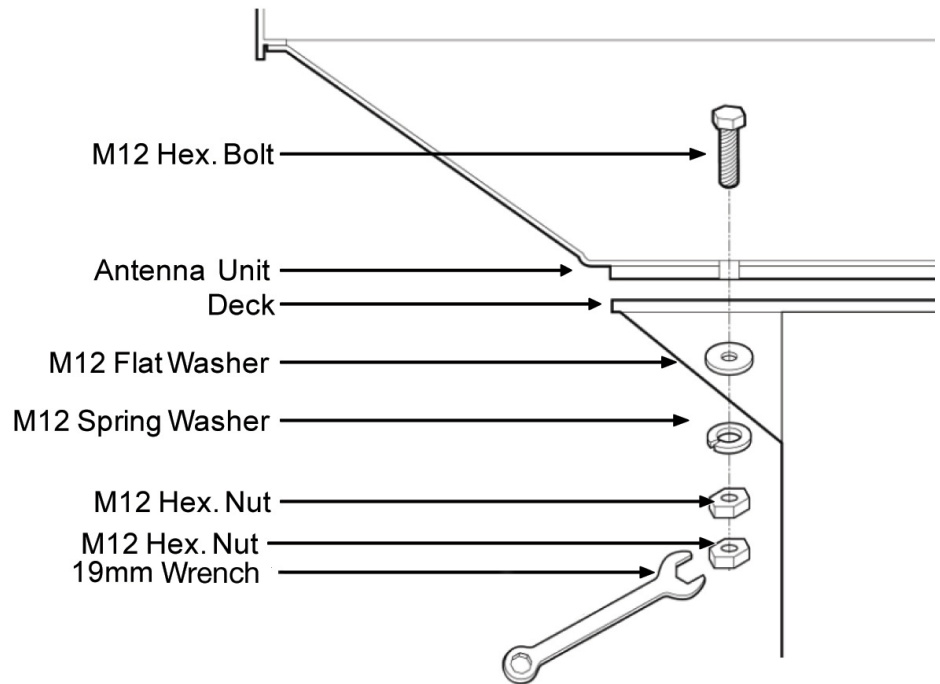

Figure 10. Mounting Components Diagram

NOTE: The double Hex. nuts are used as lock nut.

Installing the System Cables

The coax cables must be inserted through the cable strain relief(s) at the base of the radome. The cables must be routed from the antenna through the deck and through various ship spaces to the antenna control unit. When pulling the cables in place, avoid sharp bends, kinking, and the use of excessive force. After placement, seal the deck penetration gland and tie the cables securely in place.

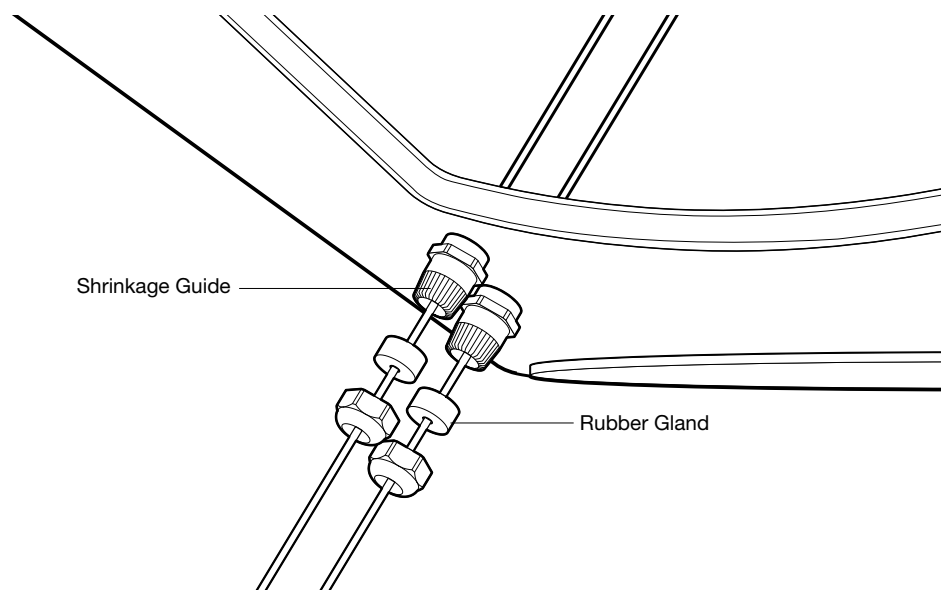

Figure 11. Cable Entry Diagram

NOTE: The rubber gland that comes as standard is for RG11 cable type. For installation of RG6 cables, replace it with the supplied RG6 type rubber glands in the installation box.

RF Cable Connections

Before installing the RF cable, ensure that the RF cable labeled with RF1 has to be connected properly between the antenna control unit and the power switch box. Connect the four RF cables to the RF connectors using an 11mm wrench. Ensure that the power switch is off during the installation period. When all the hardware and cables have been installed, turn on the power switch. Use an RG6 rubber gland if you're using an RF6 cable instead of an RG11 cable supplied by Intellian.

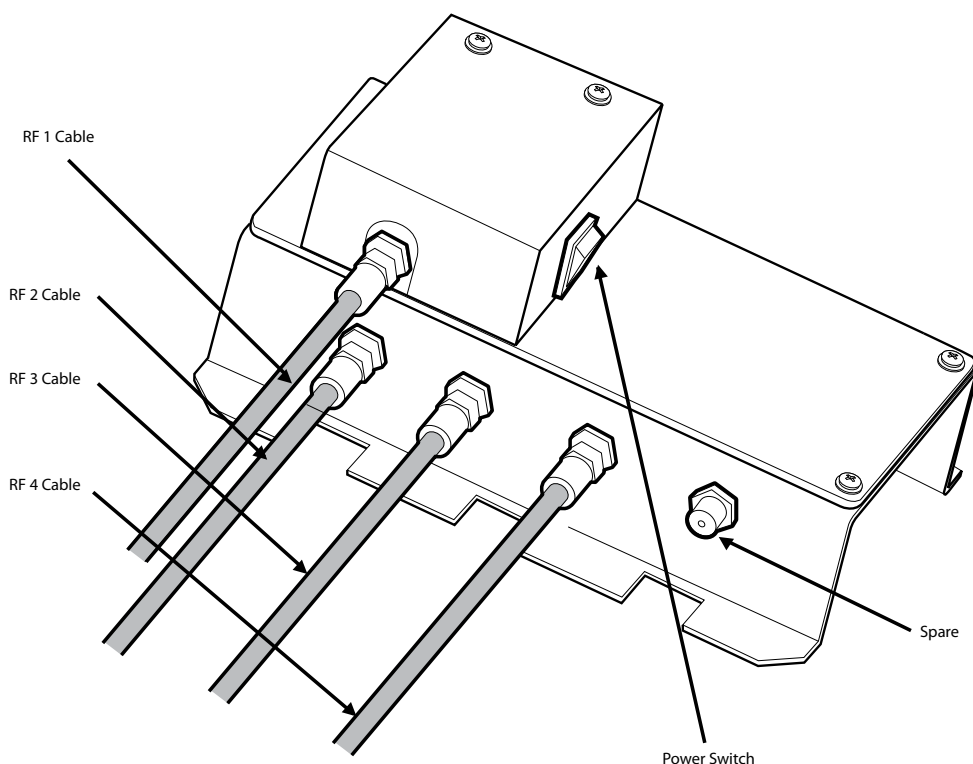

Figure 12. Cable Connection on Power Switch Box

Reinstall the top radome.

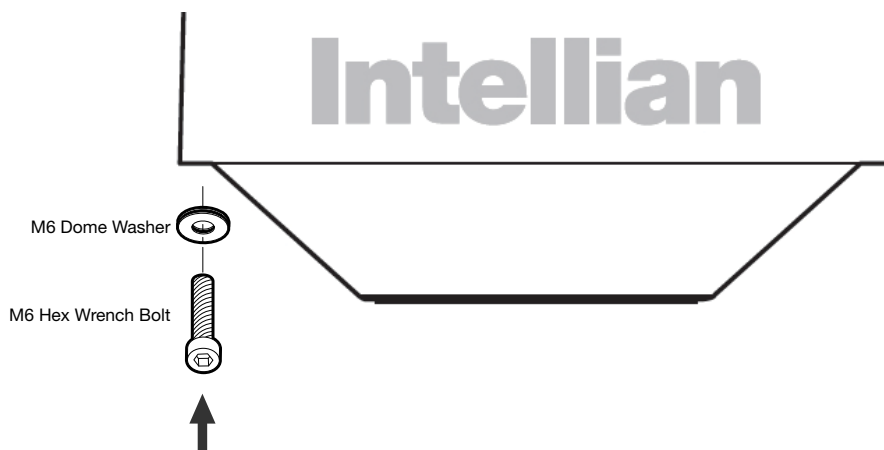

Figure 13. Top Radome Reinstallation

It is recommended to fasten the bolt to a torque setting of 8 N·m. Do not overtighten the bolt, otherwise it may crush the gasket washer.



WARNING: Please ensure that your Intellian system is ALWAYS powered ON upon leaving the dock. Failure to follow these instructions could result in damaging mechanical parts in the antenna and/or possibly void your warranty. Intellian strongly recommends to restrain the antenna pedestal properly while underway when power is removed from the antenna. The normal operating condition for the t80W is to remain powered up at all times.

INSTALLING THE ACU

Mounting the ACU

Mounting the MSM

ACU Dimensions

MSM Dimensions

Ship Gyro Connection

Connecting the System without a Ship's Gyrocompass

Connecting the ACU and MSM

Connecting the MSM and Receivers

PC to ACU Communication Setup

TCP/IP Connection

Serial/USB Connection

Wifi Connection

Setup WiFi Connection

Setting up the ACU in order to access WiFi

Setting up the PC in order to access WiFi

Mounting the ACU

Intellian supplies two types of mounting methods (a)19 inch Rack Mount Type and (b)Table Mount Type to mount your ACU.

19 inch Rack Mount Type

The ACU should be installed using the two supplied Rack Mounting Brackets which allow for a side 19 inch rack mounting configuration.

- Using the self tapping screws supplied, attach the mounting brackets to the sides of the ACU.
- Place the ACU in the location where it is going to be installed.
- Connect the cables to the rear of the ACU.

Table Mount Type

- The ACU should be installed using the two supplied Table Mounting Brackets which allow for a top or bottom mounting configuration.
- Using the self tapping screws supplied, attach the mounting brackets to the sides of the ACU.
- Place the ACU in the location where it is going to be installed.
- Using a pencil to mark the 4 hole positions (2 on each side), and use the appropriate drill bit to drill them.
- Connect the cables to the rear of the ACU.

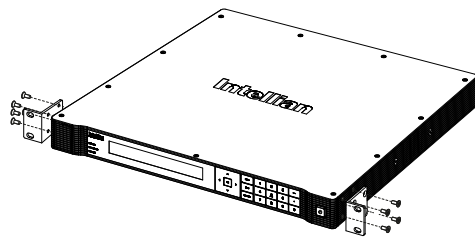

Figure 14. 19 inch Rack Mount Type

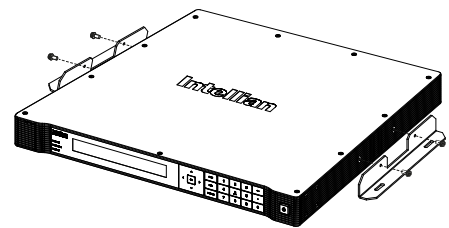

Figure 15. Table Mount Type

Mounting the MSM

Follow the identical steps for the ACU above to mount the MSM to a rack or table.



WARNING

WARNING: Ensure that the cables connected to the ACU and MSM are long enough to prevent damage when the ACU and MSM is pulled out from the rack.

ACU Dimensions

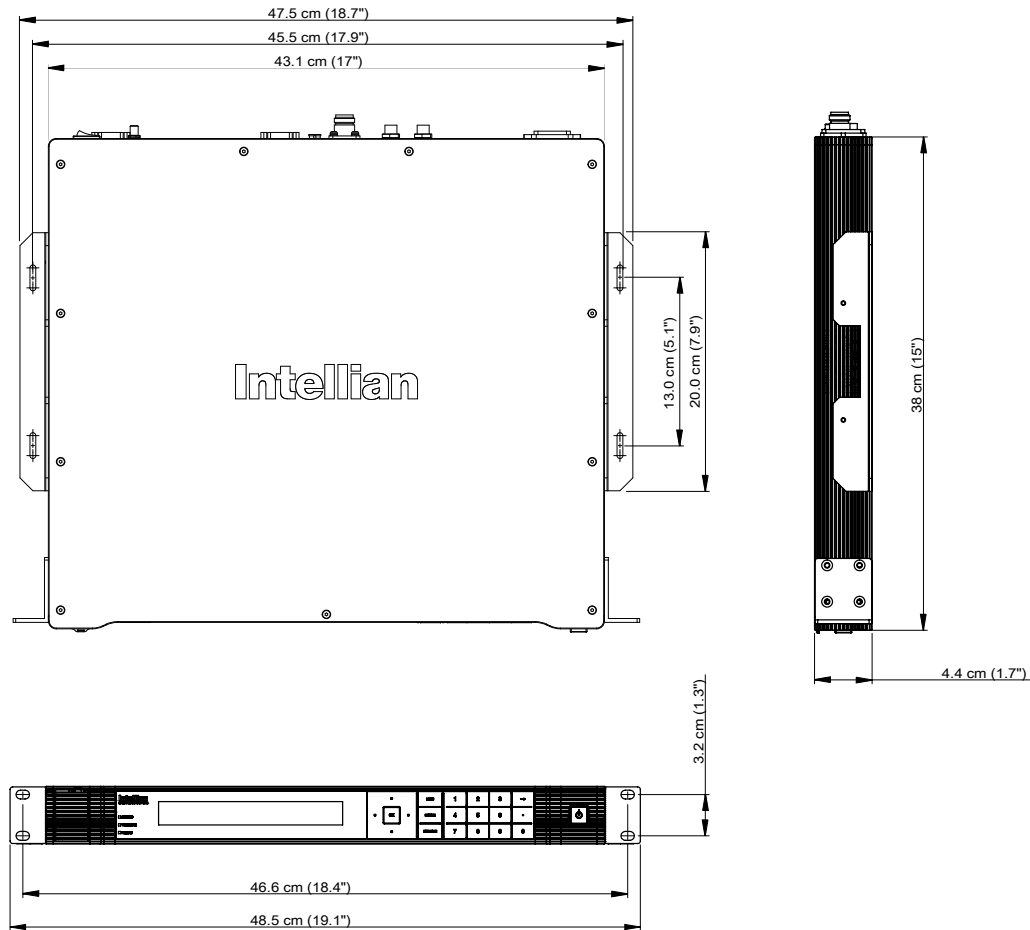

Figure 16. Dimension of ACU

MSM Dimensions

Dimensions of the multi-switch module is identical for the ACU dimensions.

Selection of ACU Installation Site

- The ACU should be installed below deck, in a location that is:
- Dry, cool, and ventilated.
- Horizontal and solid surface to support the weight of the ACU (7.7 lbs) and all other loads of distribution amplifiers and receivers.

Ship Gyro Connection

For satellite tracking, you must connect a ship's Gyro to the antenna system through the gyro interface on the rear of the ACU. If the ship's gyrocompass output is other than NMEA 0183 and NMEA 2000 a separate purchase of a gyro converter is required.

- NMEA 0183 Gyrocompass Interface Cable (Customer supplied)
- Type: 2 conductors for NMEA 0183
- NMEA heading sentence: xx HDT (4800 Baud, 8, N,1) If there is no HDT sentence then use HDM sentence instead.
- NMEA 2000 heading PGN Number = 127250 (Vessel Heading)

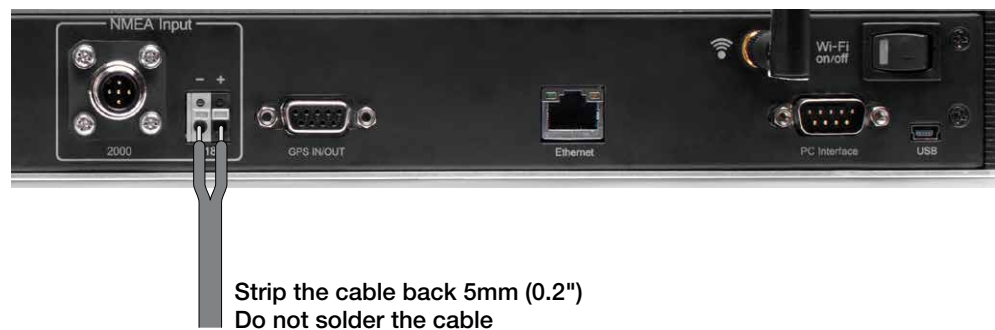

Figure 17. Ship's Gyro Connection

Connecting the System without a Ship’s Gyrocompass

For a vessel where the ship’s gyrocompass is not installed or is difficult to be connected, the Intellian Gyro-Free satellite search function will be automatically enabled to allow the antenna to lock onto the desired satellite without requiring an external heading input.

The table below provides an example of the Gyro-Free satellite search algorithm. The Search 1 or Search 3 satellite search pattern will be triggered according to the existence of heading input and the setting of the heading device.

Search 1: This mode is entered from Search 1 or Search 3. The antenna will search for the target satellite by turning its azimuth angle in CCW (Counter Clockwise) direction until the antenna receives the lock signal from the receiver or the DVB(Digital Video Broadcasting) transponder of the target satellite is decoded by the antenna.

Search 2: The antenna will search for the target satellite by turning in a two-axis pattern consisting of alternate movements in azimuth (AZ) and elevation, until the antenna receives the lock signal from the receiver or the DVB transponder of the target satellite is decoded by the antenna.

Search 3: The antenna will search for the target satellite by turning its azimuth angle directly to the position calculated using the ship’s heading input and lock onto the satellite.

Existence of Heading Data	Setting of Heading Device		
	No Device	NMEA / NMEA 2000	Ground Test
With Heading Data	Search 1	Search 2	Search 2
Without Heading Data	Search 1	Search 1	Search 2

*** Search 1 and Search 2 will enter to Search 3 mode once the desired signal is found.**

Quick Setup Procedure

- Set the satellite with DVB transponder as the target satellite.
- Set “No Device” to the heading device.
- The antenna will search for the target satellite by turning its azimuth angle in CCW direction and lock onto the satellite signal until the antenna receives a lock signal from the receiver or the DVB transponder of the target satellite is decoded.
- Set the heading device as NMEA.
- Enter “Manual search” menu and touch “Function” key to save the current settings. Intellian ACU will automatically calculate and save the bow offset.
- Upload the real TARGET satellite pre-configured from the library.

Connecting the ACU and MSM

Ensure to set up and connect the Multi-Switch Module to the ACU.

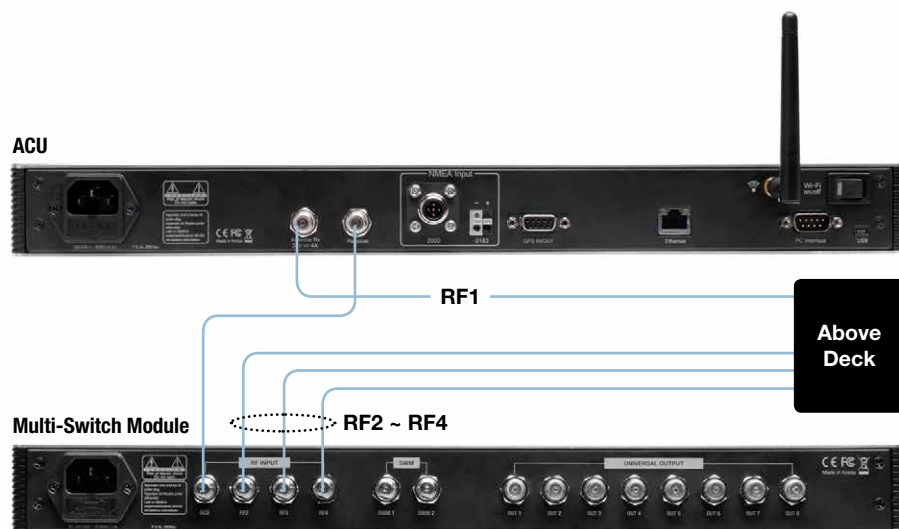

PC to ACU Communication Setup

You can establish data communication between a PC and the ACU using one of the following methods.

TCP/IP Connection

Connection through Front Panel Management Port

This method is most recommended. Network is automatically configured by DHCP without the need of additional PC IP configuration.

Management Ethernet Port

1. Connect an Ethernet cable from a PC Ethernet port to the Management port on the front of the ACU.
2. Network connection is established.
3. Use the following IP address to access Intellian Aptus® or Web M&C page.
 - 192.168.2.1 (Default)



Connection through Rear Panel Ethernet Port

This method requires separate IP configuration on a PC.

Ethernet Port

1. Connect an Ethernet cable from a PC Ethernet port to an available LAN port of a Switch/Hub.
2. Go to Control Panel > Network and Sharing Center > Change Adapter Settings and right-click on the Local Area Connection then click Properties
3. Select TCP/IPv4, then click Properties.
4. Change the network settings on a PC;
 - Default IP: 192.168. 0.222 (Secondary: 10.10.1.2)
 - Subnet Mask: 255.255.255.0
 - Gateway: 192.168.0.223 (Secondary: 10.10.1.1)
5. Use the following IP address to access Intellian Aptus® or Web M&C page.
 - Default: 192.168.0.223 (Secondary: 10.10.1.1)

Serial/USB Connection

Serial Connection **Connection through Serial Port**

1. Connect a 9-pin Serial cable from the PC INTERFACE connector on the ACU to the 9-pin serial port on your PC.
2. If there is not a 9-pin serial port on the PC, use a USB-Serial adapter.

USB Connection **Connection through USB Port**

There are two USB(USB-to-Serial) ports are available on the ACU. One is on the front and the other is on the rear.

1. Connect a USB cable from a USB port on your PC to the USB port on the ACU.

Note: The s80HD also supports Wi-Fi connection between PC and the ACU and Bluetooth connection between PC and the antenna. To setup Wi-Fi or Bluetooth connection, refer to page 42 and 146, respectively.

WiFi Connection

Setup WiFi Connection

- Setting up the ACU in order to access WiFi
- Setting up the PC (Adhoc Mode) in order to access WiFi
- Remote Web M&C Confirmation

Setting up the ACU in order to access WiFi



1. Turning on the WiFi switch

Turn on the switch on the back of the ACU, and 30 seconds after enabling the power supply, confirm if a red light appears on the switch.

Setting up the PC in order to access WiFi

1. Setting up my computer’s wireless IP address

- Control Panel> Network and Sharing Center > Change Adapter Settings > Right click on the “Bluetooth Wireless Connection”> Click Properties

After selecting TCP/IPv4, click on the properties menu, then select "Obtain an IP address automatically."



2. To manually change the network settings, click on "Use the following IP address" and use the settings listed below.

Case #1

If Ethernet to Serial (E2S) Module’s IP is known
The E2S module’s default IP is 192.168.1.223

PC IP : 192.168.1.222
Subnet Mask : 255.255.255.0
GateWay : 192.168.1.223

Case #2

If Ethernet to Serial (E2S) Module’s IP is unknown
The E2S module’s secondary IP is 10.10.10.1

PC IP : 10.10.10.2
Subnet Mask : 255.255.255.0
GateWay : 10.10.10.1

3. Connect WIFI in Ad-hoc mode.

After clicking on the Windows Wireless Connection icon, click on intellian-WIFI (Default)

4. Enter the Network Security Key.

Key: intellian1234 (Default)



5. You can confirm the logo and version data by accessing <http://192.168.1.223>

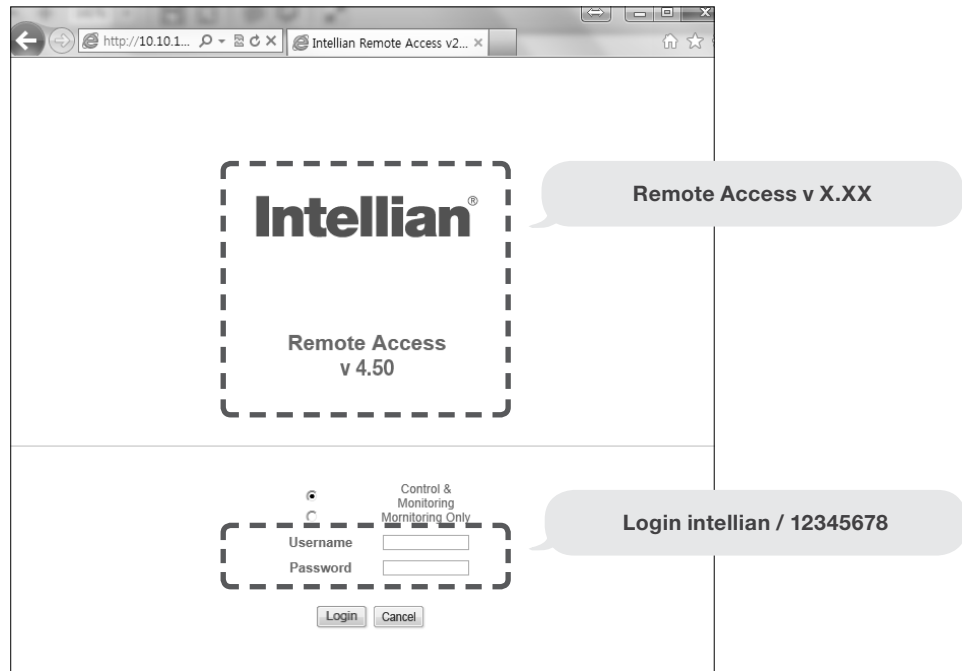

Login by entering the ID / Password listed below.

Username: intellian (Default)

Password: 12345678 (Default)

6. When you login, make sure that all the data within every page is being displayed correctly.

OPERATING THE ACU

Introduction

Normal Mode

Startup

Change of Target Satellite

Monitoring Current Status

Setup Mode

To enter Set-up Mode simply follow the instructions below:

Installation Settings

Installation

Antenna Settings

Setting Antenna Manual Search

Antenna LNB Skew Angle

Setting Antenna Search Parameters

Setting Antenna Parameters

Performing Antenna Diagnostic Tests

Satellite Settings

Setting the Satellite pair

Edit Satellite Information

Setting the Region

Finding the Transponder

System Settings

Setting the GPS and Gyrocompass

System Management

Key Lock

Introduction

This section of the handbook describes how to set up your Satellite TV System after Installing the ACU or GUI PC controller program and includes the following functions:

Normal Mode

- System startup
- Change of target satellite
- Monitoring current status

Starting Setup Mode

Installation Setting

Setting the Antenna

- Setting antenna manual search
- Setting antenna set skew
- Setting antenna search parameter
- Setting antenna set parameters
- Executing antenna diagnosis

Setting the Satellite

- Setting the satellite pair
- Edit satellite information
- Setting the region
- Finding transponders

Setting the System

- Setting the GPS
- System Management

ACU Soft Keys

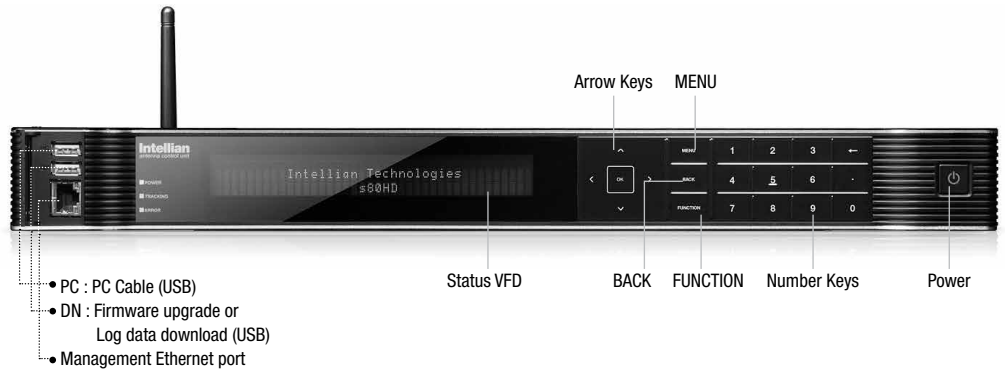

Soft Key Functions

Soft key	Function
MENU	Enter SETUP mode
BACK	In SETUP mode: returns to the previous menu / option or save the adjusted settings. In normal mode: returns to the first page of the antenna's current status.
FUNCTION	Save the adjusted settings.
ARROW KEYS	Select from the alternative options to increase or decrease the selected character to the desired value.
OK	Enter the next step / menu
NUMBER KEYS	Input the numbers

Normal Mode

Startup

With the system installed and power applied, the ACU screen will show the following sequence.

```
INTELLIAN TECHNOLOGIES INC.  
INTELLIAN s80HD
```

1. The data communication is being established between the antenna and the ACU.

```
INITIALIZE – ANTENNA INFO  
INTELLIAN s80HD
```

2. The ACU receives antenna information.

```
INITIALIZE – EL POSITION  
INTELLIAN s80HD
```

3. The elevation angle and cross level angle are initialized.

```
INITIALIZE – AZIMUTH POSITION  
INTELLIAN s80HD
```

4. The azimuth angle is initialized.

```
INITIALIZE – FIND NOISE LEVEL  
INTELLIAN s80HD
```

5. The antenna measures the noise levels of the default satellites.

```
INITIALIZE – SAT POSITION  
INTELLIAN s80HD
```

6. The antenna returns to the target satellite position.

```
SEARCH3 DTV101 AGC: 301 ● [VL] ▸  
AZ: 292.7 ( 202.7) EL: 48.3 SK: ▲-72.0 ▾
```

7. The antenna has locked onto the satellite.

```
TRACKING DTV101 AGC: 501 ● [VL] ▸  
AZ: 292.7 ( 202.7) EL: 48.3 SK: ▲-72.0 ▾ Fn
```

8. The antenna has locked onto satellite [1] and is now tracking.

Change of Target Satellite

Your antenna is programmed with three candidates of target satellites as default. To change the target satellite, press the LEFT soft key. The target satellite is changed and is automatically tracked by the antenna.

```

# TRACKING [→] ASTRA_1      #
                [2] HOT_SPOT [3] ASTRA_3  Fn

```

1. Press key 2 for tracking satellite [2].

```

# TRACKING [→] HOT_SPOT    #
                [1] ASTRA_1  [3] ASTRA_3  Fn

```

2. The antenna is tracking satellite [2].

```

# TRACKING [→] ASTRA_1      #
                [1] HOT_SPOT [3] ASTRA_3  Fn

```

3. Press key 3 for tracking satellite [3].

```

# TRACKING [→] ASTRA_3      #
                [1] ASTRA_1  [2] HOT_SPOT  Fn

```

4. The antenna is tracking satellite [3].

Monitoring Current Status

While POWER ON the Intellian s80HD ACU displays the status of the antenna. Various ACU displays may be shown according to the current status of the antenna.

```
SEARCH [→] DTV101
[2] DTV119
```

1. The antenna is searching for satellite [1].

```
TRACKING [→] DTV101
[2] DTV119
```

2. The antenna is tracking satellite [1].

```
ANTENNA IS UNWRAPPING
```

3. The antenna is winding/unwinding the cables in the antenna. The necessity of "unwrap" is based on how far the ship has turned in one direction on the other.

```
TRACKING [→] DTV101
[2] DTV119
```

4. The antenna is again tracking satellite [1].

```
SAVE CURRENT SAT INFO?
→YES NO
```

5. Press the FUNCTION key to save current satellite information. Then abort and return to the main display.

```

┌ TRACKING [→] DTV101      ↵
└                [2] DTV119      Fn

```

6. While the antenna is tracking satellite [1], press the RIGHT arrow key to display current antenna information.

```

┌ TRACKING [→] DTV101  AGC: 301● [VH] ↵
└ AZ: 051.7 (231.7) EL: 48 3  SK: 14.0↵ Fn

```

7. True azimuth [231.7] position of the antenna is the sum of ships heading 180.0 [HDG] and antenna relative [51.7]. Current IF signal (AGC) is displayed. ● will only be displayed when the signal is strong enough to lock. [VH] indicates vertical high band. VL: Vertical Low, HL: Horizontal Low, HH: Horizontal high. Press the UP and DOWN arrow keys to increase and decrease the LNB skew angle. If UP and DOWN arrow marks are not displayed on the screen, press the OK key 3 times in a row.

```

┌ DBV_D F: 11856 S: 27500 X0001 AGC: 124  ↵
└ 127.05E 41.50N HDG: 180.0 L: 9750

```

8. Press the RIGHT arrow key to display current satellite, GPS and ship's heading [HDG] information.

Satellite Information :

Verification method: DVB_Decode
 Frequency: 11856
 Symbol Rate: 27500
 NID: x0001
 LNB local frequency: 9750

GPS Information :

Longitude : West/East
 Latitude : North/South

Heading Information :

HDG: 180.0

```

┌ [PWR] ANT: 23.9V      LNB: 13V + 0KHz  ┐
└           ACU: 27.0V      IRD: 13V + 0KHz  ┘
    
```

9. Press the RIGHT arrow key to display ACU and antenna, LNB and IRD voltage information.

Antenna and ACU Voltage :

Due to the voltage losses across the RF1 coaxial cables, ensure that the minimum ACU operation voltage is within 27 + 1 V DC and the minimum antenna operation voltage is above 16V DC.

LNB and IRD Voltage :

Voltage		DiSEqC		Discription
13V	18V	0KHz	22KHz	
•		•		Vertical Low
	•	•		Horizontal Low
•			•	Vertical High
	•		•	Horizontal High

```

┌ T2-878T      ANT. Serial  1.00/1.00  ┐
└ BP-T851     ACU Serial   1.00(1.00) ┘
    
```

10. Press the RIGHT arrow key to display the antenna, ACU and Library version. Keep pressing the RIGHT arrow key to return to the main display.

Setup Mode

To enter Set-up Mode simply follow the instructions below:

```
⊕ TRACKING [→] DTV101      ⊕  
                [2] DTV119      Fn
```

1. While the antenna is tracking, press the MENU key for setup menu.

```
                SETUP MENU ?  
→YES                NO
```

2. Press the LEFT key to move cursor to YES and press the OK key to enter setup menu or press the RIGHT key to move cursor to NO and press the OK key to abort and return to the main display.

Installation Settings

Installation

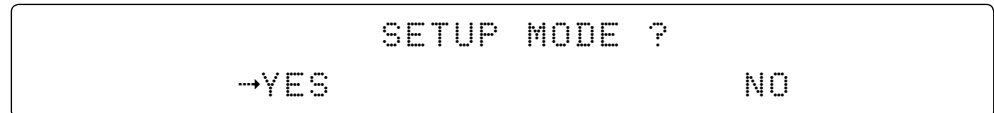

1. Press the LEFT arrow key to move cursor to YES and press the OK key to enter setup mode.



2. Press the arrow key to move cursor to INSTALLATION and press the OK key to enter **INSTALLATION** menu.

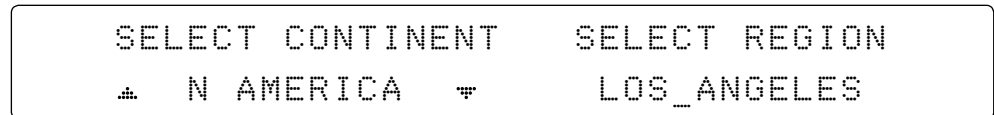

3. Set the **CONTINENT & REGION**.
Press the UP and DOWN arrow keys to select the continent & region that you are in.
Press the OK key to set the settings.

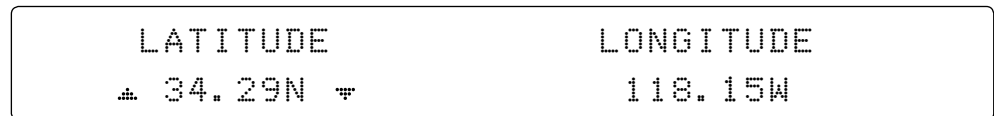

4. Set the current **LATITUDE**.
Press the LEFT and RIGHT arrow keys until the desired character is underscored (selected). Press the UP and DOWN arrow keys to increase or decrease the value.
Or press the NUMBER keys to set the desired value directly.
Press the OK key to set the **LATITUDE**.

LATITUDE	LONGITUDE
34.29N	▲ 118.15W ▼

5. Set the current **LONGITUDE**.

Press the LEFT and RIGHT arrow keys until the desired character is underscored (selected). Press the UP and DOWN arrow keys to increase or decrease the value. Or press the NUMBER keys to set the desired value directly.

Press the OK key to set the **LONGITUDE**.

GYRO TYPE	BOW OFFSET
▲ NMEA ▼	000

6. Set the **GYRO TYPE**.

Determine the type of gyro compass that is used on the ship. Ensure that the Gyro Type is set correctly. Press the UP and DOWN arrow keys to select the gyro type and press the OK key to set the **GYRO TYPE**.

GYRO TYPE	BOW OFFSET
NMEA	▲ 000 ▼

7. Set the **BOW OFFSET**.

The radome should be positioned with the BOW marker aligned as close as possible to the centerline of the ship. Small variations from actual alignment can be compensated with the BOW OFFSET, so precise alignment is not required.

Press the LEFT and RIGHT arrow keys until the desired character is underscored (selected). Press the UP and DOWN arrow keys to increase or decrease the value. Or press the NUMBER keys to set the desired value directly.

Press the OK key to set the **BOW OFFSET**.

```
                                LOAD ?
      →YES                                NO
```

8. Press the BACK key to load the current setting or abort and return to the main display.

```
LOADING . . . ●●●○○○○○○○○○○○○○○○○○○
DO NOT TURN OFF !
```

9. Setting is being loaded to the system.
The ACU will restart the system automatically after uploading the setting.
DO NOT turn off ACU power while uploading is being processed.

```
⌘ SEARCH      [→] DTV101      ⌘
                   [2] DTV119
```

10. Region information has been updated.

Antenna Settings

Setting Antenna Manual Search

```

                SETUP MODE ?
      →YES                      NO
  
```

1. Press the LEFT key to move cursor to YES and press the OK key to enter setup mode.

```

→+ANTENNA                      +SATELLITE
  +SYSTEM                       +INSTALLATION
  
```

2. Press the OK key to enter **ANTENNA** menu.

```

→+MANUAL SEARCH                +SET POL ANGLE
  +SEARCH PARAM                 +SET PARAMETERS
  
```

3. Press the OK key to enter **MANUAL SEARCH** menu.

```

STEP SIZE  AZIMUTH  ELEVATION  AGC
#  0.2    #  ← 288.7  ↑  ▲ 41.0  ▸  288  Fn
  
```

4. Current IF signal level (AGC) is displayed to assist you in manually peaking EL for best signal level. Press the NUMBER key to change the step size. (Range : 0.1~9.9) Press the LEFT and RIGHT arrow keys to move azimuth by step size. (Range : 0~360) Press the UP and DOWN arrow keys to move elevation by step size. (Range : 0~90) Press the FUNCTION key to save current value or abort and return to the main display.

```

                SAVE CURRENT SAT INFO ?
                YES                      NO
  
```

5. If the current settings are able to locate the satellite, press the LEFT key to move cursor to YES and press the OK key to save the settings. It will shorten the satellite acquisition time next time. Or you can press the RIGHT key to move cursor to NO and press the OK key to abort and return to the main display.

Antenna LNB Skew Angle

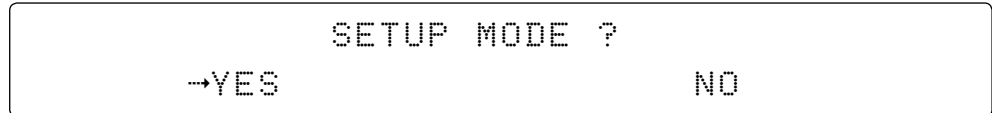

1. Press the LEFT key to move cursor to YES and press the OK key to enter setup mode.

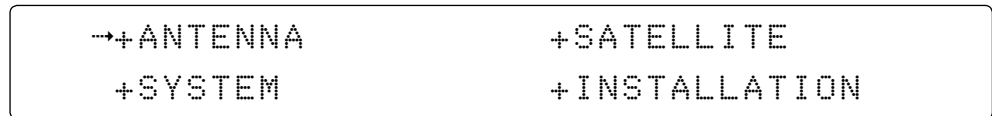

2. Press the OK key to enter **ANTENNA** menu.

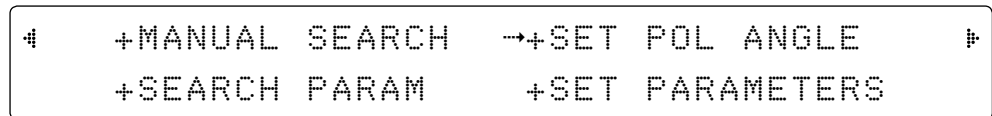

3. Press the RIGHT arrow key to move cursor to SET POL ANGLE and press OK key to enter **SET POL ANGLE** menu.

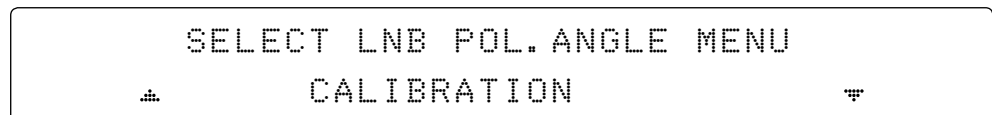

4. Press the UP and DOWN arrow keys to select the skew type and press the OK key to run the selected operation '**CALIBRATION**' or '**MANUAL ADJUST**'.
When you replace the control board, select CALIBRATION to calibrate LNB skew angle.

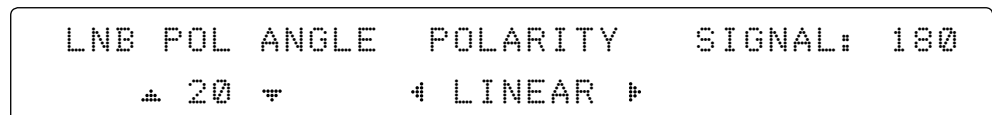

5. Press the UP and DOWN arrow keys to increase or decrease the LNB pol angle manually. Press BACK key to return to the main display.

6. Press the LEFT and RIGHT arrow keys to select the polarization between Linear and Circular. Press BACK key to return to the main display.

Setting Antenna Search Parameter

It is not recommended for a novice satellite service user to use this mode.

```

                SETUP MODE ?
      →YES                               NO
  
```

1. Press the LEFT key to move cursor to YES and press the OK key to enter setup mode.

```

→+ANTENNA          +SATELLITE
  +SYSTEM           +INSTALLATION
  
```

2. Press the OK key to enter **ANTENNA** menu.

```

#  +MENVUAL SEARCH  +SET POL ANGLE  #
  →+SEARCH PARAM    +SET PARAMETERS
  
```

3. Press the DOWN arrow key to move cursor to SEARCH PARAM menu and press the OK key to enter **SEARCH PARAM** menu.

```

# →SEARCH WAIT TIME  INCREMENT STEP  #
      020                1.0
  
```

4. Press the LEFT and RIGHT arrow keys to select the parameter you wish to edit. Or press the BACK key to return to the main display.

```

SEARCH WAIT TIME  INCREMENT STEP
  ▲      020      ▼                1.0
  
```

5. Set the **SEARCH WAIT TIME**. (Range : 20 - 120 sec)

Set the time-out for automatic initiation of a search after the signal level drops below threshold.

Press the LEFT and RIGHT arrow keys until the desired character is underscored (selected). Press the UP and DOWN arrow keys to increase and decrease the selected character Or press the NUMBER keys to set the desired value directly.

Press the OK key to set the **SEARCH WAIT TIME**.

Press the BACK key to save or abort and return to the main display.

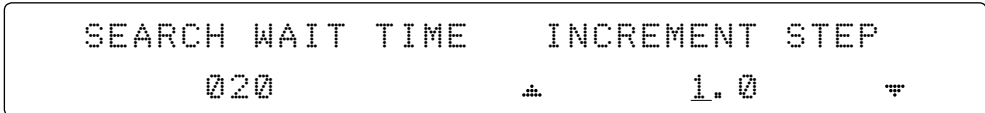

6. Set the **INCREMENT STEP** size.

Press the LEFT and RIGHT arrow keys until the desired character is underscored (selected). Press the UP and DOWN arrow keys to increase and decrease the selected character. Or press NUMBER keys to set the desired value directly.

Press the OK keys to set the **INCREMENT STEP**.
 Press the BACK key to save or abort and return to the main display.

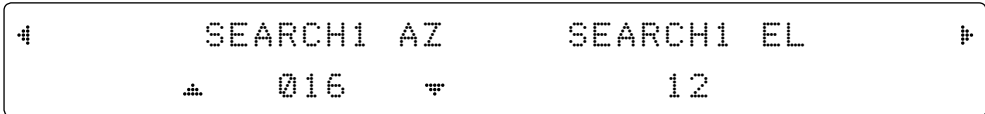

7. Set SEARCH 1, 2 and 3 AZ (Azimuth) range and EL (Elevation) range. SEARCH 1 is used for global search (without existence of heading data), while SEARCH 2 is used for non-global search (with heading data). If the desired signal is found, either SEARCH 1 or SEARCH 2 will automatically enter to SEARCH 3 mode.

A search pattern 1 or 2 will be initiated according to which GYRO TYPE is selected and the existence of the gyro input.

Search 1: A search pattern 1 will automatically be initiated when the ship's heading input does not exist/is failed. The antenna will go to the relative azimuth position 0° at the calculated elevation and search in the azimuth CCW direction and search up +0.5° & down -0.5° with a total 6°(±3°) in elevation. The search cycle will repeat until the antenna receives the lock signal from the satellite receiver or the DVB transponder of the target satellite is decoded by the antenna. If the desired signal is found and above the predefined detect level, the ACU will enter to Search 3.

Search 1 → Search 3: However, the antenna will not initiate Search 3 pattern but go into TRACKING mode immediately if the desired signal is above the predefined tracking threshold level. If the detected signal is below the predefined tracking threshold level, the search 1 will repeat and start 3° away from the current position.

Search 2: A search 2 pattern will automatically be initiated when AGC falls below the current threshold setting (indicates that satellite signal has been lost). Search is conducted in a two-axis pattern consisting of alternate movements in azimuth (AZ) and elevation. These parameters should only be changed by an authorized service technician. Improper setting of these parameters will cause your system to perform improperly. The search cycle will repeat until the antenna receives the lock signal from the satellite receiver or the DVB transponder of the target satellite is decoded by the antenna.

Search 2 → Search 3: If the desired signal is found and above the predefined detect level, the ACU will enter to Search 3. However, the antenna will not initiate Search 3 pattern but go into TRACKING mode immediately if the desired signal is above the predefined tracking threshold level.

If the detected signal is below the predefined tracking threshold level, the search 2 will repeat the search cycle.

Search 1 (Gyro Free) Search Pattern

Target Satellite EL Position

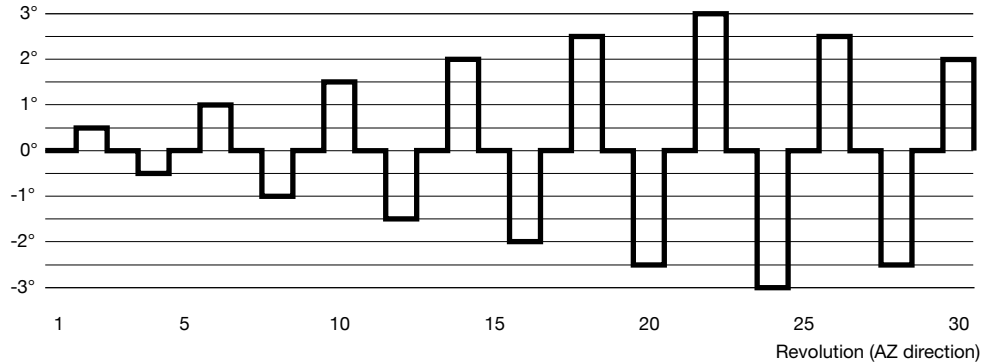

Search 1 antenna motion

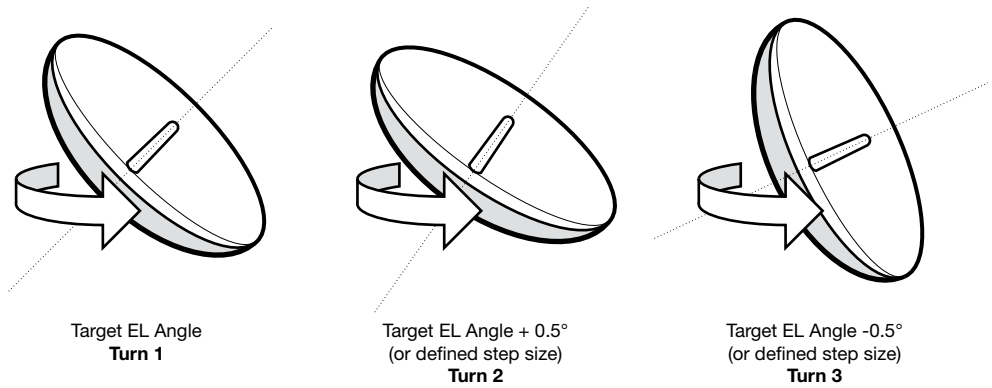

Search 3: A search pattern 3 will automatically be initiated after Search 1 or Search 2 mode. In Search 3 mode, the antenna will search for the target satellite by turning its azimuth angle directly to the position calculated using the ship’s heading input and lock onto the satellite. If the desired signal is found and above the predefined tracking level, the ACU will terminate Search 3 and go into TRACKING mode. Search is conducted in a two-axis pattern consisting of alternate movements in azimuth (AZ) and elevation (EL) as forming expanding square indicated as below diagram.

Search 3 pattern

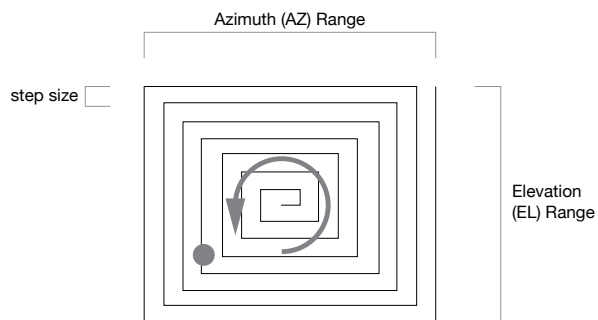

```

SEARCH1 AZ          SEARCH1 EL
  ▲    400        ▼          06
    
```

8. Set the **AZIMUTH RANGE**. (Range : 0 - 540)

Press the LEFT and RIGHT arrow keys until the desired character is underscored (selected). Press the UP and DOWN arrow keys to increase and decrease the selected character. Or press NUMBER keys to set the desired value directly. Press OK key to set the new **AZ RANGE**.

```

SEARCH1 AZ          SEARCH1 EL
      400          ▲    06    ▼
    
```

9. Set the **ELEVATION RANGE**. (Range : 0 - 90)

Press the LEFT and RIGHT arrow keys until the desired character is underscored (selected). Press the UP and DOWN arrow keys to increase and decrease the selected character. Or press NUMBER keys to set the desired value directly. Press OK key to set the new **EL RANGE**.

```

SEARCH3 AZ          SEARCH3 EL
  ▲    003        ▼          04
    
```

10. Press the OK key to set the Azimuth and Elevation ranges for SEARCH 2 in the same manner, then press the OK key.

```

                SAVE ?
      →YES                NO
    
```

11. Press the LEFT arrow key to move cursor to YES and press OK key to save and execute the current settings. Or press the RIGHT arrow key to move cursor to NO and press OK key to abort and return to the main display.

```

DETECT LEVEL   TRACKING LEVEL
  ▲   050     ▼           030

```

6. Set the **DETECT LEVEL**. (Range : 1-200)

The detect level is to set the satellite signal detection level.

Press the LEFT and RIGHT arrow keys until the desired character is underscored (selected). Press the UP and DOWN arrow keys to increase and decrease the selected character. Or press the NUMBER keys to set the new **DETECT LEVEL**. Or press the return key to return to the main display.

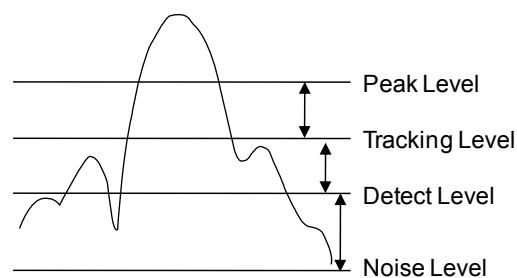

```

DETECT LEVEL   TRACKING LEVEL
           050     ▲           030     ▼

```

7. Set the **TRACKING LEVEL**. (Range : 1-200)

The tracking level is to set the satellite signal tracking level.

Press the LEFT and RIGHT arrow keys until the desired character is underscored (selected). Press the UP and DOWN arrow keys to increase and decrease the selected character. Or press the NUMBER keys to set the desired value directly. Press the OK key to set the new **TRACKING LEVEL**.



8. Set the **BOW OFFSET**. (Range : 0 -360)
The bow offset is to offset the angle difference between the antenna's bow and the ship's bow.

Press the LEFT and RIGHT arrow keys until the desired character is underscored (selected). Press the UP and DOWN arrow keys to increase and decrease the selected character. Or press the NUMBER keys to set the desired value directly. Press the OK key to set the new **BOW OFFSET**.



9. Set the **EL ADJUST**. (Range : ±5)
The elevation adjust is to offset the angle difference between the mechanical elevation angle and actual elevation angle.

Press the LEFT and RIGHT arrow keys until the desired character is underscored (selected). Press the UP and DOWN arrow keys to increase and decrease the selected character. Or press the NUMBER keys to set the desired value directly. Press the OK key to set the new **EL ADJUST**.

```
VOLT THRES.      SCAN OFFSET
  0650          55
```

11. Set the **VOLT THRES.**

The voltage threshold is to distinguish the voltage between 13V and 18V.

Press the LEFT and RIGHT arrow keys until the desired character is underscored (selected). Press the UP and DOWN arrow keys to increase and decrease the selected character. Or press the NUMBER keys to set the desired value directly. Press the OK key to set the new VOLT THRES.

```
VOLT THRES.      SCAN OFFSET
  0650          55
```

12. Set the **SCAN OFFSET.** (Range : 0 -90)

The scan offset is to offset the angle difference between the black marker on the sub-reflector and the optical sensor.

Press the LEFT and RIGHT arrow keys until the desired character is underscored(selected). Press the UP and DOWN arrow keys to increase and decrease the selected character. Or press the NUMBER keys to set the desired value directly.

Press the OK key to set the new SCAN OFFSET.

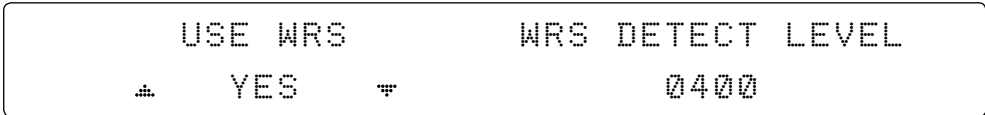

13. Set the **USE WRS**.
 USE WRS is to determine whether the system uses WRS LEVEL or not.
 USE WRS and WRS LEVEL are pair functions.
 Press the UP and DOWN arrow keys to select "YES" to USE WRS or "NO" to NOT USE WRS and press the OK key to set the **USE WRS**.

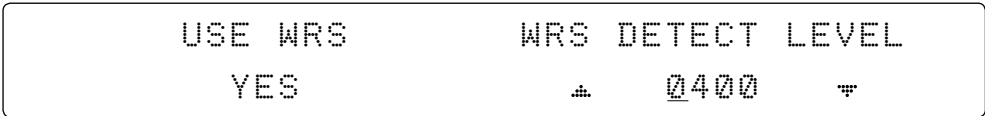

14. Set the **WRS DETECT LEVEL** (Range : 10 - 5,000)
 The WRS level is to set the WRS detection level.

 Press the LEFT and RIGHT arrow keys until the desired character is underscored (selected). Press the UP and DOWN arrow keys to increase and decrease the selected character. Or press the NUMBER keys to set the desired value directly. Press the OK key to set the new **WRS DETECT LEVEL**.



15. Set the **USE OFFSET**.
 USE OFFSET is to determine whether the system uses OFFSET DIFF or not.
 USE OFFSET and OFFSET DIFF are pair functions.
 Press the UP and DOWN arrow keys to select "YES" to USE OFFSET or "NO" to NOT USE OFFSET and press the OK key to set the **USE OFFSET**.

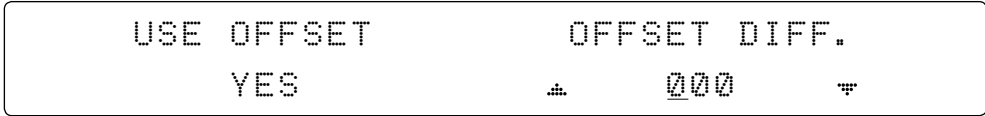

16. Set the **OFFSET DIFF.** (Range : ±100)
 The offset difference is to offset the signal difference between RHCP and LHCP.

 Press the LEFT and RIGHT arrow keys until the desired character is underscored (selected). Press the UP and DOWN arrow keys to increase and decrease the selected character. Or press the NUMBER keys to set the desired value directly. Press the OK key to set the new **OFFSET DIFF.**



17. Select operation process.

Press the UP and DOWN arrow keys to select the command from **OPERATION***.

OPERATION*

- **SAVE:** save and execute the current settings.
- **REBOOT:** the antenna will restart automatically if REBOOT is selected.
- **RATESENSOR BIAS:** rate sensor bias is to calibrate DC voltage output from the three rate sensors used to sense antenna motion in azimuth, elevation and cross-level axes.
The DC voltage output from each of the rate sensors may vary by an amount which is directly proportional to the direction and rate of motion induced on it. The motion of the ship must be stable when the sensor box is replaced.
- **TILT BIAS:** TILT BIAS is to adjust the two solid-state tilt sensors used to provide absolute cross-level tilt of the antenna and elevation feedback to eliminate long-term pointing drift (error). The TILT BIAS is required to be set when the system is newly installed or when the antenna control board or sensor box is replaced. Check and see if the bubble is located at the center of the level vial. If not, touch OK key to enter TILT BIAS menu to adjust it.



```
STEP SIZE  ELEVATION  CROSS LEVEL
#  0.2  #  ▲ 000.0  ▽  4 01.0  ▶
```

18. Press the NUMBER keys to set the step size.
Press the OK keys to select the parameter you wish to edit.
Press the LEFT and RIGHT arrow keys to move **CROSS LEVEL OFFSET** by step size. Press the UP and DOWN arrow keys to move **ELEVATION OFFSET** by step size.

```
SAVE ?
→YES  NO
```

19. Press the BACK key to save or abort and return to the main display.

```
DIAGNOSTIC      COMMUNICATION
┌ CODE 101 ── RESULT : PASSED
```

6. The diagnosis result is shown.

Diagnosis Code :

- CODE 101 : The data communication between the antenna and the ACU is tested.
- CODE 102 : The azimuth motor is tested.
- CODE 103 : The elevation motor is tested.
- CODE 104 : The cross-level motor is tested.
- CODE 105 : The azimuth encoder is tested.
- CODE 106 : The cross-level encoder is tested.
- CODE 107 : The rate sensor is tested.
- CODE 108 : The tilt sensor is tested.
- CODE 109 : The sensor box motor is tested.
- CODE 110 : The LNB is tested.
- CODE 111 : The LNB skew motor is tested.
- CODE 112 : The sub-reflector is tested. (Skip in the s80HD)
- CODE 113 : The antenna power is tested.
- CODE 114 : The ACU power is tested.
- CODE 115 : The receiver power is tested.

Test Result : ● 2 ●● - ●●●●●●●●●●

● : passed the test, - : skipped the test, ? : is still under processing
Refer 2 to the diagnosis code 102 as shown above for occurred error explanation.

Satellite Settings

Setting the Satellite Pair

```

                SETUP MODE ?
        →YES                               NO
  
```

1. Press the LEFT arrow key to move cursor to YES and press the OK key to enter setup mode.

```

+ANTENNA                →+SATELLITE
+SYSTEM                  +INSTALLATION
  
```

2. Press the RIGHT arrow key to move cursor to **SATELLITE** and press the OK key to enter **SATELLITE** menu.

```

#  →+SET SAT. PAIR      +EDIT SATELLITE  #
      +SET REGION        +FIND TRANSPONDER
  
```

3. Press the OK key to enter **SET SAT. PAIR** menu.

```

                SET TRIPLE SAT ?
        →YES                               NO
  
```

4. Move cursor to YES and press the OK key to enter **Tri-Sat mode** or move cursor to NO and press the OK key to enter **Dual-Sat mode**.

```

        PRESET SLOT          DEST. SATELLITE
        ⤴ PRESET 1 ⤵          DTV101
  
```

5. Press the UP and DOWN arrow keys to select **PRESENT SLOT 1, 2 and 3** in **Tri-Sat mode** or **1 and 2** in **Dual-Sat mode**.

PRESET SLOT	DEST. SATELLITE
PRESET 1	▲ DTV101 ▼

6. Press the UP and DOWN arrow keys to select the **DESTINED SATELLITE** from the library (pre-programmed satellites). Press the OK key to set the **DESTINED SATELLITE**.

SAVE ?	
→YES	NO

7. Press the BACK key to save the current settings or abort and return to the main display.

Edit Satellite Information

It is possible to modify the existing satellite information and input new satellite information into the ACU as well. It is not recommended for a novice satellite service user to use this mode.

```

                SETUP MODE ?
          →YES                NO
    
```

1. Press the LEFT arrow key to move cursor to YES and press the OK key to enter setup mode.

```

+ANTENNA                →+SATELLITE
+SYSTEM                  +INSTALLATION
    
```

2. Press the RIGHT arrow key to move cursor to SATELLITE and press the OK key to enter **SATELLITE** menu.

```

#  +SET SAT. PAIR      →+EDIT SATELLITE  #
  +SET REGION          +FIND TRANSPONDER
    
```

3. Press the RIGHT arrow key to move cursor to EDIT SATELLITE and press the OK key to enter **EDIT SATELLITE** menu.

```

                SELECT SATELLITE TO EDIT
                   ▲      DTV101      ▼
    
```

4. Press the UP and DOWN arrow key to select the satellite that you wish to edit and press the OK key to edit the selected satellite.

```

#  →LONGITUDE                EDIT NAME  #
   101.0W                    DTV101
    
```

5. Press the RIGHT and LEFT arrow keys to select the parameter that you wish to edit. Press the OK key to edit parameter.
Press the BACK key to save or abort and return to the main display.

```
LONGITUDE          EDIT NAME
  101.0W          DTV101
```

6. Set the **SATELLITE LONGITUDE**.
Press the LEFT and RIGHT arrow keys until the desired character is underscored (selected). Press the UP and DOWN arrow keys to increase or decrease the value. Or, press the NUMBER keys to set the desired value directly.
Press the OK key to set the SATELLITE LONGITUDE.

```
LONGITUDE          EDIT NAME
  101.0W          DTV101
```

7. Set the **SATELLITE NAME**.
Press the LEFT and RIGHT arrow keys until the desired character is underscored (selected). Press the UP and DOWN arrow keys to increase or decrease the value. Or, press the NUMBER keys to set the desired value directly.
Press the OK key to set the **SATELLITE NAME**.

```
VERIFY TYPE       VOLTAGE
  DVB DECODE     AUTO
```

8. Set the satellite **VERIFICATION TYPE**.
Press the UP and DOWN arrow keys to select the **Verification Method*** while the antenna is tracking the satellite signal and press the OK key to set the **VERIFY TYPE**.

```
VERIFY TYPE       VOLTAGE
  DVB DECODE     AUTO
```

9. Set the **LNB VOLTAGE**.
Press the UP and DOWN arrow keys to select the **LNB Voltage Supply Method*** and press the OK key to set the **VOLTAGE** ("AUTO" is recommended).

```

      DISEQC                                POL TYPE
      ▲   AUTO                               ▼   CIRCULAR
    
```

10. Set the **DISEQC**.

Press the UP and DOWN arrow keys to select **DiSEqC Method*** and press the OK key to set the **DISEQC** ("AUTO" is recommended).

```

      DISEQC                                POL TYPE
      AUTO                                     ▲   CIRCULAR   ▼
    
```

11. Set the **POL TYPE** manually.

Press the UP and DOWN arrow keys to manually select LINEAR or CIRCULAR and press the OK key to set the **POL TYPE**.

```

      LOCAL FREQUENCY
      ▲  10500  ▼
    
```

12. Set **LOCAL FREQ**.

Press the UP and DOWN arrow keys to select the LNB local frequency from the installed LNB. Or press the NUMBER keys to set the desired value directly. Press the OK key to set the parameter.

```

      VL   FREQ.                               SYMBOL                               NID
      ▲  11747MHz ▼  21300kSpS                0x00AD
    
```

12-1. Set the satellite **FREQUENCY** for VL(Vertical/RHCP Low) band.

Press the LEFT and RIGHT arrow keys until the desired character is underscored (selected). Press the UP and DOWN arrow keys to increase or decrease the value. Or press the NUMBER keys to set the desired value directly. Press the OK key to set the **FREQUENCY**.

```

VL      FREQ.      SYMBOL      NID
      12224MHz    20000kSpS  0x00AD
    
```

12-2. Set the frequency **SYMBOL** rate (Maximum: 45,000).
 Press the LEFT and RIGHT arrow keys until the desired character is underscored (selected). Press the UP and DOWN arrow keys to increase or decrease the value. Or press the NUMBER keys to set the desired value directly.
 Press the OK key to set the **SYMBOL**.

```

VL      FREQ.      SYMBOL      NID
      12224MHz    20000kSpS  0x00AD
    
```

12-3. Set the frequency NID (Network ID). Range is 0x0000-0xFFFF.
 Press the LEFT and RIGHT arrow keys until the desired character is underscored (selected). Press the UP and DOWN arrow keys to increase or decrease the value. Or press the NUMBER keys to set the desired value directly.
 Press the OK key to set the **NID**.

```

HL      FREQ.      SYMBOL      NID
      12450MHz    27490kSpS  0x00AD
    
```

13. Press the OK key to set the satellite frequency, symbol rate and NID for HL(Horizontal/LHCP Low) band in the same manner.
 Continue to press the OK key to set the satellite frequency, symbol rate and NID for VH (Vertical/RHCP High) and HH (Horizontal/LHCP High) in sequence.

Verification Method*

AGC - use signal level for satellite tracking.

DVB LOCK - use DVB Lock for satellite tracking.

DVB DECODE - use DVB Decode for satellite tracking.

DSS DECODE - use DSS Decode for satellite tracking.

Voltage Supply Method*

AUTO - supply 13V or 18V to LNB.

ONLY 13V - always supply 13V to LNB.

ONLY 18V - always supply 18V to LNB.

DiSEqC Method*

AUTO - supply 0KHz or 22KHz to LNB.

ONLY 0KHz - always supply 0KHz to LNB.

ONLY 22KHz - always supply 0KHz to LNB.

```

→SELECT CONTINENT      SELECT REGION
      N AMERICA          ▲  LOS_ANGELES ▼
    
```

6. Set the **REGION**.

Press the UP and DOWN arrow keys to select the region you are in.

Press the OK key to set the **REGION**.

```

                                LOAD ?
      →YES                                NO
    
```

7. Press the BACK key to load the current setting or abort and return to the main display.

```

LOADING . . .      ●●●○○○○○○○○○○○○○○○○
DO NOT TURN OFF !
    
```

8. Setting is being loaded to the system.

The ACU will restart the system automatically after uploading the setting.

DO NOT turn off ACU power while uploading is being processed.

```

+ SEARCH      [→] DTV101      +
                [2] DTV119
    
```

11. Region information has been updated.

Finding the Transponder

```
                SETUP MODE ?
          ←YES                               NO
```

1. Press the LEFT arrow key to move cursor to YES and press the OK key to enter setup mode.

```
+ANTENNA                →+SATELLITE
+SYSTEM                  +INSTALLATION
```

2. Press the RIGHT arrow key to move cursor to **SATELLITE** and press the OK key to enter **SATELLITE** menu.

```
+SET SAT. PAIR          +EDIT SATELLITE
+SET REGION             →+FIND TRANSPONDER
```

3. Press the DOWN arrow key and the OK key to enter **FIND TRANSPONDER** menu.

```
        BAND                FREQ.                SYMBOL
┌ VER LOW ▾                12224MHz                20000kSp s
```

4. Press the UP and DOWN arrow keys to select the frequency band you wish you edit. Press the OK key to edit the selected frequency.

```

      BAND          FREQ.          SYMBOL
VER LOW   ▲ 12224MHz ▼ 20000kSpS

```

5. Set the satellite **FREQUENCY**.

Press the LEFT and RIGHT arrow keys until the desired character is underscored (selected). Press the UP and DOWN arrow keys to increase or decrease the value. Or press the NUMBER keys to set the desired value directly.

Press the OK key to set the **FREQUENCY**.

```

      BAND          FREQ.          SYMBOL
VER LOW          12224MHz   ▲ 20000kSpS ▼

```

6. Set the frequency **SYMBOL RATE**.

Press the LEFT and RIGHT arrow keys until the desired character is underscored (selected). Press the UP and DOWN arrow keys to increase or decrease the value. Or press the NUMBER keys to the desired value directly.

Press the OK key to set the **SYMBOL**.

```

◄ [CHECK NID] F: 12224 S: 27490×FFF0 ►
PRESS OK RECEIVED NID [0×0000]

```

7. CHECK NID is to verify the NID (Network ID) of the current tracking transponder. Press the OK key to verify the NID [0 x 0000] only when "PRESS OK" function is activated. "PRESS OK" function will only be activated when DVB Lock signal is confirmed by the antenna. However, "NO LOCK" message will be displayed if DVB Lock signal can't be confirmed.

8. Press BACK key to return to the main display.

System Settings

Setting the GPS and Gyrocompass

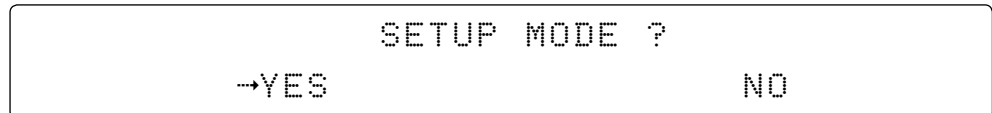

1. Press the LEFT arrow key to move cursor to YES and press the OK key to enter setup mode.



2. Press the DOWN arrow key to move cursor to SYSTEM and press the OK key to enter **SYSTEM** menu.

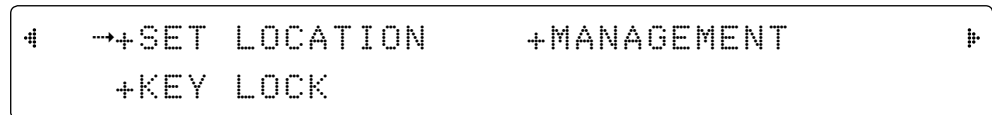

3. Press the RIGHT arrow key to move cursor to SET LOCATION and press the OK key to enter **SET LOCATION** menu



4. Set the ship's GYRO TYPE* and BAUD RATE
A search pattern 1 or 3 will be initiated according to which GYRO TYPE is selected and the existence of the gyro input. Set the BAUD RATE as 4800, 9600, 19200 or 38400 according to your device.

A search pattern 1 will be initiated automatically if the gyro input does not exist and the gyro type is selected other than GROUND TEST.

NOTE: The bow offset will not be saved automatically if Search 1 pattern is initiated. In this case, the antenna will need to re target the desired satellite using Search 1 every time if the antenna restarts.

Setting of Heading Device			
Existence of Heading Data	None	NMEA / NMEA 2000	Ground Test
With Heading Data	Search 1	Search 2	Search 2
Without Heading Data	Search 1	Search 1	Search 2

GYRO TYPE*
 NO DEVICE
 NMEA
 NMEA 2000
 GROUND TEST

```

┌────────────────────────────────────────────────────────────────────────────────┐
│  ← →+LATITUDE                                +LONGTITUDE                    │
│                                     37.07N                                127.05E  │
└────────────────────────────────────────────────────────────────────────────────┘

```

5. Press the LEFT AND RIGHT arrow keys to select the parameter you wish to edit. Or press the BACK key to return to the main display.

```

┌────────────────────────────────────────────────────────────────────────────────┐
│                                     LATITUDE                                LONGTITUDE  │
│  ▲  37.07N  ▼                                127.05E                    │
└────────────────────────────────────────────────────────────────────────────────┘

```

6. Set the current **LATITUDE**.
 Press the LEFT and RIGHT arrow keys until the desired character is underscored (selected). Press the UP and DOWN arrow keys to increase or decrease the value. Or press the NUMBER keys to set the desired value directly.
 Press the OK key to set the **LATITUDE**.

```

┌────────────────────────────────────────────────────────────────────────────────┐
│                                     LATITUDE                                LONGTITUDE  │
│  37.07N                                ▲  127.05E  ▼                    │
└────────────────────────────────────────────────────────────────────────────────┘

```

7. Set the current **LONGITUDE**.
 Press the LEFT and RIGHT arrow keys until the desired character is underscored (selected). Press the UP and DOWN arrow keys to increase or decrease the value. Or press the NUMBER keys to set the desired value directly.
 Press the OK key to set the **LONGITUDE**.



8. Set the ship's current **HEADING**.

Entry of ships heading is not required when your system is connected to a NMEA0813 Heading Gyro Compass output.

Press the LEFT and RIGHT arrow keys until the desired character is underscored (selected). Press the UP and DOWN arrow keys to increase or decrease the value. Or press the NUMBER keys to set the desired value directly. Press the OK key to set the **HEADING**.

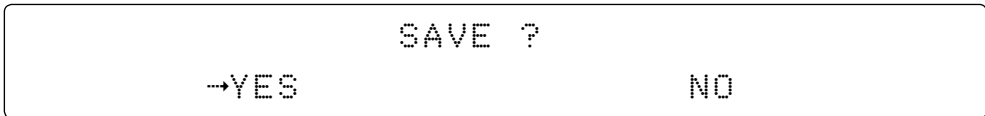

9. Press the LEFT arrow keys to move cursor to YES and press the OK key to save current setting. Or move cursor to NO and press the OK key to return to the main display.

System Management

```

                SETUP MODE ?
          →YES                               NO
    
```

1. Press the LEFT arrow key to move cursor to YES and press the OK key to enter setup mode.

```

      +ANTENNA                               +SATELLITE
    →+SYSTEM                               +INSTALLATION
    
```

2. Press the DOWN arrow key to move cursor to SYSTEM and press the OK key to enter **SYSTEM** menu.

```

#  +SET LOCATION  →+MANAGEMENT  #
  +KEY LOCK
    
```

3. Press the ARROW key to move cursor to MANAGEMENT and press the OK key to enter **MANAGEMENT** menu.

```

                SELECT PROCESS TYPE
          ▲                BACKUP USER DATA                ▼
    
```

4. Press the UP and DOWN arrow keys to **SELECT PROCESS TYPE***. Press the OK key to set the parameter and the processing message will be displayed.

```

                BACKUP ANTENNA PARAMETERS ?
          →YES                               NO
    
```

5. Press the LEFT and RIGHT arrow keys to select YES or NO to process selected process type.

```

    BACKUP AND INFO
    DO NOT TURN OFF ! ●●●○○○○○○○○○○○○○○○○○○○○
    
```

6. Processing message is displayed.

SELECT PROCESS TYPE*

BACKUP USER DATA: To backup the antenna settings set by user to the ACU.

RESTORE USER DATA: To restore the antenna by using the backup user data stored from the ACU.

DEFAULT ACU-REMOTE P/W: to default ID and Password of the Web Server.

UPGRADE FROM USB: to upgrade the system by using the firmware files from a specified folder in the USB flash drive.

COPY LOG TO USB: to copy the antenna log data from the system to the USB flash drive.

BACKUP TO USB: To backup the antenna settings to a specified folder in the USB flash drive.

RESTORE FROM USB: To restore the antenna by using the backup user data from a specified folder in the USB flash drive.

UPGRADE ACU-REMOTE: To upgrade the system using the Remote Access firmware file (ETSW-fs-XXX.bin) from a specified folder in the USB flash drive.

NOTE: UPGRADE FROM USB, COPY LOG TO USB, BACKUP TO USB, RESTORE FROM USB and UPGRADE ACU-REMOTE options are displayed only if the USB flash drive is plugged into the USB port located in the front panel of the ACU.

Key Lock

```

                SETUP MODE ?
          →YES                               NO
  
```

1. Press the LEFT arrow key to move cursor to YES and press the OK key to enter setup mode.

```

    +ANTENNA                               +SATELLITE
    →+SYSTEM                               +INSTALLATION
  
```

2. Press the DOWN arrow key to move cursor to SYSTEM and press the OK key to enter **SYSTEM** menu.

```

    †   +SET LOCATION                       +MANAGEMENT   †
    →+KEY LOCK
  
```

3. Press the RIGHT arrow key to move cursor to KEY LOCK and press the OK key to enter **KEY LOCK** menu.

```

                KEY LOCK
          ▲  OFF  ▼
  
```

4. Press the UP and DOWN arrow keys to choose whether or not to use key pad lock when entering the SETUP mode or saving the satellite information.

```

    KEY LOCK                               UNLOCK P/W
      ON                                   ▲  1590  ▼
  
```

5. Setup the password for entering the key pad lock. The factory default is 1590.

PC CONTROLLER SOFTWARE

PC to ACU Communication Setup

Toolbar Menus

System Property Status Dashboard

Work View Tabs

Antenna - Basic Info.

Antenna - Advanced Info.

Satellite (Satellite View)

Graph View

Monitor

ACU System

PC to ACU Communication Setup

Starting Aptus®

Double-click the Aptus® desktop icon, then Communication Window appears to establish the data communication between your PC and the ACU. Select options of connection method to access your ACU either through the Serial Port Communication or the Network Communication (TCP/IP).

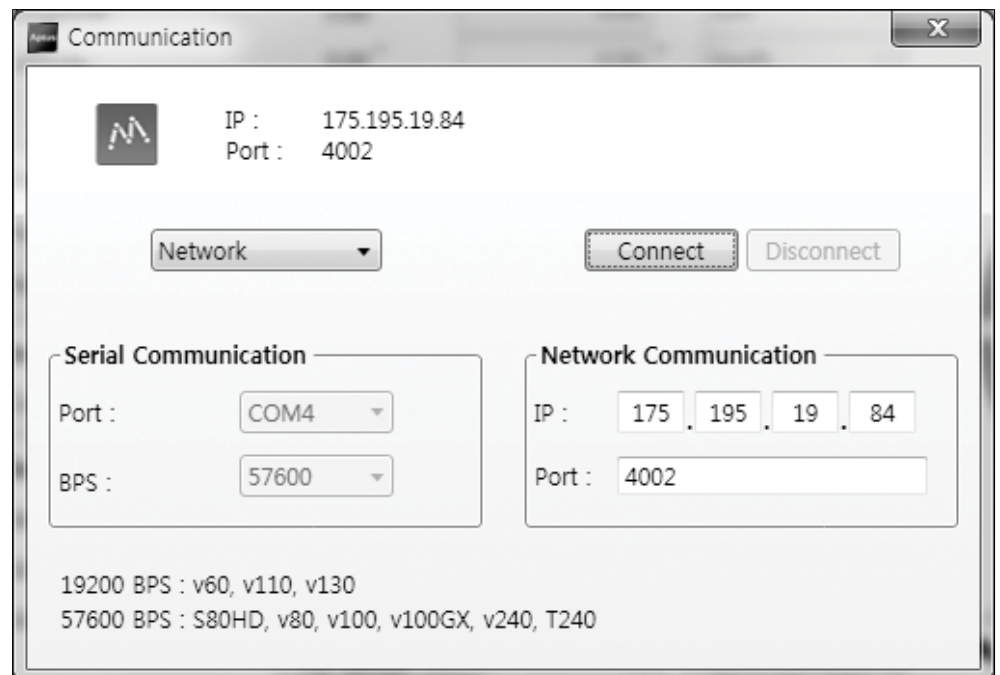

Establish a data communication

Access ACU through Serial Communication

1. Connect a 9 pin Serial cable between the PC INTERFACE connector on the ACU and the 9 pin Serial port on the PC. (Or you can use a USB cable to setup Serial connection between a PC and the USB port on the ACU.)
2. Select Serial at communication type combo-box.
3. The baud rate of the ACU is 57600 for the s80HD.
4. Select a COM port which is not occupied by other devices.
5. Click the Connect button.

Access ACU through Network Communication (TCP/IP)

1. Turn off the wireless connection while using this method.
2. Connect your PC to the Management Port.
3. Select Network at communication type combo-box.
4. Enter in the ACU's IP address (Factory default : 192.168.2.1)
5. Enter in the ACU's port number (Factory default : 4002)
 - Enter 4003 for SSL Secure Connection.
6. Click the Connect button then the Authentication window will appear.
7. Login by using the username and password below:
 - Username: intellian (Factory default)
 - Password: 12345678 (Factory default)

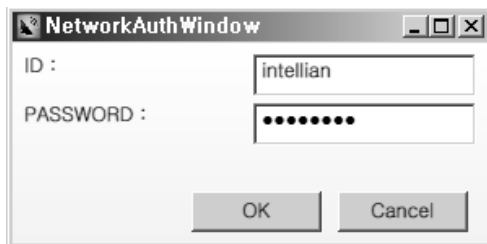

NOTE: If the remote access PC is located in the same network group with the ACU, the ACU can be accessed through the internal IP address. But, if the remote access PC is located outside of the network group, the ACU's IP address should be changed to the IP address assigned by the network service provider.



WARNING:

- Do not plug a USB to the ACU while TCP/IP communication is in use. Doing so will disable current PC Software Control because the USB connection has higher priority than TCP/IP connection.
- The amount of data will increase rapidly if Network Communication is in use. Intellian recommends using Remote Web Access (Web M&C) to access the ACU.

Toolbar Menus

The toolbar menus at the top of the screen display command buttons of the most commonly used functions of the Aptus®. The toolbar menu consists of 4 main menus; Quick (for quick launch of functions), File (for file backup, restoring and loading), View and Connection.

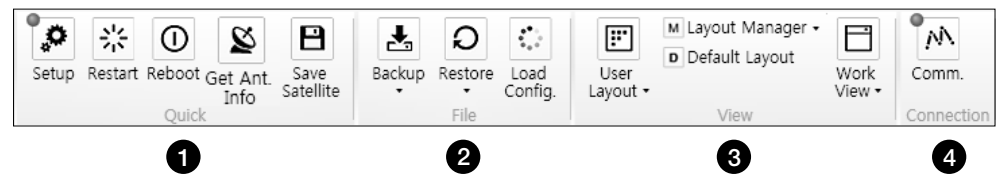

① Quick



Setup: enters Setup mode.



Restart: exits Setup mode and restarts the antenna.



Reboot: reboots the antenna.



Get Ant. Info: obtains the information stored in the antenna



Save Satellite: saves the current bow offset only if the antenna is tracking onto the satellite. The satellite acquisition time can be reduced significantly after the antenna is restarted.

② File



Backup: backups the antenna information to ACU or PC.

- Select 'To ACU' to backup the antenna information to ACU. The backup file (file format: *.ibf) will be stored on the ACU.

- Select 'To PC' to backup the antenna information to a PC. The backup files (file format: *.rpt and *.ibf) will be generated on the PC.

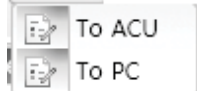

NOTE: Both *.rpt and *.ibf files contain antenna information. However, while *.ibf file can be used for restoring antenna information, *.rpt file is stored as plain-text for viewing purpose only. Users can open the *.rpt using text editors such as notepad software.



Restore: restores the antenna by using the stored information in ACU or PC.

- Select 'From ACU' to restore the antenna by using the stored information in ACU.

- Select 'From PC' to restore the antenna by using the stored information in PC (file format: *.ibf).

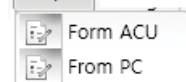

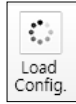

Load Config. : loads the antenna configuration file (file format: *.cfg). The configuration file includes the antenna control parameters which are pre-loaded at the factory and should only be changed by an authorized service technician. Improper setting of these parameters will cause your system to perform improperly.

③ View



- **User Layout:** displays the layout list that the user has previously stored by using Layout Manager. If you select a layout in this list, the selected layout will be constructed in Work View screen. The 'Basic layout' is provided by default.

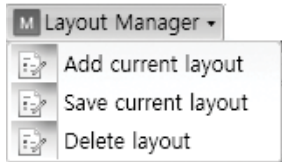

- **Layout Manager:** provides the user with add, delete, and save functionalities in order to manage the user's layouts.
 - Selecting 'Add current layout' opens a pop up window. Type in a desired name of current layout and click Add, then the new name of the current layout will be saved to the list under User Layout menu.
 - When changes are made to the current layout, select 'Save current layout' option. The current layout will be saved with changes.
 - To remove a layout, select 'Delete layout' option. Select a desired layout to remove on the pop up window, then click 'Delete'. Close the window by clicking on 'Close'. The selected layout is removed from the User Layout list.

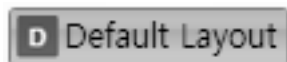

- **Default Layout:** returns the current layout to the default layout.

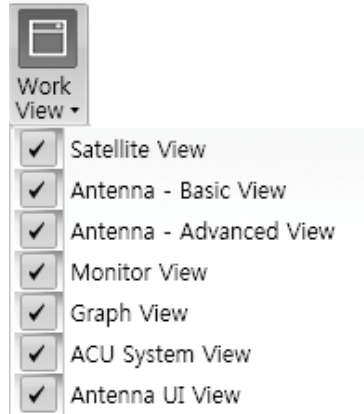

- **Work View:** displays a list of seven pre-constructed Work View Tabs (Satellite View, Antenna Basic View, Antenna Advanced View, Monitor View, Graph View, ACU System View, and Antenna UI View) and also provides the Activate / Close functionalities for each view tab. Activate the work view tab by ticking the checkbox next to it.

④ Connection



At any time, data communication channel can be re-established between Serial and Network connection. Selecting Comm. Button will display Communication Window to connect to the ACU via Serial or Network communication.

System Property Status Dashboard

The property status dashboard on the left pane of the screen provides the antenna status, the availability of TX transmission, signal level, GPS and heading status, software information, product information and error status to be monitored quickly.

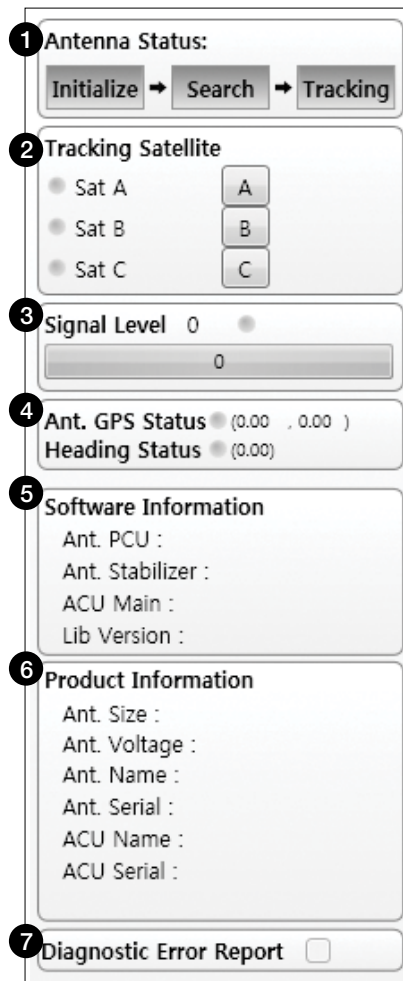

- ① Antenna Status: Displays the status of the current mode of the antenna.
- **Search 1:** A Search 1 pattern will automatically be initiated when the ship's heading input does not exist or if it fails. The search cycle will repeat until the antenna receives the lock signal from the receiver or until the DVB transponder of the target satellite is decoded by the antenna.
 - **Search 2:** A search 2 pattern will automatically be initiated when the AGC falls below the current threshold setting (indicates that satellite signal has been lost). Search is conducted in a two-axis pattern consisting of alternate movements in azimuth (AZ) and elevation. The search cycle will repeat until the antenna receives the lock signal from the satellite receiver or the DVB transponder of the target satellite is decoded by the antenna.

- **Search 3:** Search 3 pattern will automatically be initiated when AGC falls below the current tracking level threshold value. Once the desired signal is found and above the predefined tracking threshold, the ACU will enter to tracking mode.
- **Tracking:** Antenna is tracking the target satellite.
- **Initialize:** Antenna or ACU is initializing.
- **Setup:** Antenna is in SETUP mode.

② Tracking Satellite

Display or set current tracking satellite and tracking information. Up to three satellites can be selected.

③ Signal Level

Shows “DVB” when DVB mode of tracking signal is in use. The “Red” line indicates the signal “Detect Level Threshold” and the “Orange” line indicates the signal “Tracking Level Threshold”. If the signal level is higher than the tracking level threshold, the signal level bar will display “Blue” color. If the signal level is lower than the tracking level threshold, the signal level bar will display “Orange” color and the antenna will stay in searching mode.

NOTE: If the signal level is not higher than the tracking threshold, decrease the detect and tracking level.

④ GPS and Heading

Displays the current GPS location from the Antenna and Ship’s heading information. The status light flashes green if the system receives a correct input of the GPS and Ship’s heading.

Ant. GPS Status ● (127.05 E , 37.07 N)
Heading Status ● (0.00)

⑤ Software Information: Displays the antenna and the ACU firmware versions, and the library version.

Software Information
Ant. PCU : V 0.90
Ant. Stabilizer : V 0.90
ACU Main : V 9.00
Lib Version : V 1.01

⑥ Product Information: Displays the antenna and ACU serial numbers, antenna model and ACU model.

⑦ Diagnostic Error Report

The square button next to the Diagnostic Error Report turns red when the system receives an error. Click the button to see a Diagnostic Report.

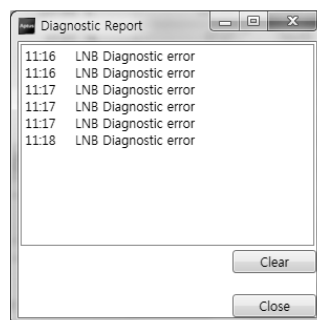

Work View Tabs

Aptus® provides seven Work View Tabs (Satellite View, Antenna Basic View, Antenna Advanced View, Monitor View, Graph View, ACU System View, and Satellite View) to manage the Antenna and the Satellite configuration.

How to modify the settings on Work View;



1. Enter the Setup mode by clicking Setup icon.

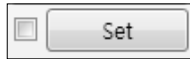

2. Tick the checkbox next to the “Set” button to modify the settings.
3. Enter the desired value then press the Set button to save the settings.

1. Antenna – Basic Info.

This view tab provides information on the Antenna’s Current GPS location, Heading Device, Bow Information, Skew Information, and the Antenna’s Angle. This view tab uses the Antenna’s AZ and EL information as well as the Ship’s Heading information in order to provide a dynamic graphic user interface (UI).

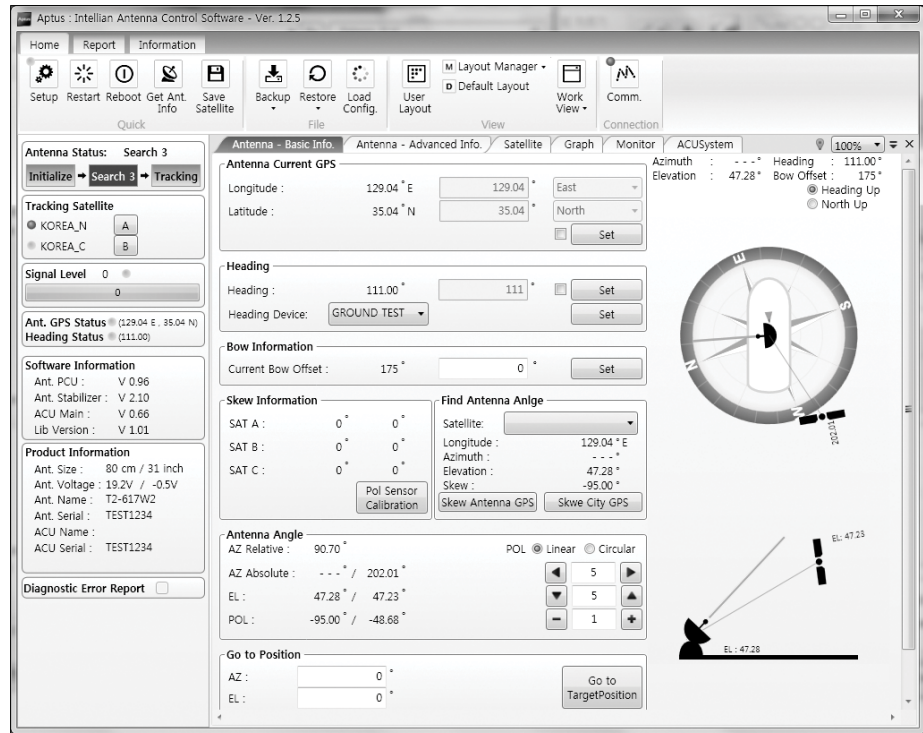

- **Antenna Current GPS:** displays and sets current antenna's GPS.
- **Heading:** displays and sets current ship's heading information.
 - Heading Device: None / NMEA/ NMEA 2000/Ground Test.
The baud rate (4800/ 9600/ 19200/ 38400) must be set if NMEA is selected.
- **Bow Information:** displays and sets current antenna's bow.
- **Skew:** displays current antenna's skew and skew offset for the selected satellites.
 - Pol Sensor Calibration: calibrates the sensor (potentiometer).
- **Find Antenna Angle:** displays and sets the current antenna angle. Select a desired satellite from the drop-down menu, then longitude, azimuth, elevation and skew information are displayed.
 - Skew Antenna GPS: Finds the current antenna angles and skew angle in relation to the longitude (orbit position) of the antenna's current GPS.
 - Skew City GPS: Finds the current antenna's angle and skew angle in relation to the longitude (orbit position) of the satellite and the city's GPS.
- **Antenna Angle:** displays and sets current antenna's absolute and relative AZ (azimuth) position, EL (elevation) position and polarization (between Linear and Circular). You can move antenna azimuth and elevation position and LNB Pol angle by using the arrows or inputting a value to find the desired satellite manually.
- **Go to Position:** The current position (angle) of the antenna is displayed. Push the "Go to target Position" button after keying in the desired angle to move the antenna to target position.

2. Antenna – Advanced Info.

This view provides information on the Tilt Sensor Bias, Rate Sensor, Conical Range, Parameter Setting, Threshold Setting, Search Parameter and Flag Setting.

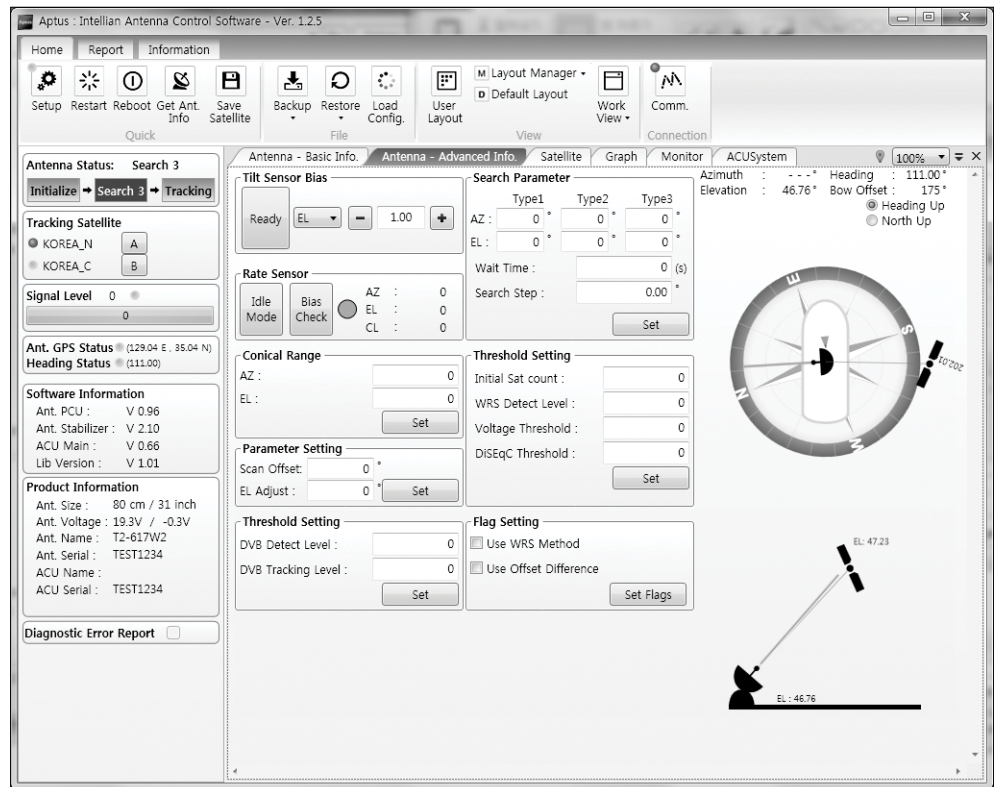

-Tilt Sensor Bias: This maintains the elevation and the cross level axes in order to keep the pedestal parallel to the horizon. Adjust the two solid-state tilt sensors to provide absolute cross-level tilt of the antenna and el elevation feedback to eliminate long-term pointing drift (error). Tilt bias must be adjusted when the antenna control board or sensor box is replaced. If the bubble on the button level located on the sensor box is not centered, follow the following steps to adjust the tilt sensor bias.

- Step 1. Enter Setup mode and press the “Ready” button to bring the elevation and cross-level to 0.
- Step 2. Select “EL” from the drop down list and press Up and Down arrow keys to adjust the bubble until it is located in the center ring of the button level.
- Step 3. Select “CL” from the drop down list and press Up and Down arrow keys to adjust the bubble until it is located in the center ring of the button level.



- Step 4. Press the “Restart” icon to restart the antenna.

- **Rate Sensor:** is used to calibrate the DC voltage output from the three rate sensors (azimuth, elevation, and cross-level). These are used to sense antenna motion that corresponds to the ship’s motion (roll, pitch, and yaw) for stabilizing the pedestal. The DC voltage output from each of the rate sensors may vary by an amount which is directly proportional to the direction and rate of motion induced on it.

Before calibrating the rate sensors located in the Sensor box, make sure that the antenna is placed on a rigid and flat platform. During the calibration process, any motion of the antenna should be avoided as it can affect the antenna’s performance. Proceed with the following steps to perform the calibration.

- Step 1. Enter Setup mode
- Step 2. Press the “Idle Mode” button to release the elevation and cross level motor brakes while the antenna is in Setup mode.
- Step 3. Check whether or not the bubble is located at the center of the button level. If not, move it to the center by following the previous instruction of Tilt Sensor Bias adjustment.
- Step 4. Press the “Bias Check” button to calibrate the rate sensor. A blue circle will be displayed next to the Bias Check button if the calibration is completed. A red circle will be displayed if calibration failed. A green circle will be displayed during the calibration process.

- **Conical Range:** The relative force of the motors controlling azimuth and elevation. Set the conical range while the antenna is in tracking mode.

- **Parameter Setting: used to set the control parameter settings.**

- Scan Offset: The scan offset is to offset the angle difference between the black marker on the sub-reflector and the optical sensor
- EL Adjust: The elevation adjustment is to offset the angle difference between the mechanical elevation angle and actual elevation angle.

- **Threshold Setting:** set the threshold level for detecting and tracking the satellite signal.

- DVB Detect Level: displays and sets signal detection threshold level when DVB tracking mode is in use.
- DVB Tracking Level: displays and sets signal tracking threshold level when DVB tracking mode is in use.

- **Search Parameter:**

- Wait time: set the time-out for automatic initiation of a search after the signal level drops below the pre-defined threshold value.
- Search Step: set increment step size.
- Type 1, Type 2 & Type 3 (Search 1, 2 & 3) Range: set Search 1, 2 & 3 search range. Search 2 and Search 3 are conducted in a two-axis pattern consisting of alternate movements in azimuth and elevation as it forms an expanding square.

- **Threshold Settings**

- Initial Sat Count: Set the threshold count for maintaining tracking.
- WRS Detect Level: Set the WRS detection level.
- Voltage Threshold: Set the voltage threshold. The voltage threshold is to distinguish the voltage between 13V and 18V.
- DiSEqC Threshold: Set the DiSEqC threshold. The DiSEqC threshold is to distinguish the 0KHz tone and 22KHz tone.

- **Flag Settings**

- Use WRS Method: Use WRS method is to determine whether the system uses “WRS Detect Level” or not. Use WRS method and “WRS Detect Level” are pair functions.
- Use Offset Difference: Use offset difference is to determine whether the system uses “Offset Difference” or not. Use Offset Difference and “Offset Difference” are pair functions.

3. Satellite (Satellite View)

The name, longitude, Skew Offset, Polarity, verification method of the satellite and local frequency are displayed. Tick the “Edit Satellite” box to edit the satellite information. After modifying the value.

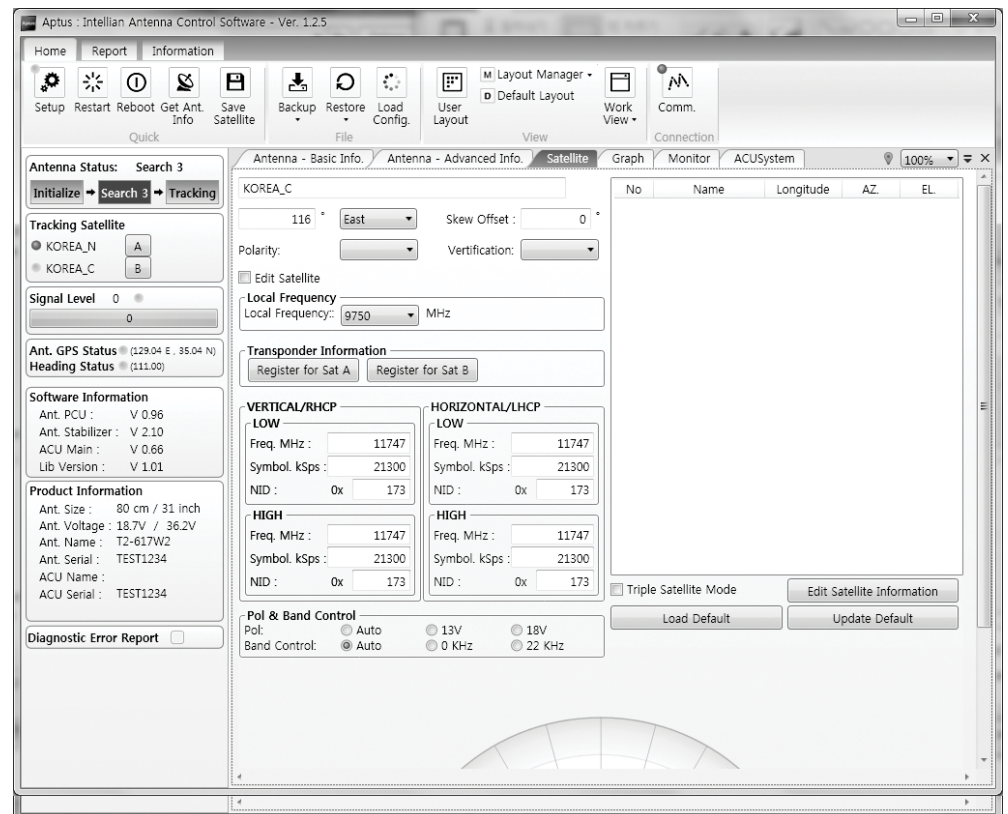

- **LNB Local Frequency:** Displays or sets LNB local frequency and its corresponding LNB voltage supplied. You may select pre-programmed LNB LO settings from the drop down list. This procedure is same for both the Intellian Global VSAT PLL LNB and any other LNB.

- Transponder Information

- Register for Sat A & Register for Sat B: register the selected satellite for A or B.
- Transponder information consists of frequency, symbol and NID (Network ID) of a transponder in tracking the satellite. There are four groups of transponder information. ‘Vertical/RHCP’ is applied when the IRD supplies 13V, and ‘Horizontal/LHCP’ is applied when the IRD supplies 18V. ‘LOW’ is applied when DiSEqC signal is not detected from IRD. ‘HIGH’ is applied when the DiSEqC signal is detected from the IRD. After modifying information, press the ‘Edit Satellite Information’ button, then new information is updated in the antenna.

- **Pol & Band Control:** The “Pol” controls 13V (Vertical/RHCP band) or 18V (Horizontal/ LHCP band). The “Band” controls DiSEqC 0KHz tone (Low band) and 22KHz tone (High band). After modifying information, press ‘Edit Satellite Information’ button, then new information is updated in the antenna.

- **Triple Satellite Mode:** To select between Dual-Sat mode and Triple-Sat mode, tick the 'Dual Satellite Mode' box or 'Triple Satellite Mode' box at the bottom of the screen.

- **Edit Satellite Information:** push the “Edit Satellite Information” button to update the information after modifying values.

- **Load Default:** Push the "Load Default" button to select a regional library file *.rif according to your region.

- **Update Default:** After loading a regional library file *.rif, push the "Update Default" button to update the system.

4. Graph View

This view provides information on Signal, Elevation (EL), Absolute AZ (Azimuth), Relative AZ, Heading, AZ and EL in Single or Multi graph formats.

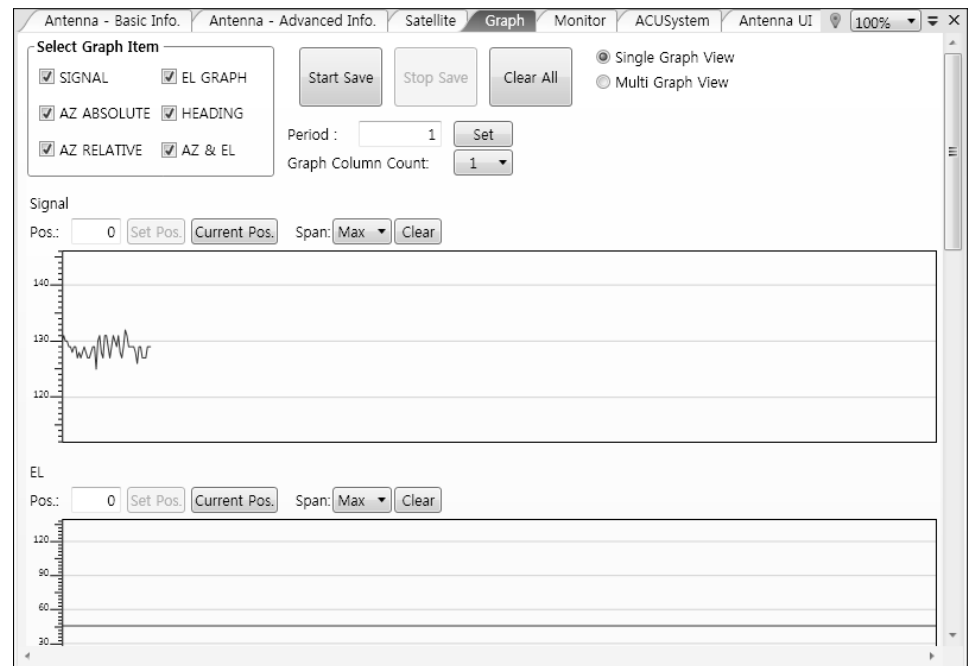

- **Select Graph Item:** shows the graphs of only the checked item(s) in a Single or Multi Graph View.
- **Single Graph View:** shows Graph Views per each single Graph Item selected in 'Select Graph Item'.
- **Multi Graph View:** shows one large integrated Graph View of multiple Graph Items selected in 'Select Graph Item'.
- **Start/Stop Save:** the chosen item is saved within the data log. The data log which stores the information displayed in the graphs can be later used for a service technician to find out a cause of any possible problem to the antenna.
- **Clear All:** clears everything drawn on the Graph View window.
- **Set Pos.:** sets the current position as center value of each Graph Item.
- **Current Pos.:** moves to the location according to values of each Graph Item.
- **Span:** sets the Display Range(s) of each corresponding Graph Item.
- **Period:** displays and sets the signal sampling rate.
- **Graph Column Count:** makes all Graph Views show in either one or two-column format.

5. Monitor

This view provides a UI which can monitor all data that has been received from the ACU.

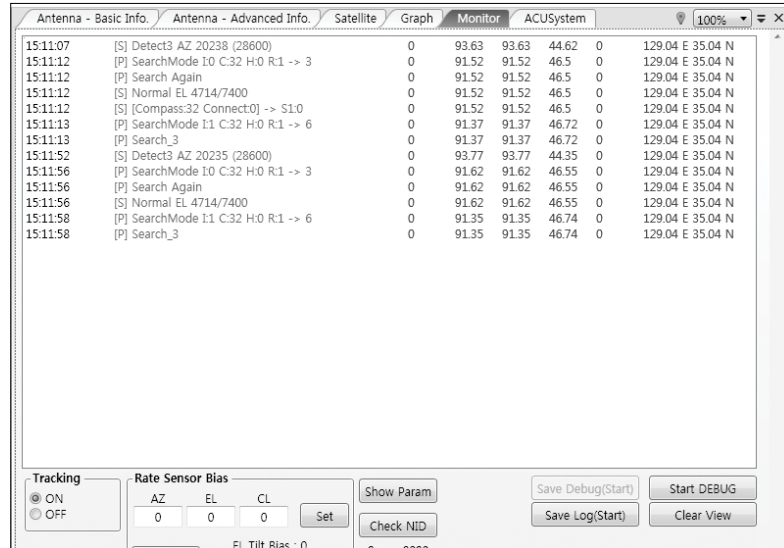

- **Tracking:** turns on or off the dish scan function. If the dish scan function is disabled, the antenna will stop adjusting the antenna pointing angle in order to optimize the receive signal level.
- **Rate Sensor Bias:** is used to calibrate the DC voltage output from the three rate sensors (azimuth, elevation, and cross-level). These are used to sense antenna motion that corresponds to the ship's motion (roll, pitch, and yaw) for stabilizing the pedestal. Push the "Check" button to check the EL and CL Tilt Bias.
- **Show Param:** shows the current antenna parameters.
- **Check NID:** verifies the NID (network ID) of the current tracking transponder. Press the NID button to obtain the NID only if the antenna is locked onto the desired satellite .
- **Debug (Start):** starts the debug log of the antenna. The debug message will be displayed once the debug button is pressed.
- **Stop Debug:** stops debug logging of the antenna.
- **Save Log (Start/Stop):** starts or stops the logs of the antenna. This button will be enabled while viewing the debug log. The log message will be stopped or be saved into a *.txt file once the log button is pressed. (V_Date.txt.)
- **Save Debug (Start/Stop):** starts or stops saving the debug log. This button is enabled once the Start Debug button is pressed.
- **Clear View:** clears the debug message or log data in monitoring window.

6. ACU System

This view provides Antenna Diagnostic Testing.

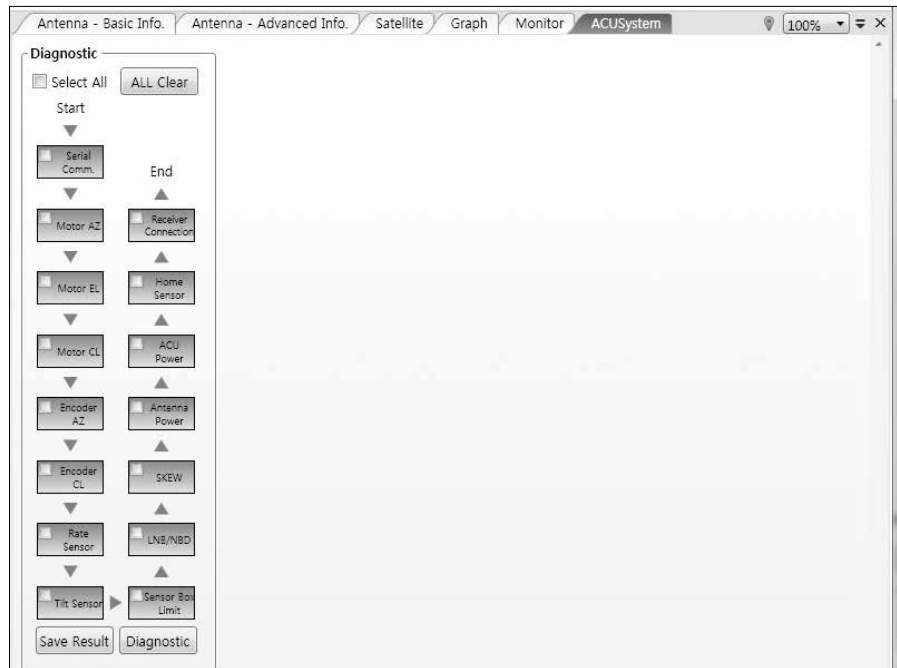

- **Diagnostic** : select to run a full diagnostic test or single diagnostic test. "Green" indicator is displayed for the test under progress. "Blue" indicates the test result as Pass while "Red" indicates the result as Fail. "Yellow" indicates the test has been skipped.

- **Serial Comm.:** tests the data communication between the antenna and the ACU.
- **Motor AZ:** tests the azimuth motor.
- **Motor EL:** tests the elevation motor.
- **Motor CL:** tests the cross-level motor.
- **Encoder AZ:** tests the azimuth encoder.
- **Encoder CL:** tests the cross-level encoder.
- **Rate sensor:** tests the rate sensor.
- **Tilt Sensor:** tests the tilt sensor.
- **Home sensor:** tests the home sensor.
- **ACU power:** tests the ACU power to see whether or not it is within the nominal operating range.
- **Receiver Connection:** tests the data communication between the antenna and the receiver.

- **Antenna power:** tests the antenna power to see whether or not it is within the nominal operating range.
- **Skew:** tests the LNB skew motor.
- **LNB/ NBD:** tests the LNB. (NBD is not available on this model.)
- **Sensor Box Limit:** tests the sensor box motor .

7. Work View Functions

The seven Work View Tabs displayed in the Work View can be arranged in customized layouts.

- Layout Formatting

- Each of the Work View Tab can be separated from the rest Tabs. Click and hold the left mouse button on the Work View Tab's header and then drag a desired Tab out. When a Work View Tab is separated from the rest of your Work View Tabs, again click and hold the left mouse button on the Work View Tab's header to display a cross-shaped Navigator icon. While holding the mouse button, bring the selected Work View Tab closer to the Navigator icon and release the mouse button at your desired position (top, left, right or bottom arrow). This time, the selected Tab will be moved to the desired position.

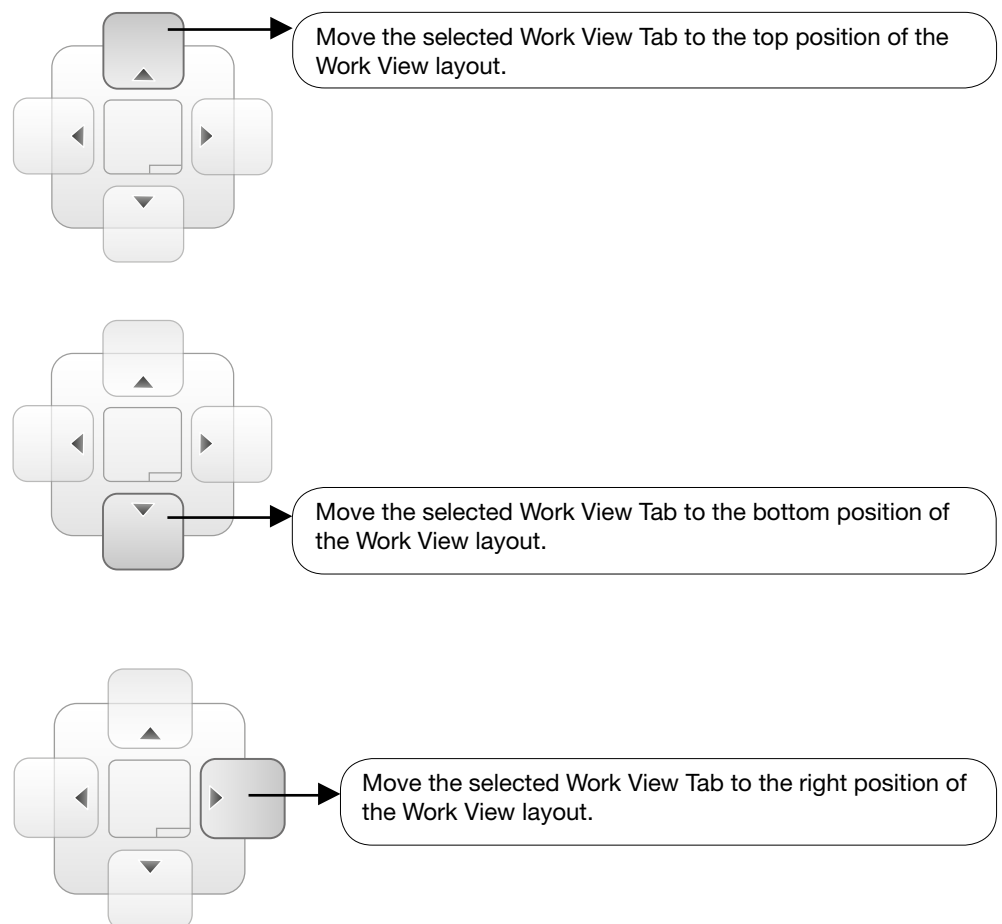

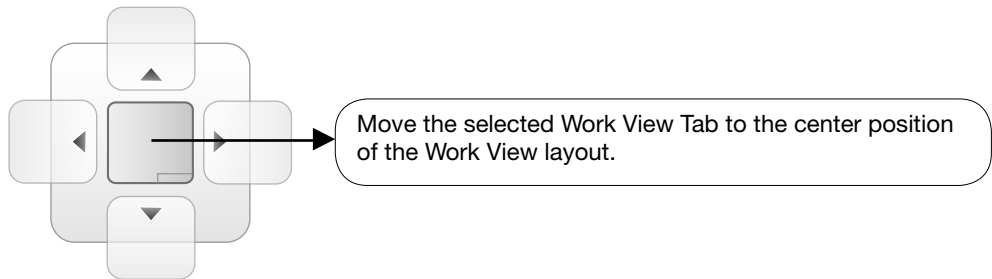
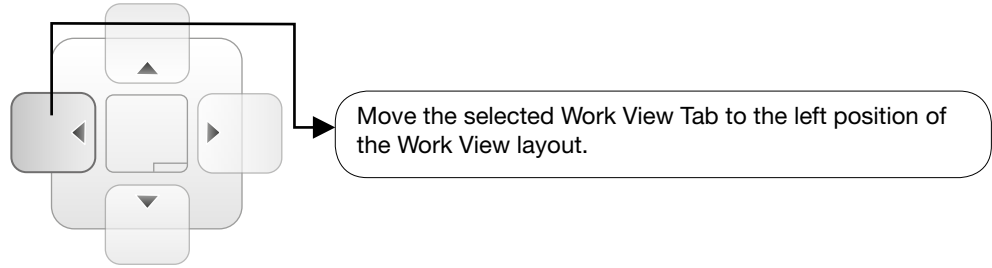

- Horizontal or Vertical Tab Group

The Work View Tabs can be also aligned horizontally or vertically. Without dragging them out, right-click the mouse button on a desired Tab header and select 'New Horizontal Tab Group' or 'New Vertical Tab Group' option. Selecting 'New Horizontal Tab Group' will separate a selected Tab from the rest of other Tabs then arrange it in a horizontal format. Likewise, selecting 'New Vertical Tab Group' will separate a selected Tab from the rest of other Tabs then arrange it in a vertical format.

- Closing the Work View Tab

To close the Work View Tab, right-click the mouse button on a desired Tab header and select 'Close' option in the drop down list. To close all Work View Tabs except the selected Tab, select 'Close All But This' option in the drop down list.

- Zoom Tool

Using the Zoom tool, you can easily select the magnification you want by using Zoom In and Zoom Out bar, and Fit in Work View button.



Fit Work View Button: fits the current view to the Work View window size. The button toggles between the fit view and the previous view.

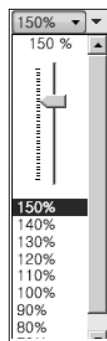

Zoom In and Zoom Out Bar: zooms in and out to expand and reduce the View to the desired size. (The zoom changes in 10% increments.)



View Switch Button: displays a list of the current views in a list. Choosing one of these views will display the selected view in the Work View window.



View Name Button: displays the current Work View name.



Close View Button: closes the current view.

REMOTE ACCESS (WEB MANAGEMENT & CONTROL)

Introduction

Main Page

Page Login
Top menus
Dash Board & Information

Antenna Settings

Ship setting
Antenna Position & Parameters
Tracking setting
Diagnostic

Firmware & Configuration

Antenna Firmware Upgrade
Antenna Log
Antenna Backup & Restore

Administration

Network Setting
Serial Setting [2]
SNMP Setting
User Management
E2S (Ethernet-to-Serial) Upgrade
E2S Save & Reboot
E2S Log

Introduction

With embedded Web M&C (Monitoring and Control) function, the s80HD WorldView™ can be monitored, controlled, and diagnosed remotely from anywhere, anytime through the TCP/IP protocol. This not only can save time but also save the cost generated from routine maintenance activities such as operating firmware upgrades, tracking parameters resets, and system diagnostic.

How to access Web M&C:

1. Connect an Ethernet Cable between your PC and the Management Ethernet Port.
2. Enter the ACU's IP address (192.168.2.1) into your web browser's address bar to login into the ACU's internal HTML page, if this system has not been changed from the ACU's factory default.

NOTE: Web M&C can be displayed in Internet Explorer 7 or later and is also compatible with Firefox and Chrome web browser.

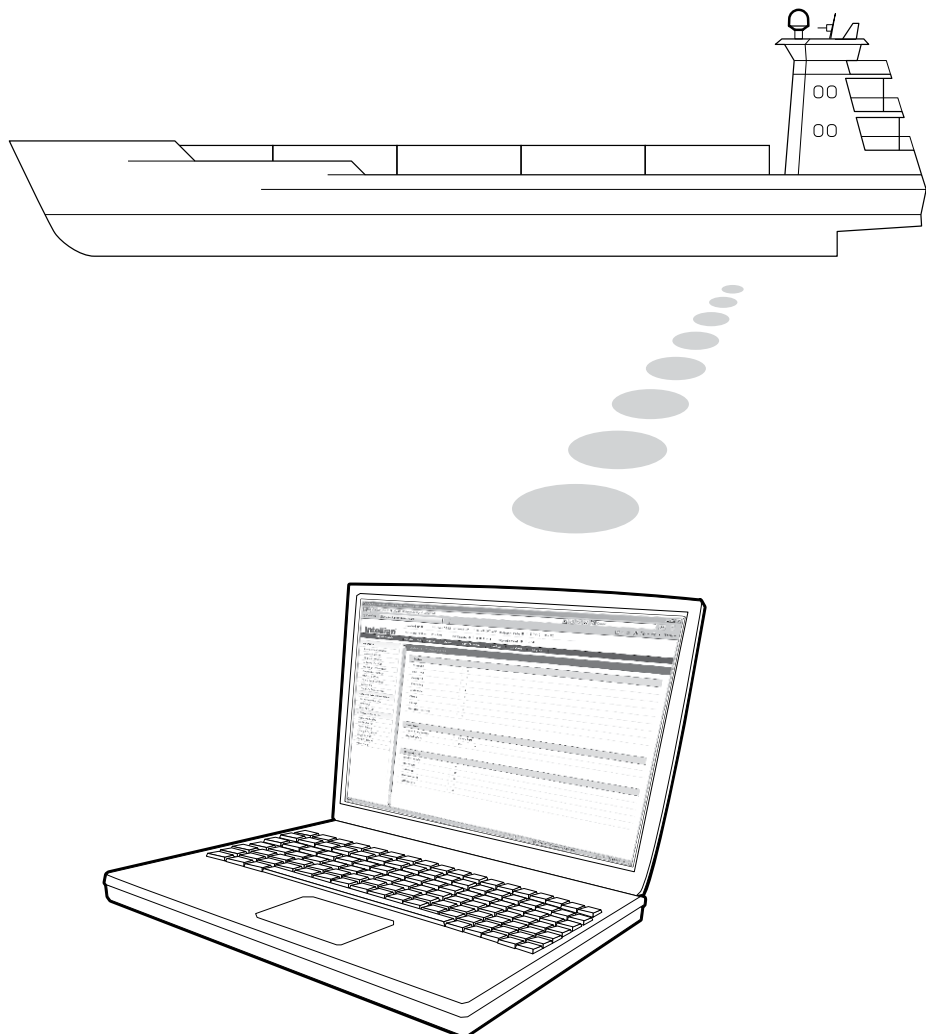

Main Page

Page Login

1. Choose either to Control & Monitor the ACU (Control & Monitoring) or Only Monitor the ACU (Monitoring Only).
2. Log into the ACU by typing in User Name and Password information. If this system has not been changed from the factory default:

- **User Name:** intellian
- **Password:** 12345678

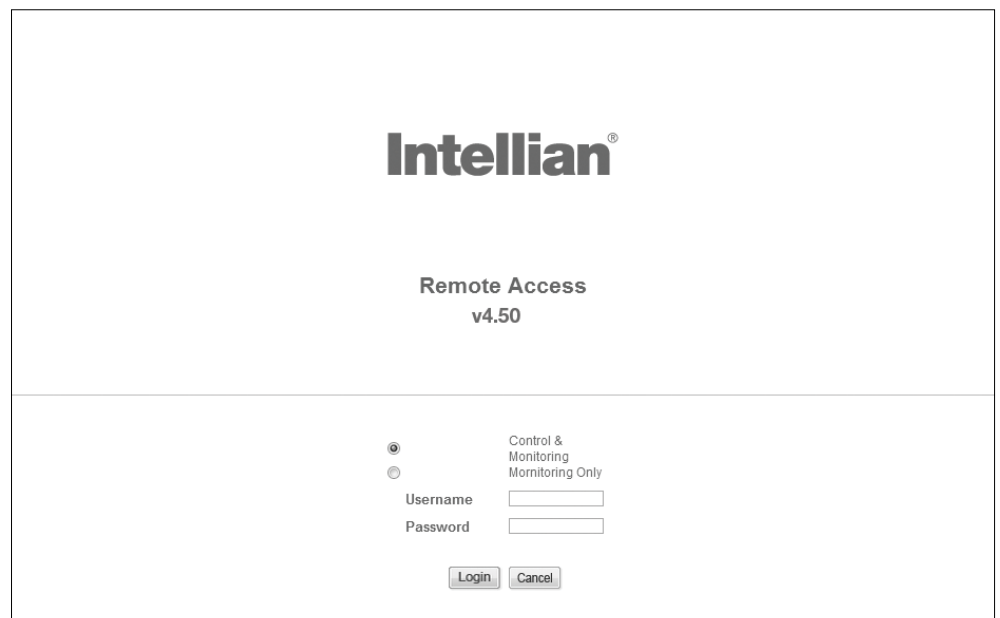

Intellian[®]

Remote Access
v4.50

Control & Monitoring
 Monitoring Only

Username

Password



WARNING: The Control & Monitoring Mode will be switched to the Monitoring Only Mode in the following cases;

- If PC Software (Aptus) is connected using TCP/IP Communication while Web M&C Control is in use.
- If Web M&C Control & Monitoring Mode is accessed while PC Software is running via TCP/IP Communication. In this case, the web page will display a pop-up message asking if you want to disconnect the PC Software network connection. If you select 'No', the Control & Monitoring Mode will be switched to the Monitoring Only Mode.

Top Menus

Once you log in, the following information and menus are displayed.



No.	Item	Description
①	Signal Level	Display current signal level.
②	Antenna status	<ul style="list-style-type: none"> - Setup: Displays whether or not the antenna is in SETUP mode. The indicator shows “Blue” in the SETUP mode. - Initial: Antenna or ACU is initialized. - Search: Antenna is searching a target satellite. - Track: Antenna is tracking the target satellite.
③	Restart	Restart the antenna system.
④	Setup	Enter SETUP mode.
⑤	Save Sat.	Save current satellite settings. Bow offset will be adjusted and saved automatically.
⑥	Ant. Info	Obtain current antenna information.
⑦	Account	Shortcut to User Management menu. Change login ID and Password.
⑧	Logout	Logout the ACU's internal HTML page.

Dash Board & Information

On the left side of the page, Dash Board and Information menus are displayed as below to provide quick monitoring of the antenna status and settings. Other menus are displayed only in the Control & Monitoring mode and their functions will be described in the next sections.

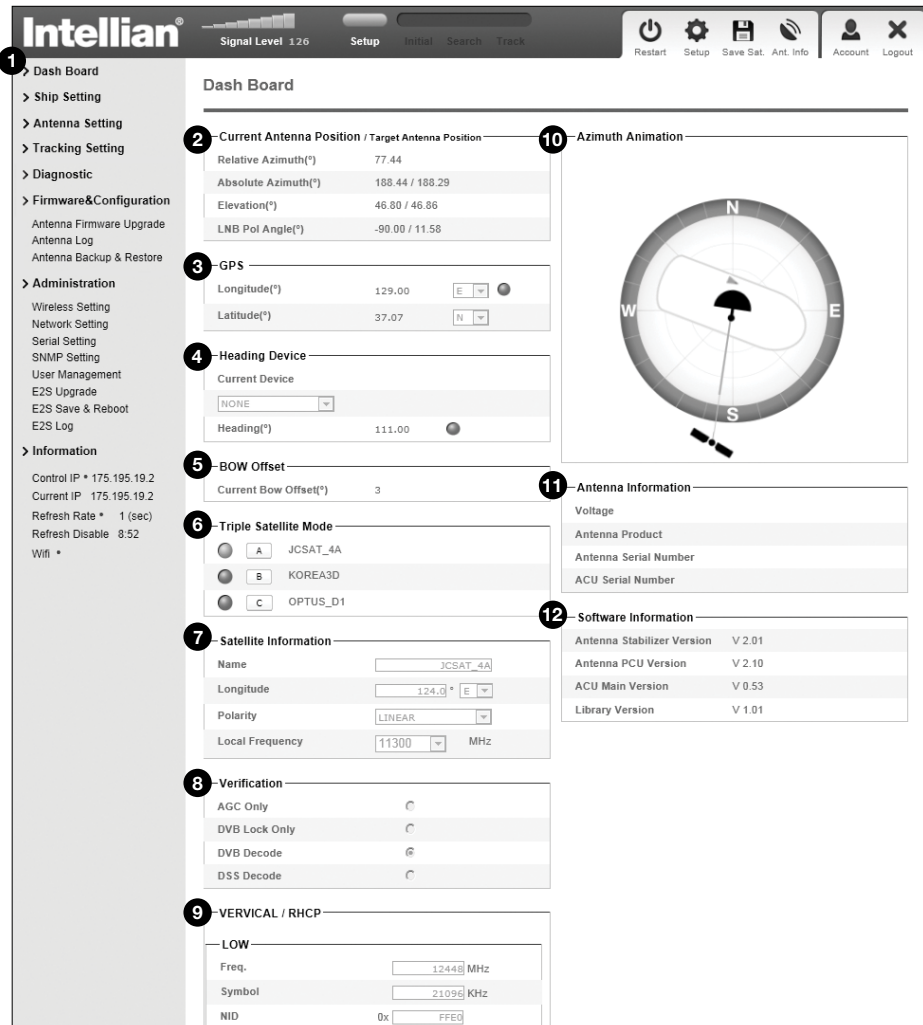

No.	Item	Description
①	Dash Board	Displays current antenna status to be quickly monitored.
②	Current Antenna Position / Target Antenna Position	Displays current antenna position. - Relative Azimuth: displays antenna relative AZ angle. - Absolute Azimuth: displays antenna absolute AZ angle. - Elevation: displays antenna elevation angle. - LNB Pol Angle: displays LNB pol angle.
③	GPS	Displays current GPS information. - Longitude (East / West) - Latitude (North / South)
④	Heading Device	Displays current Heading Device: NONE, NMEA, NMEA 2000, Ground test If the ship's gyro input is other than NMEA separate purchase of GYRO Converter is required. - Heading: displays ship's heading information.

⑤	BOW Offset	Displays current bow offset
⑥	Triple Satellite Mode	Mode: Select between Dual-Sat mode and Triple Sat mode.
⑦	Satellite Information	Displays the satellite name, longitude, polarity and LNB local frequency of the current satellite.
⑧	Verification	Displays current verification method for satellite tracking.
⑨	Tracking Information (Frequency band)	Displays current frequency band that consists of frequency, symbol and NID (Network ID) of a transponder in tracking the satellite.
⑩	Azimuth Animation	Shows a graphical representation of the current antenna position to identify whether or not the antenna is aligned properly to the target satellite or is in a blockage zone.
⑪	Antenna Information	Displays the product information
⑫	Software Information	Displays current Antenna and ACU firmware versions and Satellite Library version installed in the system. - Antenna Stabilizer Version - Antenna PCU Version - ACU Main Version - Library Version

Antenna Settings

Ship Setting

No.	Item	Description
①	Ship Setting	Set the ship information and find antenna angle.
②	GPS	Set GPS information. - Longitude (East/West) - Latitude (North/South)
③	Bow Offset	Set Bow Offset if needed.
④	Heading Device	Set ship's heading device (NONE, NMEA, NMEA2000, Ground Test) and ship's heading information
⑤	Antenna Angle	Find the current antenna angles and skew angle in relation to the longitude (orbit position) of the antenna's current GPS. Click 'Find Angles & Skew Antenna GPS' button.



WARNING

WARNING: Enter the SETUP mode for configuration. Tick the checkbox before modifying the settings. After configuration, click 'Set ...' button to submit the settings.

Antenna Position & Parameters

No.	Item	Description
①	Antenna Setting	Set current antenna position and Search and Tracking parameters. These parameters should only be changed by an authorized service technician. Improper setting of these parameters will render your system inoperable.
②	Current Antenna Position / Target Antenna Position	Display current antenna position. - Relative Azimuth: display antenna relative AZ angle. - Absolute Azimuth: display antenna absolute AZ angle. - Elevation: display antenna elevation angle. - LNB Pol Angle: display LNB pol angle. - Heading: display ship's heading information.
③	Manual Movement	Move antenna azimuth and elevation angles and LNB pol angle to find the desired satellite manually. LNB Pol Angel can be adjusted at any time either in SETUP Mode or Tracking Mode.
④	LNB Pol Sensor Calibration	Calibrate the LNB pol angle when the control board, potentiometer or LNB Assembly is replaced.

⑤	Elevation Adjust	Adjust the elevation to offset the angle difference between the mechanical elevation angle and actual elevation angle.
⑥	Idle Mode	Release the elevation and cross level motor brakes while the antenna is in SETUP mode. The antenna can be moved manually during the mode.
⑦	Reboot	Reboot the system.
⑧	Flag Setting	Set the flag settings. Select 'Use WRS Method' to use 'WRS(Wide Range Search) Detect Level'. Select 'Use Offset Difference' to enable the system to offset the signal difference between RHCP and LHCP.
⑨	Search & Tracking Parameter Setting	<ul style="list-style-type: none"> - Detect Level Threshold: display / set current detect level threshold to set the satellite signal detection level. - Tracking Level Threshold: display /set current tracking level threshold to set the satellite signal tracking level. - Wait Time: set the time-out for automatic initiation of a search after the signal level drops below the pre-defined threshold value. - Search Step: set increment step size - Search 2 Range: is reserved for future use - Search 1 Range: set Search 1 search range. The antenna is detecting the satellite signal which is above the current detect level threshold. The search range corresponds to Search Type 1. Once the signal is located, the antenna will enter to "Search 3 mode". - Search 3 Range: set Search 3 search range. The antenna is detecting the satellite signal which is above current tracking level threshold. The search range corresponds to Search Type 3. Once the signal is located, the antenna will enter "Tracking mode".
⑩	Tilt Sensor Bias	Adjust the two solid-state tilt sensors used to provide absolute cross-level tilt of the antenna and elevation feedback to eliminate long-term pointing drift (error). Tilt bias is required to be adjusted when the antenna control board or sensor box is replaced. Check to see whether or not the bubble is located at the center of the level vial.
⑪	Rate Sensor Adjust	Calibrate DC voltage output from the three rate sensors used to sense antenna motion in azimuth, elevation and cross-level axes. During the calibration process, the antenna should avoid any motion as it can affect the antenna's performance.

⑫ Parameter Setting

-
- Initial Sat Count: Set the threshold count for maintaining tracking.
 - WRS Detect Level: Set the WRS detection level.
 - Voltage Threshold: Set the voltage threshold. The voltage threshold is to distinguish the voltage between 13 V and 18V.
 - DiSEqC Threshold: Set the DiSEqC threshold. The DiSEqC threshold is to distinguish the 0KHz tone and 22 KHz tone.
 - Sat Verify Time: Set the threshold count for the satellite verification.
 - Tracking Stable Count: Set the threshold count for stabilizing the satellite before tracking.
 - Offset Diff AZ-EL: Set the offset difference between Azimuth and Elevation range.
 - Search Lock Count: Set the threshold count for locking on the satellite before tracking.
 - Offset Diff RH-LH: Set the offset difference between RHCP and LHCP signals.
-



WARNING: Tick the checkbox before modifying the settings. After configuration, click 'set...' button to submit the settings.

Tracking Setting

No.	Item	Description
①	Tracking Setting	Display or set current tracking satellite and tracking information.
②	Tracking Satellite	Select the tracking satellite.
③	Triple Satellite Mode	Register the selected satellite in Tracking Satellite for Sat A, Sat B or Sat C. To select between Dual-Sat mode and Triple-Sat mode, press the 'Dual Satellite Mode' button or 'Triple Satellite Mode' button on the bottom of the screen.
④	Satellite Information	Set the satellite name, longitude, polarization and local frequency of LNB to be used.
⑤	Verification	Set the verification type for satellite tracking (AGC Only, DVB Lock Only, DVB Decode, DSS Decode)
⑥	Tracking Information	Tracking information consists of frequency, symbol and NID (Network ID) of a transponder in tracking satellite. There are four groups of tracking information. "Vertical/RHCP" is applied when IRD supply 13V, and "Horizontal/LHCP" is applied when IRD supply 18V. "LOW" is applied when DiSEqC signal (0 kHz tone) is not detected from IRD. "HIGH" is applied when DiSEqC signal (22 kHz tone) is detected from IRD. Pol & Band Control: The "Pol" controls 13V (Vertical/RHCP band) or 18V (Horizontal/ LHCP band). The "Band" controls DiSEqC 0KHz tone (Low band) and 22KHz tone (High band) After modifying information, press 'Edit Satellite Information' button, then new information is updated in the antenna.

Diagnostic

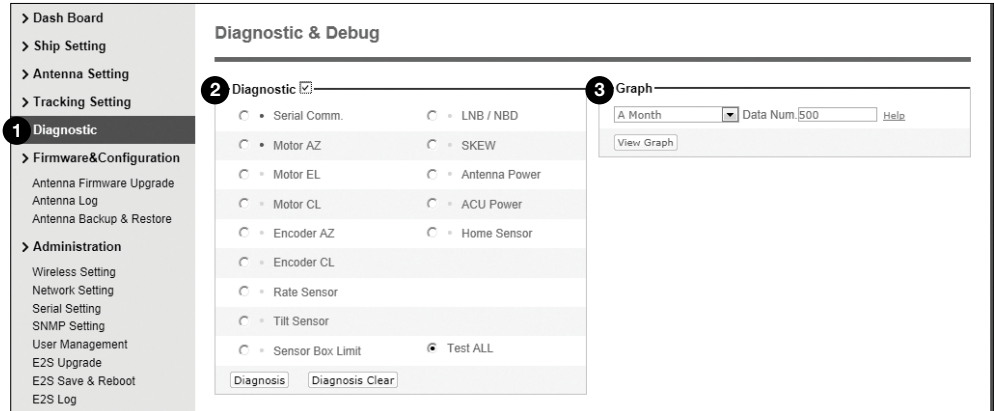

No.	Item	Description
①	Diagnostic	Execute antenna diagnostic test. Select to run a full diagnostic test or single diagnostic test. - Serial Comm.: test the data communication between the antenna and the ACU. - Motor AZ: test the azimuth motor. - Motor EL: test the elevation motor. - Motor CL: test the cross-level motor. - Encoder AZ: test the azimuth encoder. - Encoder CL: test the cross-level encoder. - Rate Sensor: test the gyro sensor. - Tilt Sensor: test the tilt sensor. - Sensor Box Limit: test the sensor box motor. - LNB/NBD: test the LNB. - SKEW: test the LNB pol motor. - Antenna Power: test the antenna power. - ACU Power: test the ACU power.
②	Diagnostic	<ul style="list-style-type: none"> - LNB/NBD: test the LNB. - SKEW: test the LNB pol motor. - Antenna Power: test the antenna power. - ACU Power: test the ACU power.
③	Graph	Select to view a graph of AZ Absolute, AZ Relative, EL and Heading data of the antenna. The status of Graph Service Pack (see E2S Upgrade) should be loaded to use this menu. - A Month: display all data within a month - A Week: display all data within a week - A Day: display all data in a day - Real-time: display data in real time. Press F5 button to refresh. - Data Num: set the maximum number of graph data set to be displayed. - View Graph: select to view the data graph.



WARNING: Tick the checkbox before modifying the settings. Click Diagnosis button to execute diagnostic test. To clear previous diagnosis result, click Diagnosis Clear button.

Firmware & Configuration

Antenna Firmware Upgrade

No.	Item	Description
①	Antenna Firmware Upgrade	Upgrade antenna and ACU firmware version.
②	New Antenna Firmware	Browse and select the firmware package file to upload and click Start Upload button.
③	Rollback Upgrade	Roll back antenna and ACU firmware to previous package version or latest package version.

Upgrade procedures:

1. Select the upgrade package file.
2. Click on “Start Upload” button to transfer the Firmware package file (“*.fwp”) to E2S (Ethernet to serial) module.
3. After the package file is transferred, it’ll show “upgrade from vx.xx Version to vx.xx Version”. Enable the check box to select the firmware file that you wish to upgrade. To select all firmware files, click Select All Firmwares.
4. Click on “Start Upgrade” button.

Firmware upgrade status page

The Firmware Package v120726 Upgrade Status	
Antenna POL	Upgrade From v---- To v---- Ready
Antenna STABILIZER	Upgrade From v0.96 To v0.95 Ready
Antenna PCU	Upgrade From v0.95 To v0.95 Ready
ACU MAIN	Upgrade From v0.95 To v0.95 Ready

[Back to main page](#)

5. It'll display information about the upgrade process status on full screen.

Upgrade process status page

The Firmware Package v120726 Upgrade Status	
Antenna POL	Upgrade From v---- To v---- Skip
Antenna STABILIZER	Upgrade From v0.96 To v0.95 Success
Antenna PCU	Upgrade From v0.95 To v0.95 20 %
ACU MAIN	Upgrade From v0.95 To v0.95 Ready

[Back to main page](#)

6. If the firmware is successfully upgraded, it'll display "The firmware update is completed."

7. Click on "Back to main page" to go out of the screen.

To verify the upgraded firmware version, go to Dash Board > Software Information.

Upgrade complete page

The Firmware Package v120726 Upgrade Complete

Antenna POL "-----" "Skip"
Antenna STABILIZER "0.95" "Success"
Antenna PCU "0.95" "Success"
ACU MAIN "0.95" "Success"

The firmware update is completed.
If you receive an fail message, please try again.
Please refer to the User Guide if you have trouble connecting to the antenna.

[Back to main page](#)

NOTE: To roll back to the previous firmware package version or latest package version, select Rollback Upgrade menu on the Antenna Firmware Upgrade page.

Antenna Log

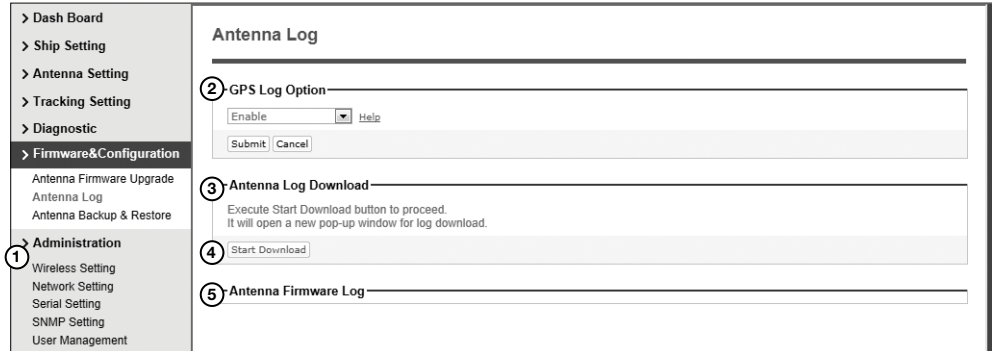

No.	Item	Description
①	Antenna Log	Displays antenna log data
②	GPS Log Option	Disable/Enable to save GPS information in the antenna log file.
③	Antenna Log Download	Download the log file. Select start download button to proceed.
④	Start Download	Download the antenna log information.
⑤	Antenna Firmware Log	Display log information of firmware upgrade.

Log Downloade procedures:

1. Select 'Start Download' button.
2. To run Java applications you must have Java Runtime Environment (JRE) version 6.0 and above installed in your PC/ laptop when you access the antenna log page for first time. Click "Run" button on the popup message "The application's digital signature cannot be verified. Do you want to run the application? " to install the Applet. Refer to Appendix for Java Installation Instructions if the system does not display the popup message.

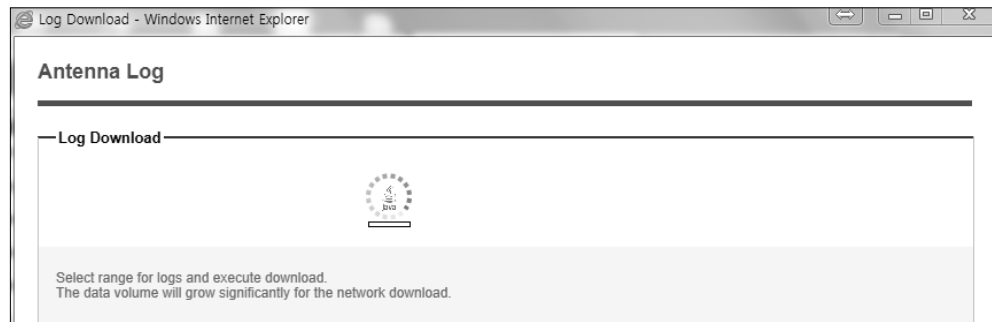

3. Select 'Browse' to browse the target directory of the antenna log file.
4. Select log period for file download.
 - Last 3 Months: download the antenna log information for the past three months.
 - Last 1 Month: download the antenna log information for the past one month.
 - Last 1 week: download the antenna log information for the past one week.
 - Last 1 Day: download the antenna log information for the past one day.
5. Select 'Download' to download the log file to the target directory according to the selected log period.

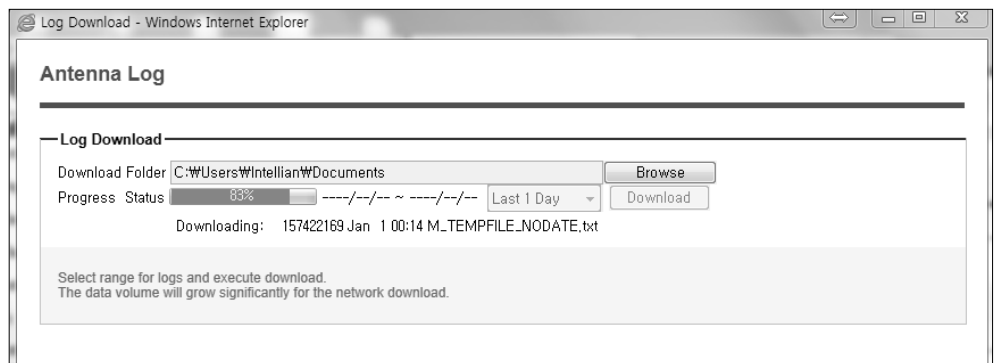

NOTE: In s80HD system, users can choose to Enable or Disable the GPS tracking function. Liability for information that is disclosed when GPS is enabled is solely the operators responsibility and it is up to the operator on whether or not to provide their GPS information to third parties. Any issues regarding safety and privacy when turning on the GPS function is solely up to the user. Intellian is not responsible for information that is disclosed when the GPS function is enabled.

Antenna Backup & Restore

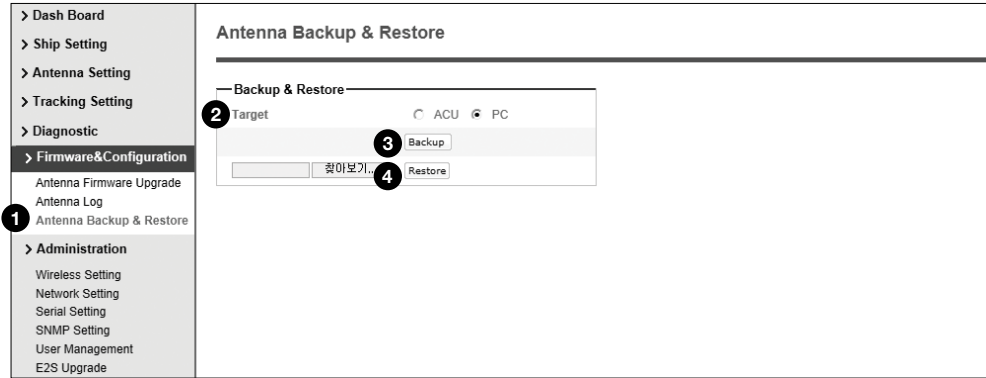

No.	Item	Description
①	Antenna Backup & Restore	Enter Backup & Restore page. (Setup mode is required)
②	Target	Backup antenna information to ACU/PC or restore antenna by using the saved information from ACU/PC.
③	Backup	Backup antenna information.
④	Restore	Restore antenna information.

Administration

WARNING: Ensure to enter the SETUP mode before starting configuration. After completing the modification of settings, enter Save & Reboot page and click on “Save & Reboot” button. Without doing so, the modified settings will be lost.

No.	Item	Description
①	Wireless Setting	Enter wireless setting page.
②	Wireless Network Configuration	<p>The E2S (Ethernet-to-Serial) supports WiFi Network. Turn on WiFi switch on the rear panel of the ACU to activate your WiFi networking.</p> <ul style="list-style-type: none"> - Wireless Network Mode: select an appropriate wireless network mode for your current WiFi network enviroment. - Wireless Network Name (SSID): The SSID is the network name shared among all devices in a wireless network. The SSID must be identical for all devices in the wireless network. It is case-sensitive and must not exceed 32 alphanumeric characters, which may be any keyboard character. Make sure this setting is the same for all dVICES in your wireless network. - Channel: select an appropriate channel from the list provided to correspond with your network settings. All devices in your wireless network must use the same channel in order to function correctly. Try to avoid conflicts with other wireless networks by choosing a channel where the upper and lower three channels are not in use. - Bitrate: select an appropriate bit rate for the wireless communication. If Bitrate is set to “Auto”, the optimized bitrate will be determined automatically. Please note that “802.11b Only Mode” supports 1, 2, 5.5, and 11Mbps, while “802.11g Only Mode” supports 6, 9, 12, 18, 24, 36, 48, and 54Mbps. In the mixed mode, all options are available.

-
- RTS Threshold: The RTS Threshold (RT) value which determines when the RTS/CTS handshaking mechanism should be used. RTS/CTS adds a handshake before each packet transmission to make sure that the channel is clear. This adds overhead, but increases performance in case of hidden nodes or a large number of active nodes. This parameter sets the size of the smallest packet for which the node sends RTS; a value equal to the maximum packet size disables the mechanism.
 - Fragment Threshold: allows to split an IP packet in a burst of smaller fragments transmitted on the medium. This adds overhead, but in a noisy environment this reduces the error penalty and allows packets to get through interference bursts. This parameter sets the maximum size which is always lower than the maximum packet size.
 - 802.11h: is a spectrum management standard designed to resolve wireless interference issues. If this option is set, E2S will auto switch the channels and control the transmission power to minimize the risk of interferences from other systems. This field only can be enabled in A band.
 - Wireless Roaming: the E2S supports roaming functionality. The access points for which you want to enable roaming must all have the same SSID.
 - Authentication Mode: the E2S supports an authentication mode which defines the procedure that the 802.11 device uses when it authenticates and associates with an access point or IBSS cell.
 - Encryption Type: The E2S supports different types of encryption settings for your network.
 - Key Index: select the key index to use WEP encryption.
 - Key: enter the key/ password which is used for connecting Antenna Control Unit (ACU) through WiFi.
 - Connection Type: select an obtaining IP address method for E2S's wireless network connection.
 - IP Address: the current Wireless IP address E2S is assigned to. If the connection type is set to DHCP, the current IP will be displayed but not be editable. Enter an appropriate IP address manually if the connection type is set to Static IP.
 - Subnet Mask: the current wireless subnet mask E2S is assigned to. If the connection type is DHCP, the current subnet mask will be displayed but not be editable. Enter an appropriate subnet mask manually if the connection type is set to Static IP.
 - Gateway: the current default gateway for wireless network E2S is assigned to. If the connection type is set to DHCP, the current default gateway will be displayed but not be editable. Enter an appropriate default gateway manually if the connection type is set to Static IP.
 - DNS: the current default wireless DNS address E2S is assigned to.
-

Network Setting

No.	Item	Description
①	Network Setting	Modify ACU's Internal IP address.
②	Ethernet Port Configuration	<p>Modify ACU's Internal IP address and press Submit button. Go to "Save & Reboot" page and press Save & Reboot button to validate the changes.</p> <ul style="list-style-type: none"> - IP Address: Factory default (Primary: 192.168.0.223) / (Secondary: 10.10.1.1) - Subnet Mask: Factory default (255.255.255.0) - Gateway (router IP): Factory default (192.168.0.254)
③	Management Port Configuration	<p>Modify Management Port's network configuration and press Submit button. Go to "Save & Reboot" page and press Save & Reboot button to validate the changes.</p> <ul style="list-style-type: none"> - Management Port: Set disable on Management Port connection if IP address conflicts across the network when Ethernet port and Management port are both in use. Factory default is set to Enable. - DHCP Server: Set whether or not to use DHCP Server. Enabling DHCP Server allows access to Web M&C page without configuration of network address on a PC. To use the DHCP service, the PC should be also set to use DHCP. - IP Address: Factory default (192.168.2.1) - Subnet Mask: Factory default (255.255.255.0) - Lease Start Address: Set Lease Start Address when DHCP Server is enabled. Factory default (192.168.2.2) - Lease End Address: Set Lease End Address when DHCP Server is enabled. Factory default (192.168.2.30) - Lease Time: Factory default is 180 min
④	Network Service Configuration	Select to enable or disable Telnet Service.
⑤	Browser Configuration	Modify browser refresh rate and refresh disable time. If the check box of Refresh Disable Time is enabled, then Refresh Disable Time function will be activated and system will keep monitoring all activities regardless of time-out.

Serial Settings [2]

No.	Item	Description
①	Serial Setting	Configure Serial port [2]
②	Serial Port [2]	<p>Port [2] is to communicate with the PC Control via Ethernet. Follow the below instruction to configure Serial port 2 and press Submit button. Go to “Save & Reboot” page and press Save & Reboot button to validate the changes.</p> <ul style="list-style-type: none"> • Operation mode: TCP Server • Local socket port: 4002 • Baud Rate : 57600 bps • Data Bit : 8 Bit • Stop Bit : 1 Bit • Parity : None • Flow Control : None • Port Login: Enable (Asks login information of other user who attempts to connect PC control software in the same network.) <p>The ACU control settings should be applied as same above.</p>
③	Port Login	Disabling the Port Login doesn't require ID and Password when accessing the web page.

SNMP Setting

No.	Item	Description
①	SNMP Setting	Configure SNMP settings.
②	V1/2 Attribution	Configure the SNMP v1/v2 attributes (Read-Only, Read- Write, Disable). The community name of SNMP v1 / v2 is "public".
③	V3 Attribution	Configure the SNMP v3 attributes (Read-Only, Read- Write).
④	V3 Username / Password	Set a v3 username & password of the SNMP agent.
⑤	TRAP IP / Port	Set the trap IP address and socket number of the SNMP trap server. Trap feature will be disabled if the trap IP is set to 0.0.0.0.
⑥	System Reset Notification	Enable or disable the system reset SNMP trap notification.
⑦	Port Connect Notification	Enable or disable the port connect SNMP trap notification.
⑧	Port Disconnect Notification	Enable or disable the port disconnect SNMP trap notification.

User Management

No.	Item	Description
①	User Management	Change login ID and Password to access the Web M&C. This setting can be also accessed by 'Account' icon on the top menu.
②	Change ID	Enter your current login ID (user name) and new login ID. Press Submit button to validate the changes that are made to the login ID.
③	Change Password	Enter your current login password and new login password. Press Submit button to validate the changes that are made to the login password.

E2S (Ethernet-to-Serial) Upgrade

The screenshot shows the 'E2S Upgrade' web interface. On the left is a navigation menu with categories: Dash Board, Ship Setting, Antenna Setting, Tracking Setting, Diagnostic, Administration (selected), Information, and Wifi. Under Administration, 'E2S Upgrade' is highlighted. The main content area is titled 'E2S Upgrade' and contains several sections:

- 1 E2S Upgrade:** A sidebar menu item.
- 2 New E2S Firmware:** A section with a file browser, current version information (Remote Access v3.70, Kernel v2.00, Bootloader v2.20), and a 'Start Upgrade' button.
- 3 E2S Service Pack:** A section with a file browser and a 'Start Upgrade' button.
- 4 New E2S Service Pack:** A section with a file browser and a 'Start Upgrade' button.
- 5 Service Pack Setting:** A table showing details for 'graph' and 'security' service packs, including version, description, and status (Unloaded).
- 6 Service Pack Status:** A section for viewing the status of the currently loaded service pack.

No.	Item	Description
①	E2S Upgrade	Upgrade the firmware of Ethernet-to-Serial module.
②	New E2S Firmware	Select a new E2S firmware file and click Start Upgrade button to upgrade the firmware of Ethernet-to-Serial module.
③	E2S Service Pack	Upgrade Adds-on by uploading Service Pack.
④	New E2S Service Pack	Select a new E2S Service Pack file and click Start Upgrade button to upgrade the Service Pack.
⑤	Service Pack Setting	Displays uploaded Service Pack information. Change the STATUS from Unload to Load to apply the new Service Pack.
⑥	Service Pack Status	Displays currently loaded Service Pack status.

E2S firmware upgrade procedures:

1. Click on “Browse” button to select the E2S firmware file (.bin) that you wish to upgrade.
2. Click on “Start Update” button to update the E2S firmware. Wait until the page is loaded.
3. It'll inform you that the firmware is being uploaded.

Firmware upload in progress

<ul style="list-style-type: none"> Wireless Setting Network Setting Serial Setting SNMP Setting User Management E2S Upgrade E2S Save & Reboot E2S Log <p>> Information</p> <ul style="list-style-type: none"> Control IP * 175.195.19.2 Current IP 175.195.19.2 Refresh Rate * 5 (sec) Refresh Disable 8:25 Wifi * 	<p>Please wait for file transfer...</p> <div style="border: 1px solid black; width: 100px; height: 15px; margin: 0 auto;"> <div style="background-color: gray; width: 20%; height: 100%;"></div> running </div>
---	---

4. Do not turn off the ACU power if the firmware upgrade page is displayed.

Firmware upgrade in progress

<ul style="list-style-type: none"> > Administration Wireless Setting Network Setting Serial Setting SNMP Setting User Management E2S Upgrade E2S Save & Reboot E2S Log <p>> Information</p> <ul style="list-style-type: none"> Control IP * 175.195.19.2 Current IP 175.195.19.2 Refresh Rate * 5 (sec) Refresh Disable 8:25 Wifi * 	<p>Please wait for updating system...</p> <div style="border: 1px solid black; width: 100px; height: 15px; margin: 0 auto;"> <div style="background-color: gray; width: 20%; height: 100%;"></div> running </div> <p style="font-size: 8px; margin-top: 5px;">DO NOT TURN OFF ACU.</p>
---	--

5. It'll take around 2 minutes to complete the firmware upgrade. Once the upgrade is completed, the system will reboot automatically.

<ul style="list-style-type: none"> > Dash Board > Ship Setting > Antenna Setting > Tracking Setting > Diagnostic > Administration Wireless Setting Network Setting Serial Setting SNMP Setting User Management E2S Upgrade E2S Save & Reboot E2S Log <p>> Information</p> <ul style="list-style-type: none"> Control IP * 175.195.19.2 Current IP 175.195.19.2 Refresh Rate * 1 (sec) Refresh Disable 8:55 Wifi 	<p>Save & Reboot</p> <hr style="border: 1px solid gray;"/> <p style="font-size: 8px; margin-top: 10px;">Now the device will reboot with new firmware. Please refer to the User Guide if you have trouble connecting to the device. This screen will be inaccessible in 10 seconds.</p>
---	---

6. The connection will be disconnected during the reboot. It'll take around 30 seconds to reboot the E2S module and get the connection back again. (Disconnection message may vary depending on the web browsers.)

E2S Service Pack upgrade procedures:

1. Click on "Browse" button to select the E2S Service Pack file (.bin) that you wish to upgrade.
2. Click on "Start Update" button to update the new E2S Service Pack. Wait until the page is loaded.
3. It'll inform you that the firmware is being uploaded displaying "Upgrade Complete" pop-up window. Click 'OK' to confirm.
4. Go to the Service Pack Setting menu and check that the Service Pack versions are correctly displayed.

Service Pack Setting						
NAME	VERSION	DESCRIPTION	FS VER MIN	OS VER MIN	SIZE	STATUS
security	1.00	SSL/TLS Added - HTTPs Support	2.20	2.00	1.76MB	Unload <input type="button" value="v"/>
MemFree :3MB DiskFree :20MB Load :0						
<input type="button" value="Submit & Reboot"/> <input type="button" value="Cancel"/>						
Service Pack Status						
NAME	VERSION	DESCRIPTION	FS VER MIN	OS VER MIN	SIZE	STATUS

5. Set the 'Unloaded' status to 'Load', then the message, 'All configuration changes made will be saved in the ACU and effective upon reboot' will be displayed. Click OK to proceed loading the Service Pack.

> Administration

- Wireless Setting
- Network Setting
- Serial Setting
- SNMP Setting
- User Management
- E2S Upgrade
- E2S Save & Reboot
- E2S Log

> Information

- Control IP * 175.195.19.2
- Current IP 175.195.19.2
- Refresh Rate * 5 (sec)
- Refresh Disable 8:30
- Wifi *

Please wait for rebooting system...

running

It takes around 10 seconds to complete.

If it is successful, the screen will be inaccessible.

In this case, please reconnect the web page

6. It'll take around 30 seconds to complete the reboot. Once the reboot is completed, the system will prompt you to login again. Click OK to proceed and login the page again.
7. Go to E2S Upgrade and check the Service Pack Status. It will display information of the loaded Service Pack with the status indicating 'LOADED'.

> Administration

- Wireless Setting
- Network Setting
- Serial Setting
- SNMP Setting
- User Management
- E2S Upgrade
- E2S Save & Reboot
- E2S Log

> Information

Control IP • 175.195.19.2
 Current IP 175.195.19.2
 Refresh Rate • 5 (sec)
 Refresh Disable 8:55
 Wifi •

E2S Service Pack

New E2S Service Pack

Browse and select the service pack file to upload. 찾아보기...

A different with firmware upgrade.
 Add-ons what unaffected whole system can be upgrade using service pack.
 Add-ons will be requested a version that file-system and os firmware more then current version.
 Service pack cannot be unloaded when DEDICATED on system
 Except that service pack can be LOAD , UNLOAD or DELETE.
 The update may take a few minutes to complete.
 The upload time may vary due to a variety of factors such as the speeds of your network.

Start Upgrade Cancel

Service Pack Setting

NAME	VERSION	DESCRIPTION	FS VER MIN	OS VER MIN	SIZE	STATUS
security	1.00	SSL/TLS Added - HTTPs Support	2.20	2.00	1.76MB	Load ▼

MemFree :3MB DiskFree :24MB Load :1

Submit & Reboot Cancel

Service Pack Status

NAME	VERSION	DESCRIPTION	FS VER MIN	OS VER MIN	SIZE	STATUS
security	1.00	SSL/TLS Added - HTTPs Support	2.20	2.00	1.76MB	LOADED

E2S Save & Reboot

The screenshot shows the 'E2S Save & Reboot' web interface. On the left is a sidebar menu with categories: Dash Board, Ship Setting, Antenna Setting, Tracking Setting, Diagnostic, Administration (selected), and Information. Under 'Administration', 'E2S Save & Reboot' is highlighted with a circled '1'. The main content area is titled 'E2S Save & Reboot' and contains two sections. The first section, 'Save & Reboot' (circled '2'), has a sub-header and a text box stating 'All configuration changes made will be saved in the ACU and effective upon reboot.' Below this is a 'Save & Reboot' button. The second section, 'Reboot without Saving' (circled '3'), has a sub-header and a text box stating 'All configuration changes made will be lost upon reboot.' Below this is a 'Reboot Only' button.

No.	Item	Description
①	E2S Save & Reboot	Save settings to the ACU and reboot or reboot the system without saving.
②	Save & Reboot	Save the modified settings and reboot the system. Click Save & Reboot button.
③	Reboot without Saving	Reboot the system without saving the modified settings. Click Reboot Only button.

E2S Log

- > Dash Board
- > Ship Setting
- > Antenna Setting
- > Tracking Setting
- > Diagnostic
- > Administration
- Wireless Setting
- Network Setting
- Serial Setting
- SNMP Setting
- User Management
- E2S Upgrade
- E2S Save & Reboot
- 1
- E2S Log
- > Information
- Control IP * 175.195.19.2
- Current IP 175.195.19.2
- Refresh Rate * 1 (sec)
- Refresh Disable 8:54
- Wifi

E2S Log

Access Log

Date/Time(UTC 00:00)	ID	IP
1970-01-01 02:32:31	intellian	175.195.19.2
1970-01-01 01:30:38	Tcp Access	175.209.202.159
1970-01-01 01:12:14	Tcp Access	175.209.202.159
1970-01-01 00:51:10	Tcp Access	175.209.202.159
1970-01-01 00:29:47	intellian	175.195.19.2
1970-01-01 00:27:06	intellian	175.195.19.2
1970-01-04 17:00:29	intellian	175.195.19.2
1970-01-04 16:59:43	intellian	175.195.19.2
1970-01-04 13:26:22	Tcp Access	175.209.202.159
1970-01-04 13:25:46	Tcp Access	175.209.202.159

No.	Item	Description
①	E2S Log	Displays user's log information (Date/Time, Login ID and IP)

Warranty

This product is warranted by Intellian Technologies Inc., to be free from defects in materials and workmanship for a period of 3 YEARS on parts and 1 YEAR on labor performed at Intellian Technologies, Inc. service center from the purchased date of the product.

Intellian Technologies, Inc. warranty does not apply to product that has been damaged and subjected to accident, abuse, mis-use, non-authorized modification, incorrect and/ or non-authorized service, or to a product on which the serial number has been altered, mutilated or removed.

It is required to present a copy of the purchase receipt issued by the re seller that indicates the date of purchase for after-sales service under the warranty period. In case of failure to present the purchase receipt, the warranty period will begin 30 days after the manufacturing production date of the product purchased.

Any product which is proven to be defective in materials or workmanship, Intellian Technologies, Inc. will (at its sole option) repair or replace during the warranty period in accordance with this warranty. All products returned to Intellian Technologies, Inc. under the warranty period must be accompanied by a return material authorization (RMA) number issued by the dealer/distributor from Intellian Technologies, Inc. and a copy of the purchase receipt as a proof of purchased date, prior to shipment. Alternatively, you may bring the product to an authorized Intellian Technologies, Inc. dealer/distributor for repair.

Appendix: Setup Bluetooth Connection

```
4 TRACKING 116.0E KOREA3HN AGC: 224# HL 4  
AZ: 201.4 (201.4) EL: 45.0 SK: -75.4 Fr
```

1. After setting up the s80HD and after authorizing the power supply, the antenna will confirm if it is operating normally.
2. In order to utilize the antenna's Bluetooth function, you have to connect a Bluetooth module (optional) to the D-sub connector on the antenna.

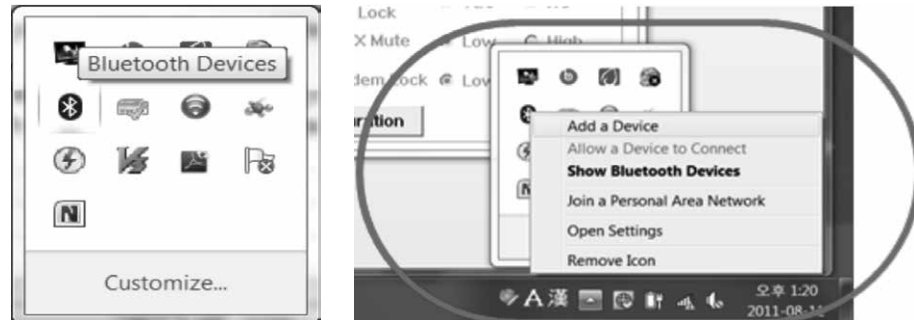

3. Prepare a notebook that has a Bluetooth device receiver or module included within it. While the Bluetooth device is getting ready to be used you can choose to add a bluetooth device if you right click on the Bluetooth icon.

※ Methods of setting up Bluetooth within your notebook can differ by the manufacturers software and Operating System being used within your notebook.

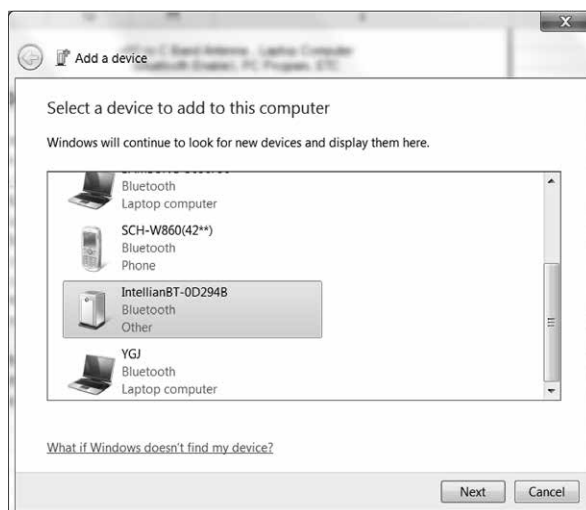

4. On the left is a window in order to run the setup wizard where you can add a Bluetooth device. Find the IntellianBT-0D294B Bluetooth Device (**0D294B may be a different number depending on each user**) and if you click next, then the wizard will search for a Bluetooth device. **The window for adding a bluetooth device may differ by the type of Operating System being used.**

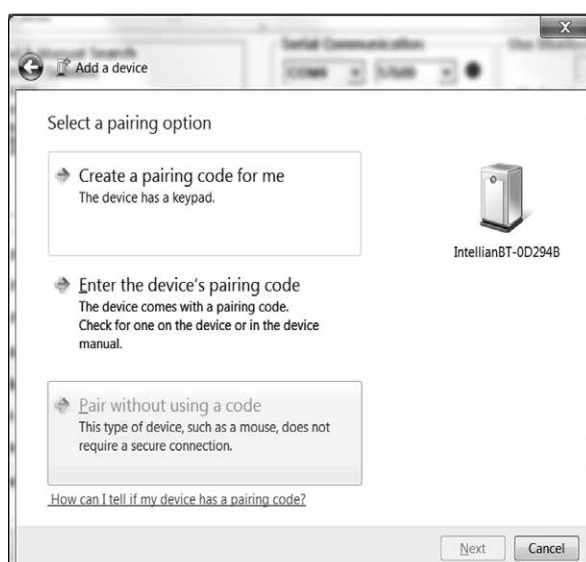

5. Pair the device without using a code. Select "Pair without using a code" and press Next.

NOTE: Some OS systems may not have an option to Pair the bluetooth device without using a code therefore, go to the next step to enter a Pairing Code.



6. The picture shown on the left is a Pairing Connection page. Enter the security code in order to go to the next page. Do this by entering "1234" within the Security Code box.

※ If the OS or the Bluetooth program has Skip button available, press the Skip button to go to the next page instead of entering a pairing code. The Pairing Window may differ by different OS systems used. The picture on the left is in Windows 7 format.

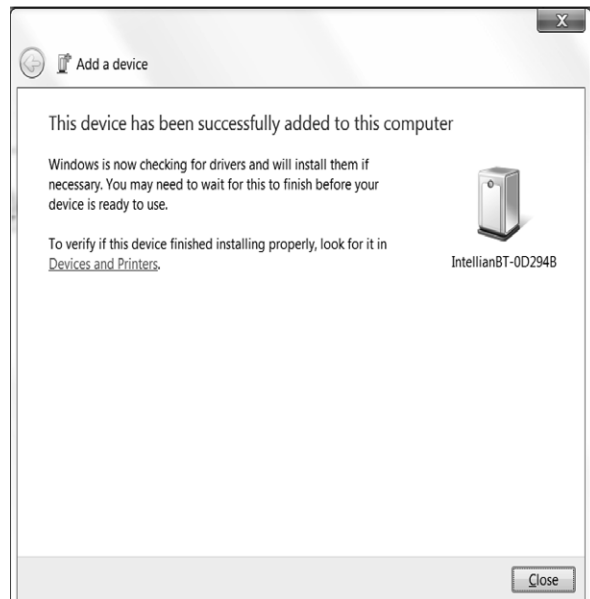

7. Pairing completed, the bluetooth device has been added to the computer. With Generic Serial Setup for OS systems that are different from Windows 7, go to a Generic Serial Service page (which applies to some OS Systems), select the Generic Serial Service and click Next.

Click Finish to complete Bluetooth setup tasks.

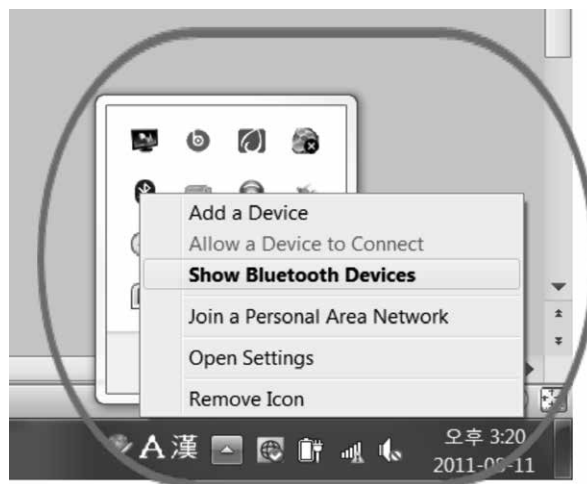

8. Go to your toolbar and right click on your WiFi logo. Click on "Show Bluetooth Devices" as shown in the picture on the left.



9. Right click on your bluetooth device called "IntellianBT-0D294B" (name may differ by user) and click on "Properties".



10. Go to the Hardware tab and check your COM Port Number.

NOTE: Remember the COM Port Number for step 12.

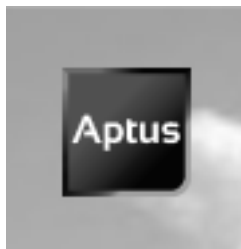

11. Run the Aptus Program.

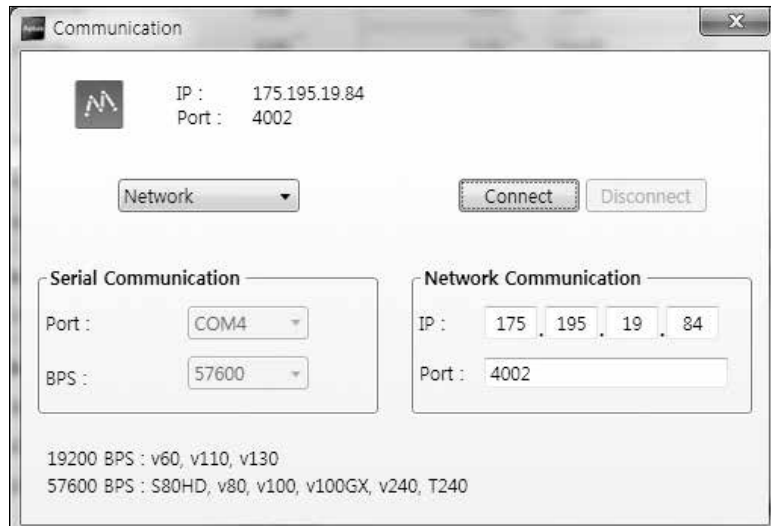

12. Click on Comm. icon to open the communication window. Assign the correct COM Port (step 10) and click the "Connect" button.

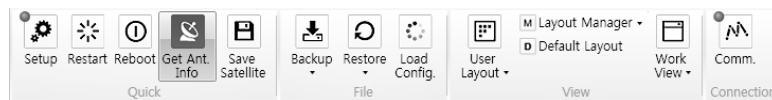

13. Press the "Get Ant. Info" button to confirm if the antenna's data within the Aptus Program is functioning normally.

End of Bluetooth Setup.

Technical Specification

General		
Approvals		
CE – conforms to	EU Directive 89/336/EEC	
FCC – verified to	CFR47:Part 15	
Dimensions		
Satellite antenna unit	120.5 cm x 113 cm (47.4" x 44.5")	
Antenna dish diameter	83cm (32.7")	
Antenna control unit	43.1cm x 38.1cm x 4.4cm (17" x 15" x 1.7")	
Weight		
Satellite antenna unit	86.2kg (190lbs)	
Antenna control unit	3.5kg (7.7 lbs)	
Antenna system performance (T2-878X)		
Antenna Type (T2-878X)	Cassegrain type	
Size	83cm (32.7")	
Polarization	Ku-band : Linear/Circular Switchable Ka-band: Circular	
Frequency	Ku-band : 10.7 ~ 12.75 GHz Ka-band : 18.3 ~ 18.8 / 19.7 ~ 20.2GHz	
Minimum EIRP	Ku-band : 43 dBW Ka-band : 44 dBW	
Axis	Three Axis: Azimuth, Elevation, Cross-level. Auto Skew	
Positioning	3-axis Velocity Mode Servo Control: Azimuth, Elevation, and Cross-Level	
Tracking Rates	Roll/Pitch/Yaw	±25° roll, ±15° pitch, ±8° yaw @ 6sec period
	Turning	Up to 12°/sec, 5°/sec ²
Range of Motion	Azimuth	690°
	Elevation	-15° to 110°
	Cross Level	±32°
Stabilization Accuracy	0.2° max in presence of specified ship motions	
LNB	WorldView™ Trio LNB (Ka and programmable World-View LNB)	
LO Frequency	Ku-band: 9.75/10.6 GHz (Universal mode), 10.5, 10.6, 10.678, 10.7, 10.75, 10.8, 11.0, 11.05, 11.2, 11.25 and 11.3 GHz (Single mode) Ka-band : 18.05 GHz	

Antenna Control Unit (BP-T8XX)		
Size	43.1cm x 38.1cm x 4.4cm (17" x 15" x 1.7")	
Weight	3.5kg (7.7 lbs)	
Display	2 Line 40 Character Graphic VFD Module	
User Control Key	20 touch key	
Gyrocompass Interface	NMEA 2000 / NMEA 0183	
GPS Interface	NMEA In / NMEA Out	
PC Interface	RS232C (57600bps 8, N, 1) / USB	
Remote Access	TCP / IP, Wi-Fi (Range: ~120 meters)	
Ethernet Port	2 x RJ45 (Front 1, Rear 1)	
RF Interface	Antenna Interface	F - Type
	STB Interface	F - Type
Power Requirement	100 ~ 240 V AC, 50~60Hz, 2A	

Intellian®

APAC

Headquarters

Intellian Technologies, Inc.
348-5 Chungho-Ri, Jinwi-Myeon
Pyeongtaek-Si, Gyeonggi-Do 451-862 Korea
T +82 31 379 1000 F +82 31 377 6185

Tech Support: SupportAPAC@intelliantech.com

Seoul Office

Intellian Technologies, Inc.
2F Dongik Building, 98 Nonhyun-Dong
Gangnam-Gu, Seoul 135-010 Korea
T +82 2 511 2244 F +82 2 511 2235

Americas

Irvine Office

Intellian Technologies USA, Inc.
9004 Research Drive
Irvine, CA 92618 USA
T 949 727 4498 F 949 271 4183

Tech Support: SupportAMERICAS@intelliantech.com

EMEA

Rotterdam Office

Intellian B.V.
Bristolstraat 1, 3047AB
Rotterdam, The Netherlands
T +31 1 0820 8655 F +31 1 0820 8656

Tech Support: SupportEMEA@intelliantech.com

UK Office

Intellian Ltd.
Epsilon House, Enterprise Road, Southampton Science Park,
Southampton, Hampshire SO16 7NS, United Kingdom
T +44 2380 019 021 F +44 2380 767 092

Maritime Technical Center

Busan Office

Intellian Technologies, Inc.
#906 Ace High Tech 21, 1470 Woo-Dong
Haeundae-Gu, Busan 612-020 Korea
T +82 51 746 9695 F +82 51 746 9440

info@intelliantech.com

www.intelliantech.com