

# Ku-band 25W BUC

## MODEL No. NJT5123 series

### < Features >

- \* **High Efficiency Output Power**
  - P1dB: +44 dBm min. over temperature
- \* **AC Power Operation**
  - Input Voltage: 110 / 220 VAC
- \* **Monitor and Control**
  - Analog Interface
  - Digital Interface
- \* **RoHS Compliance**



### < Line-Up >

Model No.	RF Frequency	Local Frequency	IF Frequency	Output Power @ P1dB	IF Connector	Power Supply	Port for Voltage Input	M&C Interface
NJT5123N	14.0 to 14.5 GHz	13.05 GHz	950 to 1,450 MHz	25W Linear (+44 dBm min.)	N-type	110 / 220 VAC	MS Connector	Analog
NJT5123ND								Analog/Digital

### < Specifications >

Item	Specifications	
Output Interface	Waveguide, WR75 (with Groove)	
Input Interface	N-type, female (50 ohm)	
Output Power @ 1 dB G.C.P.	+44 dBm min. over temperature	
Linear Gain	70 dB nom.	
IM3	-24 dBc typ. @ total power = +44 dBm - 3 dB -30 dBc max. @ total power = +44 dBm - 6 dB	
Requirement for External Reference	[Frequency]	10 MHz (sine-wave)
	[Input Power]	-5 to +5 dBm @ Input port
	[Phase Noise]	-125 dBc/Hz max. @ 100 Hz
		-135 dBc/Hz max. @ 1 kHz -140 dBc/Hz max. @ 10 kHz
L.O. Phase Noise	-60 dBc/Hz max. @ 100 Hz	
	-70 dBc/Hz max. @ 1 kHz	
	-80 dBc/Hz max. @ 10 kHz	
	-90 dBc/Hz max. @ 100 kHz	
Receive Band Noise Density	-119 dBm/Hz max. @10.95 to 12.75 GHz (without Receive band Rejection Filter)	
Input V.S.W.R.	2.0 : 1 max.	
Output V.S.W.R.	1.3 : 1 max.	
Power Requirement	110 / 220 VAC( 90 to 132 / 180 to 264 VAC, 47 to 63 Hz)	
Power Consumption	330 W max.	
Mute	Shut off the HPA in case of L.O. unlocked or no 10 MHz reference signal.	
Monitor and Control	Analog Interface [Model No.: NJT5123N/23ND]	
	Digital Interface [Model No.: NJT5123ND]	
Accessories	Receive band Rejection Filter, Bracket	
Temperature Range (ambient)	-40 to +55 C (operating), -40 to +75 C (storage)	
Dimension & Housing ( without Interface Connectors )	276 mm (L) x 246 mm (W) x 221 mm (H) [10.9" (L) x 9.7" (W) x 8.5" (H)]	
Weight	12 kg [25 lbs]	



## ■ Ku-band 25W BUC

### MODEL No. NJT5123 series

#### < Monitor and Control >

Item	Specifications	
Interface	Model No. NJT5123N: Analog Interface Model No. NJT5123ND: Analog Interface and Digital Interface	
Analog Interface	Function:	Power Detector, Temperature Monitor, Summary Alarm, Lock Monitor, Mute Input
Digital Interface	Interface:	RS-232 or RS-485(Optional) Including Monitor and Control Software
	Function:	RF Output Power Monitor, Temperature Monitor, LO Locked/Unlocked Monitor, LO Locked/Unlocked Monitor, Summary Alarm, HPA Mute Control

#### < Receive band Rejection Filter >

##### Specifications

Item	Specifications
Pass band	13.75 to 14.5 GHz
Insertion Loss within the Pass band	0.15 dB max.
Return Loss within the Pass band	20 dB min.
Rejection band	10.95 to 12.75 GHz
Rejection	50 dB min.
Input Interface	Waveguide, WR-75
Output Interface	Waveguide, WR-75 (with Groove)
Temperature Range (ambient)	-40 to +85 C (operating), -40 to +85 C (storage)
Dimension & Housing ( without Interface Connectors )	72.4 mm (L) x 38.1 mm (W) x 28.5 mm (H) [2.85" (L) x 1.50" (W) x 1.12" (H)]
Weight	110 g max. [0.24 lbs max.]

#### Outline Drawing

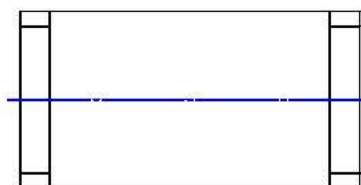
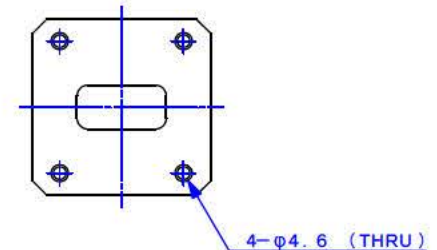
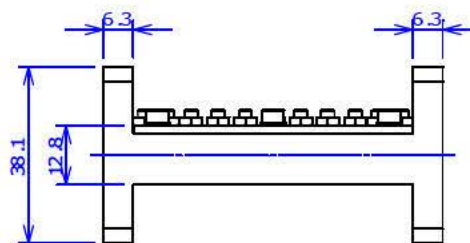
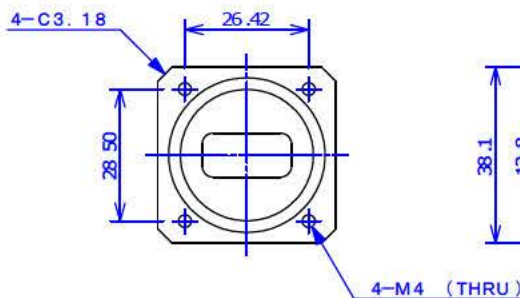
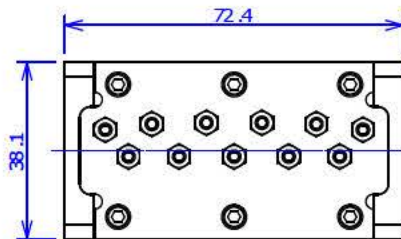
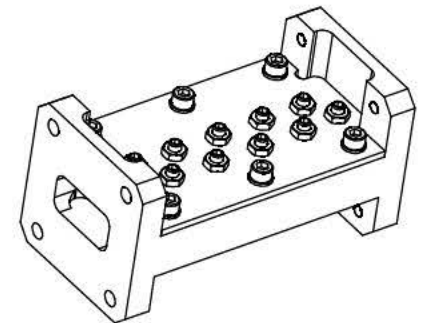

Unit: mm