



BUC

KA-BAND 25W

ATOMBKA025



NORSAT ATOM SERIES BUCS

Compared to equivalent products, ATOM series BUCs are:

- *Up to 20% smaller*
- *Up to 50% lighter*
- *Internal isolation to provide reflected power protection*

The Norsat ATOM series of block upconverters (BUC) are among the smallest, lightest, and most energy efficient transmitters available. The high efficiency of ATOM reduces power consumption significantly, delivering considerable operational cost savings over the lifetime of the device.

RF CONFIGURATIONS

Transmit Frequency

| | |
|-------------------|------------------|
| Military band | 30.0 to 31.0 GHz |
| Commercial band 1 | 29.0 to 30.0 GHz |

Input Frequency

| | |
|-------------------|-----------------|
| Military band | 1 to 2 GHz |
| Commercial band 1 | 950 to 1950 MHz |

* Custom within range

OPTIONS

| | |
|--------------------------|---|
| Baseplate Cooling | Fanless operation supporting external cooling systems |
| Ethernet | Ethernet M&C signalling |

HOW TO ORDER

ATOMBKA025-M

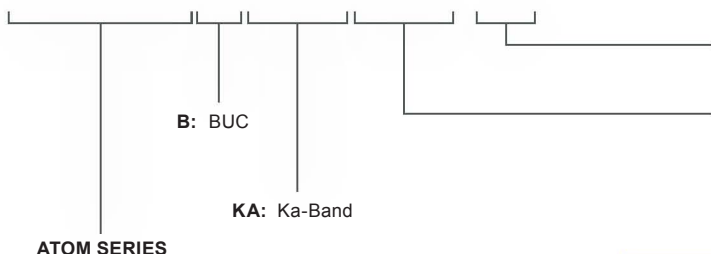

| | |
|-------------|---|
| Band | M - Military C - Commercial D - Dual Band |
| Psat | 025 - 25W 050 - 50W |



KA-BAND 25W BUC-ATOMBKA025

RF SPECIFICATIONS

| | |
|--|--|
| Output Power (Psat) | 44 dBm |
| Output Power (Plin) | > 41 dBm |
| Phase Noise | -72 dBc/Hz at 100 Hz -72 dBc/Hz at 1 KHz -82 dBc/Hz at 10 KHz -92 dBc/Hz at 100 kHz -102 dBc/Hz at 1 MHz |
| Noise Figure | 15 dB |
| Conversion Gain | 60 dB min |
| Gain Variation over 40MHz | +/- 0.5 dB |
| Gain Variation over 500 MHz | +/- 1.5 dB |
| Gain Variation over 1000 MHz | +/- 2.0 dB |
| Gain Variation over temperature | +/- 2 dB |
| Spurious in Band | -55 dBc |
| Spectral Regrowth @ Plin | -30 dBc |
| 3rd Order Intermod @ Plin | -25 dBc |

ENVIRONMENTAL & PHYSICAL

| | |
|------------------------------|--|
| Operating Temperature | -40 to +60°C (-40° to +140°F) |
| Storage Temperature | -54 to +105°C (-65° to +221°F) |
| Outline Dimensions | 7.10 x 3.64 x 6.83 in |
| Weight | 2.9 kg (6.3 lbs) |
| Enclosed accessories | Screws, gasket, M&C mating connector, power mating connector |

POWER

| | |
|--------------------------|---|
| Input Voltage | 20 – 56 VDC |
| Power Consumption | 200W @ Psat 150W @ Plin 25W muted |
| Power Connector | MIL-26482 Series 1 Shell size 12, 4 pins |

MONITOR & CONTROL

| | |
|--|--|
| Discrete Mute Control Voltage ranges | 0 - 0.8 V 3.0 - 5.0 V |
| Low | 0 - 0.8 V |
| High | 3.0 - 5.0 V |
| Fully programmable | |
| Mute enable can be high or low | |
| Mute default can be enabled or disabled | |
| M&C Connector | MIL-26482 Series 1 Shell size 12, 10 pins |
| M&C Signaling | RS-485, RS-232 or Ethernet |

INTERFACES

| | |
|----------------------------|----------|
| Input VSRW | 1.5 : 1 |
| Output VSRW | 1.5 : 1 |
| RF Input Connector | N (50 Ω) |
| RF Output Connector | WR-28 |

MECHANICAL DIAGRAM

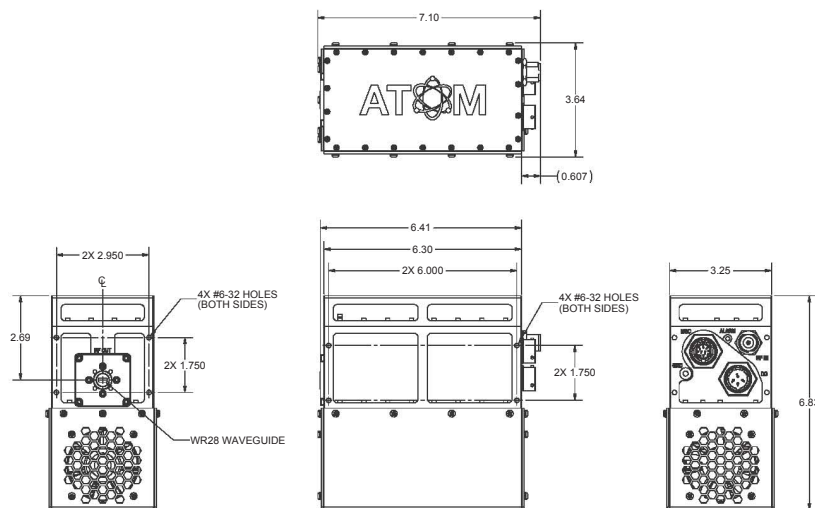

Norsat
International Inc.

North America
+1 800 644 4562

Asia Pacific
+1 604 821 2813

EMEA
+44 1522 730 800

South America
+1 604 821 2835

Online
www.norsat.com