



SSPA

KA-BAND 25W

ATOMSKA025



NORSAT ATOM SERIES SSPAS

Compared to equivalent products, ATOM series SSPAs are:

- *Up to 20% smaller*
- *Up to 50% lighter*
- *Internal isolation to provide reflected power protection*

The Norsat ATOM series of solid state power amplifiers (SSPA) are among the smallest, lightest, and most energy efficient transmitters available. The high efficiency of ATOM reduces power consumption significantly, delivering considerable operational cost savings over the lifetime of the device.

RF CONFIGURATIONS

Transmit Frequency

Military band	30.0 to 31.0 GHz
Commercial band 1	29.0 to 30.0 GHz
Custom – Specified within Bandwidth	

OPTIONS

Baseplate Cooling	Fanless operation supporting external cooling systems
Ethernet	Ethernet, M&C signaling

HOW TO ORDER

ATOMSKA025-M

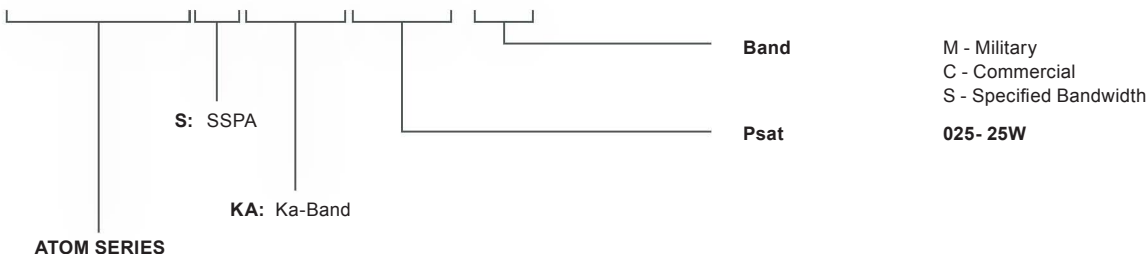

Buy Now!



KA-BAND 25W SSPA-ATOMSKA025

RF SPECIFICATIONS

Output Power (Psat)	44 dBm
Output Power (P1in)	> 41 dBm
Phase Noise	-66 dBc/Hz at 100 Hz -76 dBc/Hz at 1 KHz -86 dBc/Hz at 10 KHz -96 dBc/Hz at 100 kHz -106 dBc/Hz at 1 MHz
Noise Figure	15 dB
Conversion Gain	50 dB typ.
Gain Variation over 40MHz	+/- 0.5 dB
Gain Variation over 500 MHz	+/- 1.5 dB
Gain Variation over 1000 MHz	+/- 2.0 dB
Gain Variation over temperature	+/- 2 dB
Spurious in Band	-55 dBc
Spectral Regrowth @ P1in	-30 dBc
3rd Order Intermod @ P1in	-25 dBc

ENVIRONMENTAL & PHYSICAL

Operating Temperature	-40 to +60°C (-40° to +140°F)
Storage Temperature	-54 to +105°C (-65° to +221°F)
Outline Dimensions	7.10 x 3.64 x 6.83"
Weight	2.9 kg (6.3 lbs)
Enclosed Accessories	Screws, gasket, M&C mating connector, power mating connector

POWER

Input Voltage	20 – 56 VDC
Power Consumption	200W @ Psat 150W @ P1in 25W muted
Power Connector	MIL-26482 Series 1 Shell size 12, 4 pins

MONITOR & CONTROL

Discrete Mute Control Voltage ranges	
Low	0 - 0.8 V
High	3.0 - 5.0 V
Fully programmable	
Mute enable can be high or low	
Mute default can be enabled or disabled	
M&C Connector	MIL-26482 Series 1 Shell size 12, 10 pins
M&C Signaling	RS-485, RS-232 or Ethernet

INTERFACES

Input VSRW	1.5 : 1
Output VSRW	1.9 : 1
RF Input Connector	2.92 mm
RF Output Connector	WR-28

MECHANICAL DIAGRAM

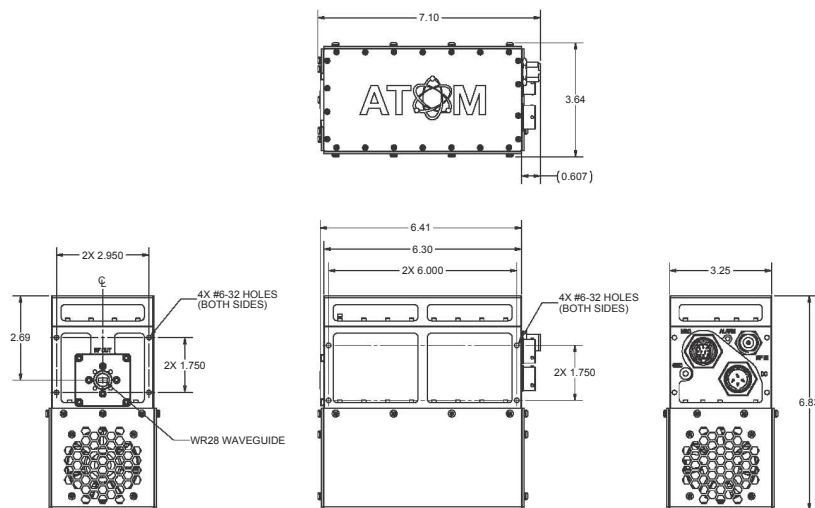

Norsat
International Inc.

North America
+1 800 644 4562

Asia Pacific
+1 604 821 2813

EMEA
+44 1522 730 800

South America
+1 604 821 2835

Online
www.norsat.com