



600W C-Band SSPA Chassis

Teledyne Paradise Datacom's Indoor, Rack Mount (R) series SSPAs represent the latest in High Power Microwave Amplifier Technology. The 4RU SSPA chassis achieves the highest power density in the industry along with enhanced maintainability.

Local, front panel, control is available with a user friendly interface. Five fault condition LEDs on left side of the front panel reflect some of the SSPA major faults states, plus a summary fault indicator. The SSPA online LED turns green when the amplifier is in Online mode (1:1 Mode) or serves as an AC power indicator in standalone mode. Local/Remote and Mute/Unmute LEDs show the current control mode and mute state of the amplifier.

A full compliment of serial and parallel (contact closure) control is also available from the rear panel. Teledyne Paradise Datacom's Windows™-based Universal M&C software allows monitor and control of the SSPA from a remote computer.

A state of the art thermal platform provides efficient cooling for the amplifier module and power supplies. This ensures the highest possible MTBFs for microwave power amplifiers.

Along with high reliability comes the ultimate in amplifier maintainability. Amplifier modules and power supplies are easily accessed making this one of the easiest amplifier assemblies to maintain in the field.

## FEATURES

- Extremely High Power Density:  
S Band to 600W ;  
C Band to 600W ;  
X Band to 500W ;  
Ku Band to 250W
- Removable Fan Trays
- Removable M&C Card
- RF Output Sample Port (-40 dB)
- RF Gain Adjustment  
55 dB - 75 dB
- Ethernet Port
- Universal, Power Factor Corrected Power Supply
- Built-in 1:1 Redundancy Control

## OPTIONS

- N+1 Redundant Power Supply
- Extended Frequency Bands
- L-Band Input operation
- ZBUC™ converter
- Reflected Power Monitor
- Phase Combined Systems
- Input Sample Port
- Exhaust Duct Adapters
- Redundant and Phase Combined System Solutions

## SPECIFICATIONS

- Chassis:  
19.0 X 7.0 X 28.0 in  
483 X 178 X 711 mm  
75 lbs. / 34 kg;  
100 lbs. / 45 kg  
for units > 250W
- Gray powder coat finish
- Operating temperature:  
0 to +50 °C

**Buy Now!**



### S-Band SSPA Power Levels

PARAMETER	NOTES	LIMITS	UNITS
Frequency Range	Band A Band B	2.020 to 2.120 2.200 to 2.300	GHz GHz
Output Power @: Saturation/ $P_{1dB}$ (Typical/Guaranteed minimum)	<p>Band A</p> HPAS2050ARXXXXX (2.020 - 2.090 GHz) HPAS2100ARXXXXX (2.095 - 2.120 GHz) HPAS2200ARXXXXX (2.020 - 2.090 GHz) HPAS2200ARXXXXX (2.095 - 2.120 GHz) HPAS2300ARXXXXX (2.020 - 2.090 GHz) HPAS2300ARXXXXX (2.095 - 2.120 GHz) HPAS2400ARXXXXX (2.020 - 2.090 GHz) HPAS2400ARXXXXX (2.095 - 2.120 GHz) HPAS2500ARXXXXX (2.020 - 2.090 GHz) HPAS2500ARXXXXX (2.095 - 2.120 GHz) HPAS2600ARXXXXX (2.020 - 2.090 GHz) HPAS2600ARXXXXX (2.095 - 2.120 GHz)	$P_{sat}/P_{1dB}$ 47.5 / 47.0 (56/50) 50.5 / 50.0 (112/100) 53.5 / 53.0 (223/200) 53.0 / 52.5 (200/178) 55.0 / 54.5 (316/280) 54.4 / 54.0 (280/250) 56.5 / 56.0 (447/400) 56.0 / 55.5 (400/355) 57.2 / 57.0 (525/500) 56.7 / 56.5 (468/447) 58.0 / 57.5 (631/560) 57.5 / 57.0 (560/500)	dBm (W) dBm (W) dBm (W) dBm (W) dBm (W) dBm (W) dBm (W) dBm (W) dBm (W) dBm (W) dBm (W) dBm (W) dBm (W)
	<p>Band B</p> HPAS2050BRXXXXX (2.200 - 2.300 GHz) HPAS2100BRXXXXX (2.200 - 2.300 GHz) HPAS2200BRXXXXX (2.200 - 2.300 GHz) HPAS2300BRXXXXX (2.200 - 2.300 GHz) HPAS2400BRXXXXX (2.200 - 2.300 GHz) HPAS2500BRXXXXX (2.200 - 2.300 GHz) HPAS2600BRXXXXX (2.200 - 2.300 GHz)	47.5 / 47.0 (56/50) 50.5 / 50.0 (112/100) 53.5 / 53.0 (223/200) 55.0 / 54.5 (316/280) 56.5 / 56.0 (447/400) 57.2 / 57.0 (525/500) 58.0 / 57.5 (631/560)	dBm (W) dBm (W) dBm (W) dBm (W) dBm (W) dBm (W) dBm (W)
Power Requirements	<p>power factor corrected 47 to 63 Hz</p> HPAS2050A/BRXXXXX (90 to 265 VAC) HPAS2100A/BRXXXXX (90 to 265 VAC) HPAS2200A/BRXXXXX (180 to 265 VAC) HPAS2300A/BRXXXXX (180 to 265 VAC) HPAS2400A/BRXXXXX (180 to 265 VAC) HPAS2500A/BRXXXXX (180 to 265 VAC) HPAS2600A/BRXXXXX (180 to 265 VAC)	250 500 1000 1600 1800 3500 3800	W W W W W W W

### Receive Band Noise and Filter Option

Receive Band Reject Filter Filter integrated into SSPA chassis through 400W Output; 500W and 600W SSPAs require an external filter.	Insertion Loss (Sub-Bands A & B) Rx Reject @ 2.200 GHz (Sub-Band A) Rx Reject @ 2.025 - 2.120 GHz (Sub-Band B)	- 0.5 - 60 - 60	dB dBc dBc
Receive Band Noise Power Density	Without optional filter With optional filter	-95 -155	dBw/4 KHz dBw/4 KHz



**Digisat International Inc.**  
 4195 W. New Haven Ave., Suite 15  
 Melbourne, FL 32904  
 USA  
 +1-321-676-5250  
 Email: sales@digisat.org  
 http://www.digisat.org

### C-Band SSPA Power Levels

PARAMETER	NOTES	LIMITS	UNITS
Frequency Range	(see options for extended band)	5.850 to 6.425	GHz
Output Power @: Saturation/ $P_{1dB}$ (Typical/Guaranteed minimum)	HPAC2050ARXXXXXX HPAC2075ARXXXXXX HPAC2100ARXXXXXX HPAC2140ARXXXXXX HPAC2200ARXXXXXX HPAC2250ARXXXXXX HPAC2300ARXXXXXX HPAC2400ARXXXXXX HPAC2500ARXXXXXX HPAC2600ARXXXXXX	$P_{sat} / P_{1dB}$ 47.0/46.8 (50/48) 48.8/48.5 (76/70) 50.0/49.5 (100/89) 51.5/51.0 (141/126) 53.0/52.3 (200/170) 53.9/53.0 (250/200) 54.7/54.0 (300/251) 56.0/55.0 (400/316) 57.0/56.0 (500/400) 57.8/57.0 (600/500)	dBm (W) dBm (W) dBm (W) dBm (W) dBm (W) dBm (W) dBm (W) dBm (W) dBm (W) dBm (W)
Power Requirements Line Voltage Line Frequency Line Power	power factor corrected 47 to 63 Hz HPAC2050ARXXXXXX (90 to 265 VAC) HPAC2075ARXXXXXX (90 to 265 VAC) HPAC2100ARXXXXXX (90 to 265 VAC) HPAC2140ARXXXXXX (90 to 265 VAC) HPAC2200ARXXXXXX (180 to 265 VAC) HPAC2250ARXXXXXX (180 to 265 VAC) HPAC2300ARXXXXXX (180 to 265 VAC) HPAC2400ARXXXXXX (180 to 265 VAC) HPAC2500ARXXXXXX (180 to 265 VAC) HPAC2600ARXXXXXX (180 to 265 VAC)	AC input  400 450 650 850 1000 1300 1700 2400 2800 3700	  W W W W W W W W W W

### Frequency Options

Extended Frequency Bands 5.850 to 6.725 GHz 5.75 to 6.67 GHz	De-rate output power by 1.0dB linearly from 6.425 to 6.725 GHz De-rate output power by 1.0dB linearly from 6.425 to 6.67 GHz and by 0.5 dB from 5.85 to 5.75 GHz
--	---

### X-Band SSPA Power Levels

PARAMETER	NOTES	LIMITS	UNITS
Frequency Range	(see options for extended band)	7.90 to 8.40	GHz
Output Power @: Saturation/ $P_{1dB}$ (Typical/Guaranteed minimum)	HPAX2060ARXXXXX HPAX2075ARXXXXX HPAX2100ARXXXXX HPAX2140ARXXXXX HPAX2200ARXXXXX HPAX2250ARXXXXX HPAX2350ARXXXXX HPAX2500ARXXXXX	$P_{sat} / P_{1dB}$ 47.5/47.3 (60/54) 48.8/48.3 (76/68) 50.0/49.5 (100/89) 51.4/50.8 (140/120) 53.0/51.8 (200/170) 54.0/53.3 (250/214) 55.5/54.5 (354/282) 57.0/56.0 (500/400)	dBm (W) dBm (W) dBm (W) dBm (W) dBm (W) dBm (W) dBm (W) dBm (W)
Power Requirements Line Voltage Line Frequency Line Power	power factor corrected 47 to 63 Hz HPAX2060ARXXXXX (90 to 265 VAC) HPAX2075ARXXXXX (90 to 265 VAC) HPAX2100ARXXXXX (90 to 265 VAC) HPAX2140ARXXXXX (180 to 265 VAC) HPAX2200ARXXXXX (180 to 265 VAC) HPAX2250ARXXXXX (180 to 265 VAC) HPAX2350ARXXXXX (180 to 265 VAC) HPAX2500ARXXXXX (180 to 265 VAC)	AC input  650 700 750 1225 1370 2450 3000 3500	  W W W W W W W W

### Frequency Options

Extended Frequency Band 7.70 to 8.40 GHz 7.50 to 8.50 GHz	De-rate output power by 1.0dB linearly from 7.90 to 7.70 GHz
---	--

### Ku-Band SSPA Power Levels

PARAMETER	NOTES	LIMITS	UNITS
Frequency Range	(see options for extended band)	14.00 to 14.50	GHz
Output Power @ Saturation/ $P_{1dB}$ (Typical/Guaranteed minimum)	HPAK2025ARXXXXX HPAK2035ARXXXXX HPAK2040ARXXXXX HPAK2050ARXXXXX HPAK2070ARXXXXX HPAK2100ARXXXXX HPAK2125ARXXXXX HPAK2200ARXXXXX HPAK2250ARXXXXX	$P_{sat} / P_{1dB}$ 44.0/43.0 (25/20) 45.5/44.5 (35/28) 46.0/45.0 (40/31) 47.0/46.0 (50/40) 48.5/47.5 (70/56) 50.0/49.0 (100/80) 51.0/50.0 (125/100) 53.0/52.0 (200/158) 54.0/53.0 (250/200)	dBm (W) dBm (W) dBm (W) dBm (W) dBm (W) dBm (W) dBm (W) dBm (W) dBm (W)
Power Requirements Line Voltage Line Frequency Line Power	power factor corrected 47 to 63 Hz HPAK2025ARXXXXX (90 to 265 VAC) HPAK2035ARXXXXX (90 to 265 VAC) HPAK2040ARXXXXX (90 to 265 VAC) HPAK2050ARXXXXX (90 to 265 VAC) HPAK2070ARXXXXX (90 to 265 VAC) HPAK2100ARXXXXX (180 to 265 VAC) HPAK2125ARXXXXX (180 to 265 VAC) HPAK2200ARXXXXX (180 to 265 VAC) HPAK2250ARXXXXX (180 to 265 VAC)	AC input  320 350 500 500 550 1100 1200 2500 2800	VAC Hz W W W W W W W W

### Frequency Options

Extended Frequency Band 13.75 to 14.50 GHz	De-rate output power by 1.0dB linearly from 14.00 to 13.75 GHz
---	--

### Common Electrical Specifications

PARAMETER	NOTES	LIMITS	UNITS
Gain	minimum	75	dB
Gain Flatness	full band	±1.0	dB
	Extended C-Band units	±1.5	dB
Gain Slope	per 40 MHz (C, X, Ku)	±0.3	dB/40 MHz
	Per 10 MHz (S-band)	±0.2	dB/10 MHz
Gain Variation vs. Temperature	0°C to +50°C	±1.0	dB
Gain Adjustment	0.1 dB resolution	20	dB
Intermodulation Distortion	3dB back off relative to P <sub>1dB</sub>	-25	dBc
AM/PM Conversion	(@ rated P <sub>1dB</sub> )	3.5	°/dB
	(@P <sub>1dB</sub> -3dB)	1.0	°/dB
Spurious Harmonics	(@ rated P <sub>1dB</sub> )	-70	dBc
	(@ rated P <sub>1dB</sub> -3dB) (C-,X-,Ku-bands)	-50	dBc
	(@ rated P <sub>1dB</sub> -3dB) (S-Band)	-40	dBc
Input/Output VSWR	All units except Extended C-Band	1.30:1	
	Extended C-Band units	1.50:1	
Noise Figure	at maximum gain	12	dB
Group Delay	Linear	0.01	ns/MHz
	Parabolic	0.003	ns/MHz <sup>2</sup>
	Ripple	1.0	ns p-p
Noise Output	TX Band (S, C-, X- or Ku-Band)	-75	dBW/4 KHz
	RX Band (C- or Ku-Band)	-150	dBW/4 KHz
	RX Band (X-Band)	-100	dBW/4 KHz
	RX Band (S-Band; see page 2)		
Residual AM Noise	0 - 10 KHz	-45	dBc
	10 KHz - 500 KHz	-20 (1.25 + log F)	dBc
	500 KHz - 1 MHz	-80	dBc
Residual Phase Noise	Offset frequency from carrier		
	10 Hz	-90	dBc/Hz
	100 Hz	-100	dBc/Hz
	1 KHz	-110	dBc/Hz
	10 KHz	-120	dBc/Hz
	100 KHz	-125	dBc/Hz
	1 MHz	-130	dBc/Hz
Connectors	RF Input, Input & Output Sample	Type N	Female
	RF Output: HPAS2XXXXRXXXXX	Type N	Female
	RF Output: HPAC2XXXXRXXXXX	WR137 Waveguide	CPR137G Flange (PDR-70)
	RF Output: HPAX2XXXXRXXXXX	WR112 Waveguide	CPR112G Flange (PDR-84)
	RF Output: HPAK2XXXXRXXXXX	WR75 Waveguide	Grooved Flange (PBR-120)
	Line Power	(90-265) IEC 6100-3300	Plug
		(180-265) IEC 4798-9000	Plug

### Mechanical

Size	width X height X depth	19.0 X 7.0 X 28.0 483 X 178 X 711	inches mm
Weight	≤ 250W Chassis	75 (34)	lbs.(kg)
	> 250W Chassis	100 (45)	lbs.(kg)
Finish		powder coat	Gray

### Environmental Specifications

Operating Temperature	Ambient	0 to +50	°C
Relative Humidity	non-condensing	95	%
Cooling System	Integrated	Forced air	

Specifications are subject to change.

## L-Band Operation

Teledyne Paradise Datacom offers C-, X-, and Ku-Band amplifiers with an integrated L-Band Block Up Converter. The L-Band units utilize Teledyne Paradise Datacom's proprietary ZBUC™ technology. The addition of a ZBUC converter to a 4RU Rack Mountable SSPA typically increases the gain by 2-4 dB. The advantages of ZBUC™ technology include:

- ZBUC converters can detect and switch to an externally supplied reference.
- Optional internal high stability (10MHz) reference.
- ZBUC converters can lock to an externally supplied reference of 5, 10, 20, 25, or 50 MHz without modification.
- ZBUC converters can accept a wide range of external reference power (-10 to +5 dBm)
- ZBUC converters can accept FSK monitor and control signal via the IFL for complete amplifier remote control.

## Available Frequency Plans

Band	Frequency Band	IF Input	LO Frequency	RF Output	Gain Change
C	Standard C-Band	950 - 1525 MHz	4.900 GHz	5.850 - 6.425 GHz	0-4 dB
C	Extended C-Band	950 - 1825 MHz	4.900 GHz	5.850 - 6.725 GHz	0-4 dB
C	Palapa Band	950 - 1250 MHz	5.475 GHz	6.425 - 6.725 GHz	0-4 dB
C	Insat Band	950 - 1250 MHz	5.775 GHz	6.725 - 7.025 GHz	0-4 dB
C	Extended C-Band 2	950 - 1675 MHz	4.800 GHz	5.750 - 6.475 GHz	0-4 dB
X	Standard X-Band	950 - 1450 MHz	6.950 GHz	7.900 - 8.400 GHz	0-2 dB
Ku	Standard Ku-Band	950 - 1450 MHz	13.050 GHz	14.00 - 14.50 GHz	0-2 dB
Ku	Extended Ku-Band	950 - 1700 MHz	12.800 GHz	13.75 - 14.50 GHz	0-2 dB

## Electrical Specifications for 4RU RM SSPA with ZBUC converter

PARAMETER	NOTES	LIMITS				UNITS
Gain	Nominal setting	75				dB
Gain Flatness	full band (C-,X-,Ku-bands)	±2.0				dB
Gain Slope	per 40 MHz (C-,X-,Ku-bands)	±0.5				dB/40 MHz
Gain Adjusted Range		20				dB
Gain Stability	Typical C-Band Adj. Range	60 - 80				dB
	Typical Ku-Band Adj. Range 0 to +50 °C	57 - 77				dB
Phase Noise	Offset frequency from carrier	<u>Absolute max.</u>	<u>C-band (typ.)</u>	<u>X-band (typ.)</u>	<u>Ku-band (typ.)</u>	
	10 Hz	-30	-60	-60	-50	dBc/Hz
	100 Hz	-60	-80	-75	-65	dBc/Hz
	1 KHz	-70	-80	-75	-72	dBc/Hz
	10 KHz	-80	-85	-100	-90	dBc/Hz
	100 KHz	-90	-120	-110	-110	dBc/Hz
	1 MHz	-90	-125	-122	-120	dBc/Hz
Spurious	In-Band Signal Related (C-/Ku-Band) (Extended C-Band)	-50				dBc
	Close to Carrier Spurious (≤ 20 MHz)	-40				dBc
	Local Oscillator	-50				dBc
		-30				dBm
Noise Figure	At 75 dB gain setting	20				dB
Input VSWR	L-Band	1.5 : 1				
Internal Reference Option	Reference accuracy @ 25 °C	±1 • 10 <sup>-7</sup>				
	Reference Stability over Temperature (-40 to +90 °C)	±1 • 10 <sup>-8</sup>				



# 4RU Rack Mountable Solid State Power Amplifiers

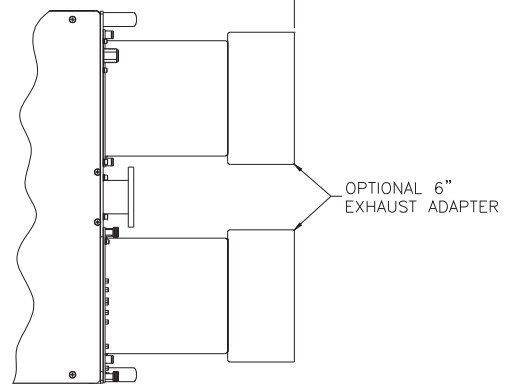
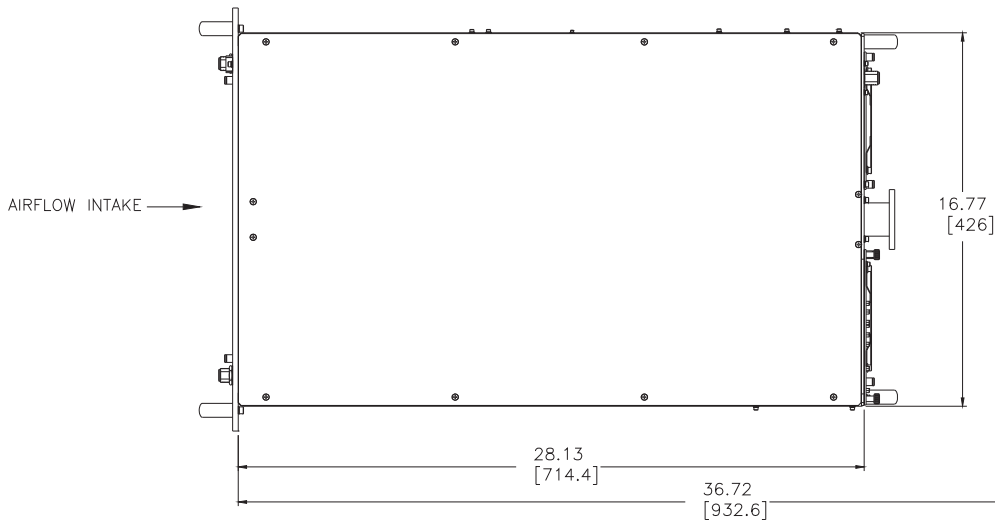
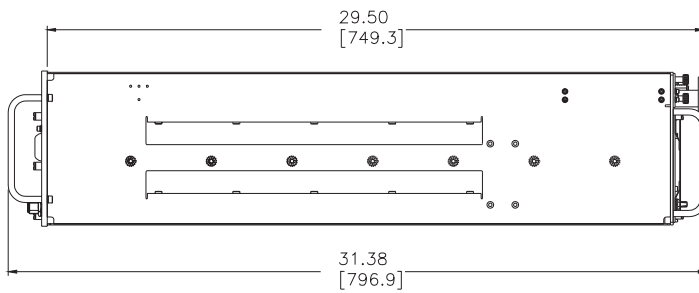
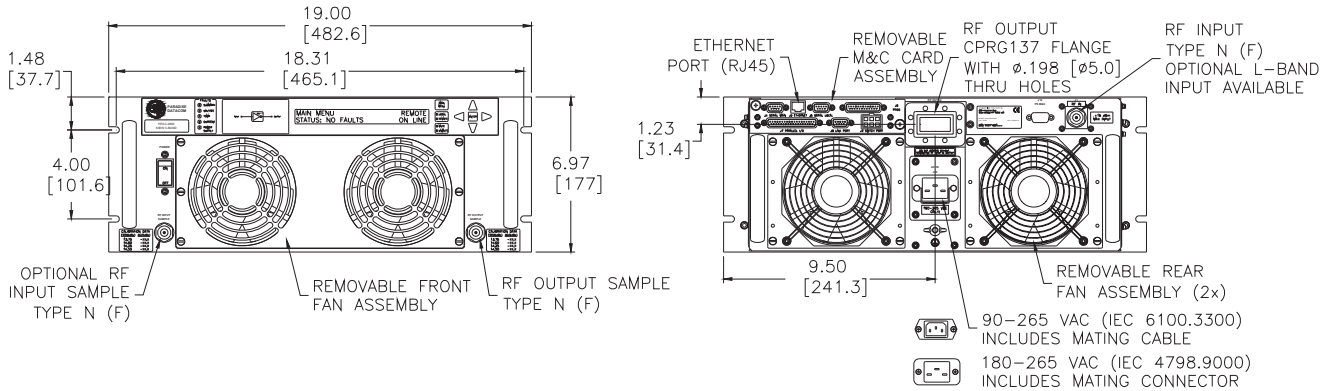

**Outline Drawing, 4RU SSPA  
 with Integral Power Supply**



## Redundant Power Supply Option

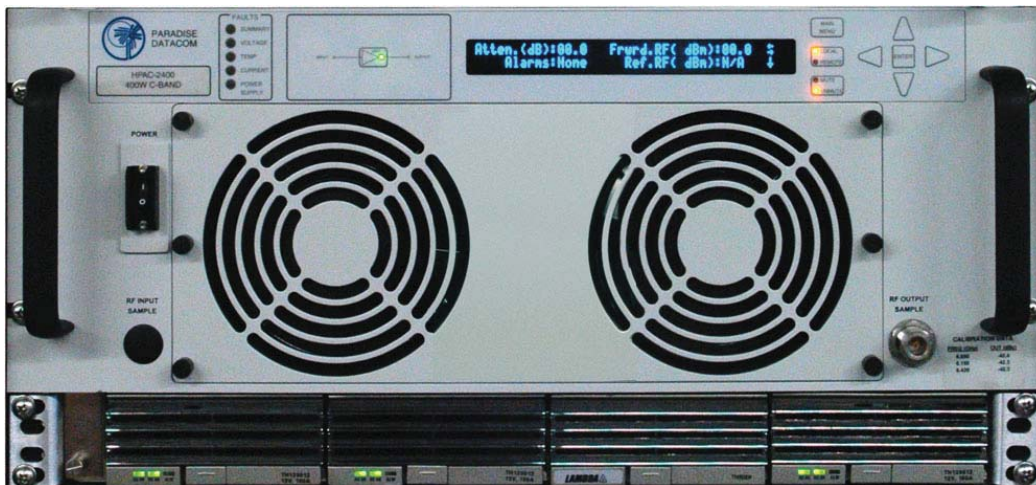

The combination of a separate +12 VDC output, fully redundant power supply is an excellent means of obtaining the ultimate system reliability.

The power supply is an N+1 redundant configuration meaning that there is one more power supply module available than is required to operate the SSPA. A failure of one power supply module will *not* take the amplifier off-the-air.

In addition the power supply modules are removable from the front panel while in operation. There is never a need to remove the power supply chassis from the equipment rack.

Weighing only 9 lbs. (4 kg) and occupying only 1 rack unit of cabinet space, the redundant power supply chassis is an excellent companion to the SSPA chassis.

The power supply has a single phase, universal AC input ranging from 90-265 VAC, 47-63 Hz. It is power factor corrected to 0.99. Depending on the power requirements of the SSPA, the power supply is configured with two, three or four 1200W hot-swappable modules, each of which weighs 5 lbs. (2.3 kg).

# 4RU Rack Mountable Solid State Power Amplifiers

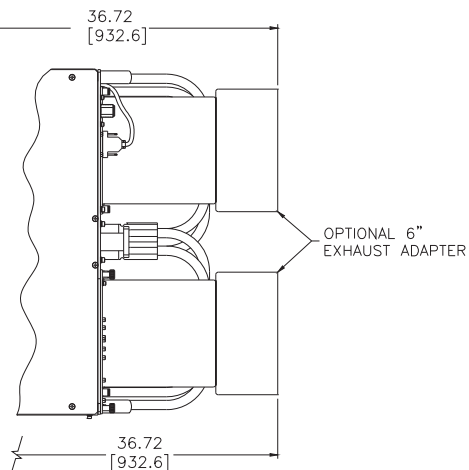
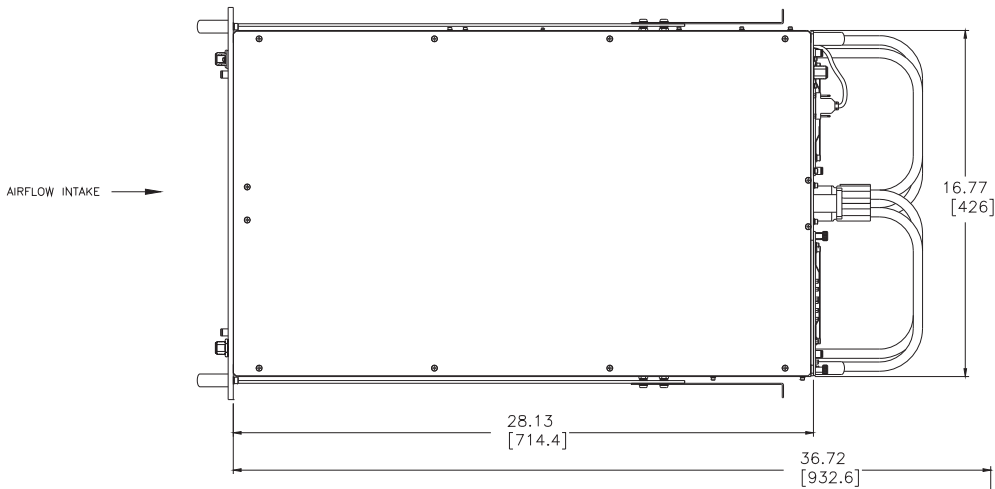
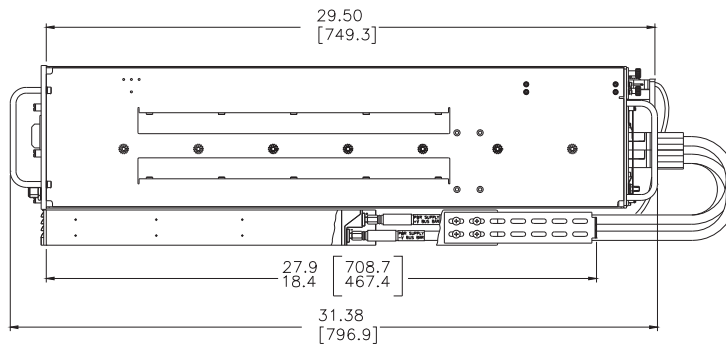
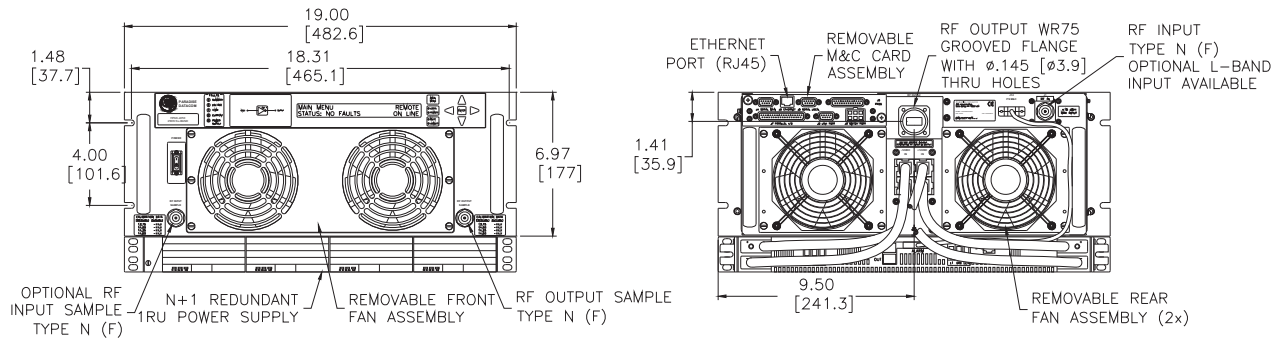

**Outline Drawing, 4RU SSPA  
 with N+1 Redundant Power Supply**

## Part Number Configuration

HPA  2  R  X

**Band**  
S - S-Band  
C - C-Band  
X - X-Band  
K - Ku-Band

**Power Level (in Watts)**  
S-Band  
050, 100, 200, 300, 400, 500 or 600  
C-Band  
050, 075, 100, 140, 200, 250, 300, 400, 500 or 600  
X-Band  
060, 075, 100, 140, 200, 250, 350 or 500  
Ku-Band  
025, 035, 040, 050, 070, 100, 125, 200 or 250

**Frequency Sub Band**  
S-Band  
A - 2.02 to 2.12 GHz  
B - 2.20 to 2.30 GHz  
C-Band  
A<sup>1</sup> - 5.850 to 6.425 GHz  
B<sup>1</sup> - 5.850 to 6.725 GHz  
C - 5.750 to 6.670 GHz  
E<sup>1</sup> - 6.425 to 6.725 GHz (Palapa)  
F<sup>1</sup> - 6.725 to 7.025 GHz (Insat)  
G<sup>1</sup> - 5.750 to 6.475 GHz  
V<sup>1,2</sup> - 5.850 to 6.725 GHz  
X-Band  
A<sup>1</sup> - 7.90 to 8.40 GHz  
B - 7.50 to 8.50 GHz  
C - 9.50 to 10.50 GHz  
D - 7.70 to 8.40 GHz  
Ku-Band  
A<sup>1</sup> - 14.00 to 14.50 GHz  
B<sup>1</sup> - 13.75 to 14.50 GHz  
  
<sup>1</sup> Available with optional BUC  
<sup>2</sup> With VSWR of 1.3:1

**Configuration Modifier**  
XXX = Standard  
CXX<sup>1</sup> = Input Sample & 110/220 VAC Operation  
KXX<sup>1</sup> = 110/220 VAC Operation  
SXX = Input Sample  
XVX = Reflected Power Monitor  
XXD = 48V Input  
XXE = Rear Panel Exhaust Adapters  
XXH<sup>2</sup> = 48V Input & Receive Band Reject Filter  
XXJ = 48V Input & Rear Panel Exhaust Adapters  
XXK<sup>2</sup> = Rear Panel Exhaust Adapters & Receive Band Reject Filter  
XXL = External 1RU N+1 Power Supply & Rear Panel Exhaust Adapters  
XXM<sup>2</sup> = External 1RU N+1 Power Supply & Receive Band Reject Filter  
XXP = External 1RU N+1 Power Supply  
XXR<sup>2</sup> = Receive Band Reject Filter  
<sup>1</sup> 100-125W Ku- & 200-300W C-Band only; Consult factory for S- & X-Bands.  
<sup>2</sup> S-Band only

**System Configuration**  
X = Standalone  
  
See the following datasheets for system options:

- Indoor Rack Mount Redundant SSPA Systems (203583)
- Indoor Rack Mount Phase Combined SSPA Systems (203584)

**Block Up Converter**  
B = BUC (Custom)  
M = Internal Reference ZBUC  
P = External Reference ZBUC  
X = N/A

**Package**  
R = Rack Mount (Standalone)

**Example** - A standalone 100W Extended Ku-Band Rack Mount SSPA with an optional 48 VDC input and no block up converter is part number: **HPAK2100BRXXXXD**.

Specifications listed in this document are subject to change without notice.  
X-Band products may be subject to ITAR restrictions and should not be exported from the U.S. without obtaining proper licensing from the appropriate government agencies.