



80W Ku-Band
 Mini Compact Outdoor SSPA

Description

The Teledyne Paradise Datacom Mini Compact Outdoor Solid State Power Amplifier (SSPA) is built for extreme environmental conditions and high reliability operation. Along with the robust construction exists the highest power density in the industry. This allows solid state technology to be used in applications that have long been reserved for TWTAs.

Gallium Nitride amplifiers offer considerably better performance than conventional GaAs solutions. GaN offers better efficiency than other conventional amplifier technologies and also exhibits exceptional gain and power over frequency.

Weighing less than 24.5 lbs. (11.2 kg), and 19.6 lbs. (8.9 kg) for the 80W Ku-Band units, and only slightly larger than a lunch box, this family of GaN SSPAs is available in the following output power levels:

C-Band: 200 W
X-Band: 200 W
Ku-Band: 80 W

FEATURES

- Compact size and weight
- CE Compliance Tested
- Integrated forced-air cooling system
- Adjustable RF Gain, 55 dB to 75 dB
- Extreme Environmental Testing
- RF Output Sample Port
- Maintenance Free Operation
- Universal, Power Factor Corrected Power Supply
- Built-in 1:1 Redundancy Control
- Remote M&C via Serial or Ethernet
- Integrated Output Isolator for load VSWR protection

OPTIONS

- Extended band operation
- Antenna Mounting Kit
- Remote Control Panel
- L-Band Input
- FSK monitor & control via IFL
- Phase Combined Systems
- Fiber Optic Interface
- Optional side-mount AC input for SNG installations

SPECIFICATIONS

- Compact Outdoor housing
 9.0 X 12.0 X 6.5 in
 229 X 305 X 165 mm
- White powder coat finish
- Operating temperature:
 -40 to +60 °C

BUY NOW

Specifications

	PARAMETER	NOTES	LIMITS	UNITS
C-BAND	Frequency Range	(see options for extended band)	5.850 to 6.425	GHz
	Output Power @: P_{sat} / Two-Tone P_{Linear} (Typical / Guaranteed minimum)	HPACC3200AC_XXXX	P_{sat} / P_{Linear} 53.0 / 50.0 (200 / 100)	dBm (W)
	Power Requirements Line Voltage Line Frequency Line Power	power factor corrected HPACC3200AC_XXXX @ P_{sat} HPACC3200AC_XXXX @ P_{Linear}	90 to 265 47 to 63 1100 880	VAC Hz W W
	Extended C-Band 5.85 to 6.725 GHz	De-rate output power by 1.0 dB linearly from 6.425 - 6.725 GHz		
X-BAND	Frequency Range		7.900 to 8.400	GHz
	Output Power @: P_{sat} / Two-Tone P_{Linear} (Typical / Guaranteed minimum)	HPAXX3200AC_XXXX	P_{sat} / P_{Linear} 53.0 / 50.0 (200 / 100)	dBm (W)
	Power Requirements Line Voltage Line Frequency Line Power	power factor corrected HPAXX3200AC_XXXX @ P_{sat} HPAXX3200AC_XXXX @ P_{Linear}	90 to 265 47 to 63 1120 900	VAC Hz W W
	Transmit Band Filter (Option)	Insertion Loss	-0.5	dB
	Transmit Band Noise Power Density	Without optional filter With optional filter	-50 -120	dBm/4 KHz dBm/4 KHz
KU-BAND	Frequency Range	(see options for extended band)	14.00 to 14.50	GHz
	Output Power @: P_{sat} / Two-Tone P_{Linear} (Typical / Guaranteed minimum)	HPAKU3080AC_XXXX	P_{sat} / P_{Linear} 49.0 / 46.0 (80 / 40)	dBm (W)
	Power Requirements Line Voltage Line Frequency Line Power	power factor corrected HPAKU3080AC_XXXX @ P_{sat} HPAKU3080AC_XXXX @ P_{Linear}	90 to 265 47 to 63 730 585	VAC Hz W W
	Extended Ku-Band 13.75 to 14.50 GHz	De-rate output power by 1.0 dB linearly from 14.00 - 13.75 GHz		

See specification sheet 208142 for specifications of all GaAs Mini Compact Outdoor amplifiers.



Digisat International Inc.
4195 W. New Haven Ave., Suite 15
Melbourne, FL 32904
USA
+1-321-676-5250
Email: sales@digisat.org
<http://www.digisat.org>

Common Electrical Specifications

PARAMETER	NOTES	LIMITS	UNITS
Gain	range	55-75	dB
Gain Flatness	full band (C-,X-,Ku-bands)	± 1.0	dB
Gain Slope	full band (Extended C-Band, Extended Ku-Band) per 40 MHz (C-,X-,Ku-bands)	± 1.5	dB
Gain Variation vs. Temp.	-40 °C to +55 °C	± 0.3	dB/40 MHz
Gain Adjustment	0.1 dB resolution	± 1.5	dB
Intermodulation Distortion	@ rated P _{Linear}	20	dB
AM/PM Conversion	@ rated P _{Linear}	-25	dBc
Spurious (SSPA only)	@ rated P _{Linear}	2.0	°dB
Harmonics (SSPA only)	@ rated P _{Linear}	-60	dBc
		-50	dBc
Input/Output VSWR	All units except Extended C-Band Extended C-Band units	1.30:1 1.50:1	
Noise Figure	At maximum gain (C-,X-,Ku-bands)	10	dB
Group Delay (per 40 MHz segment)	Linear	0.01	ns/MHz
	Parabolic	0.003	ns/MHz ²
	Ripple	1.0	ns p-p
Transmit Band Noise	Tx Band	-75	dBW/4 KHz
Output Power Density	Rx Band (C-,X-,Ku-bands)	-150	dBW/4 KHz
Residual AM Noise	0 - 10 KHz	-45	dBc
	10 KHz - 500 KHz	-20 (1.25 + log F)	dBc
	500 KHz - 1 MHz	-80	dBc
Phase Noise (SSPA only)	Offset frequency from carrier		
	10 Hz	-90	dBc/Hz
	100 Hz	-100	dBc/Hz
	1 KHz	-110	dBc/Hz
	10 KHz	-120	dBc/Hz
	100 KHz	-125	dBc/Hz
	1 MHz	-130	dBc/Hz
RF Power Detector	P _{sat} to (P _{sat} - 20 dBm)	20 ± 1.0	dBm

Environmental Specifications

PARAMETER	NOTES	LIMITS	UNITS
Operating Temperature	Ambient	-40 to +60	°C
Relative Humidity	Condensing	100	%
Cooling System	Integrated, forced air	265	CFM
Altitude	No temperature de-rating up to 10,000 ft, (3000 m) De-rate maximum temperature by 2 °C per 1,000 ft (300 m) beyond 10,000 ft.		
Shock	50 g p-p, 11 msec pulses		
Vibration	3g rms 30 min. 5-2000 Hz		

L-Band Operation

Teledyne Paradise Datacom offers C-, X-, and Ku-Band amplifiers with an integrated L-Band Block Up Converter.

- BUC includes Smart Reference Technology which enables the BUC to detect and switch to an externally supplied reference.
- Optional internal high stability reference
- Can lock to an externally supplied reference of 10 MHz or 50 MHz without modification.
- Wide range of external reference power (-10 dBm to +5 dBm)
- Accepts FSK monitor and control signal via IFL

Available Frequency Plans

Band	Frequency Band	IF Input	LO Frequency	RF Output	Gain Change
C	Standard C-Band	950 - 1525 MHz	4.900 GHz	5.850 - 6.425 GHz	0-4 dB
C	Extended C-Band	950 - 1825 MHz	4.900 GHz	5.850 - 6.725 GHz	0-4 dB
X	Standard X-Band	950 - 1450 MHz	6.950 GHz	7.900 - 8.400 GHz	0-2 dB
Ku	Standard Ku-Band	950 - 1450 MHz	13.050 GHz	14.00 - 14.50 GHz	0-2 dB
Ku	Extended Ku-Band	950 - 1700 MHz	12.800 GHz	13.75 - 14.50 GHz	0-2 dB

Electrical Specifications for Mini Compact Outdoor with BUC

PARAMETER	NOTES	LIMITS				UNITS
Gain	Nominal setting	75				dB
Gain Flatness	full band (C-,X-,Ku-bands)	± 2.0				dB
	full band (Extended C-, Ku-bands)	± 2.5				dB
Gain Slope	per 40 MHz (C-,X-,Ku-bands)	± 0.5				dB/40 MHz
Gain Adjusted Range		20				dB
Gain Stability	Typical Adj. Range -40 to +55 °C	55 - 75				dB
		± 1.5				dB
Phase Noise	Offset frequency from carrier	<u>Absolute max.</u>	<u>C-band (typ.)</u>	<u>X-band (typ.)</u>	<u>Ku-band (typ.)</u>	
	10 Hz	-30	-60	-60	-50	dBc/Hz
	100 Hz	-60	-80	-75	-65	dBc/Hz
	1 KHz	-70	-80	-75	-72	dBc/Hz
	10 KHz	-80	-85	-100	-90	dBc/Hz
	100 KHz	-90	-120	-110	-110	dBc/Hz
	1 MHz	-90	-125	-122	-120	dBc/Hz
Spurious	In-Band Signal Related (C-/X-/Ku-Bands) (Extended C-Band)	-50				dBc
	Close to Carrier Spurious (≤ 20 MHz)	-40				dBc
	Local Oscillator	-50				dBc
		-30				dBm
Noise Figure	At 75 dB gain setting	20				dB
Input VSWR	L-Band	1.5 : 1				
Internal Reference Option	Reference accuracy @ 25 °C Reference Stability over Temperature (-20 to +85 °C)	± 3 • 10 ⁻⁷ ± 1.5 • 10 ⁻⁸				

Mechanical Specifications

PARAMETER	NOTES	LIMITS	UNITS/DETAILS
Size	width X length X height	9.0 X 12.0 X 6.50 229 X 305 X 165	inches mm
Weight (± 3%)	Base unit 80W Ku-Band units	24.5 (11.2) 19.6 (8.9)	lbs. (kg) lbs. (kg)
Finish		Paint	White; powder coat
Connectors	RF Input RF Output - Ku-Band RF Output - C-Band RF Output - X-Band RF Output Sample Line Power Monitor and Control Link Port Redundancy Switch Auxiliary +15VDC LNB Power (500 mA)	Type N WR75 Waveguide WR137 Waveguide WR112 Waveguide Type N 3-pin MS-type 32-pin MS-type 6-pin MS type 6-pin MS-type 6-pin MS-type	Female Grooved flange (PBR-120) CPR137G flange (PDR-70) CPR112G flange (PDR-84) Female Plug Socket Socket Socket Socket

Remote Control Panel for the Mini Compact Outdoor SSPA



The RCP2-1000 is a Remote Control Panel for the Mini Compact Outdoor SSPA. It only requires 1RU of cabinet space and provides an identical local interface as exists on Teledyne Paradise Datacom Indoor Rack Mount amplifiers.

The controller communicates with the outdoor amplifier via a RS-485 link. The controller then provides a wide range of interface capability including Ethernet communications. The following communication links are available at the Remote Control Panel:

- RS-232 or Addressable RS-485 Serial Data
- Discrete (Parallel) Interface - Form C contact outputs & Opto Isolated Inputs
- Ethernet Interface - A full compliment of Ethernet Communications including UDP, SNMP, and an internal web browser.
- Local (Manual) interface via front panel LCD display

Fiber Optic Interface

Teledyne Paradise Datacom offers an Outdoor Fiber Optic Converter Module (OFM-1000) for the Mini Compact Outdoor SSPA which interfaces with a rack mountable Fiber Optic to L-Band Transceiver (RCPF-1000).

The 1RU Indoor Fiber Optic to L-Band Transceiver complements the Mini Compact Outdoor Amplifier for a complete Optical interface for the amplifier.

What distinguishes the Teledyne Paradise Datacom Fiber Optic solution is the ability to transmit and receive not only the L-Band IFL, but also a 10 MHz reference signal and an FSK signal that provides complete remote control of the amplifier. When equipped with a Teledyne Paradise Datacom Evolution Series PD25 L-Band modem, a complete base-band to optical interface is realized.

A system utilizing a Fiber Optic link can have an IFL length in excess of 1km. An optical link is also desirable in areas in which L-Band interference can degrade the performance of the system.



**Outline Drawing,
 Mini Compact
 Outdoor SSPA
 (typical)**

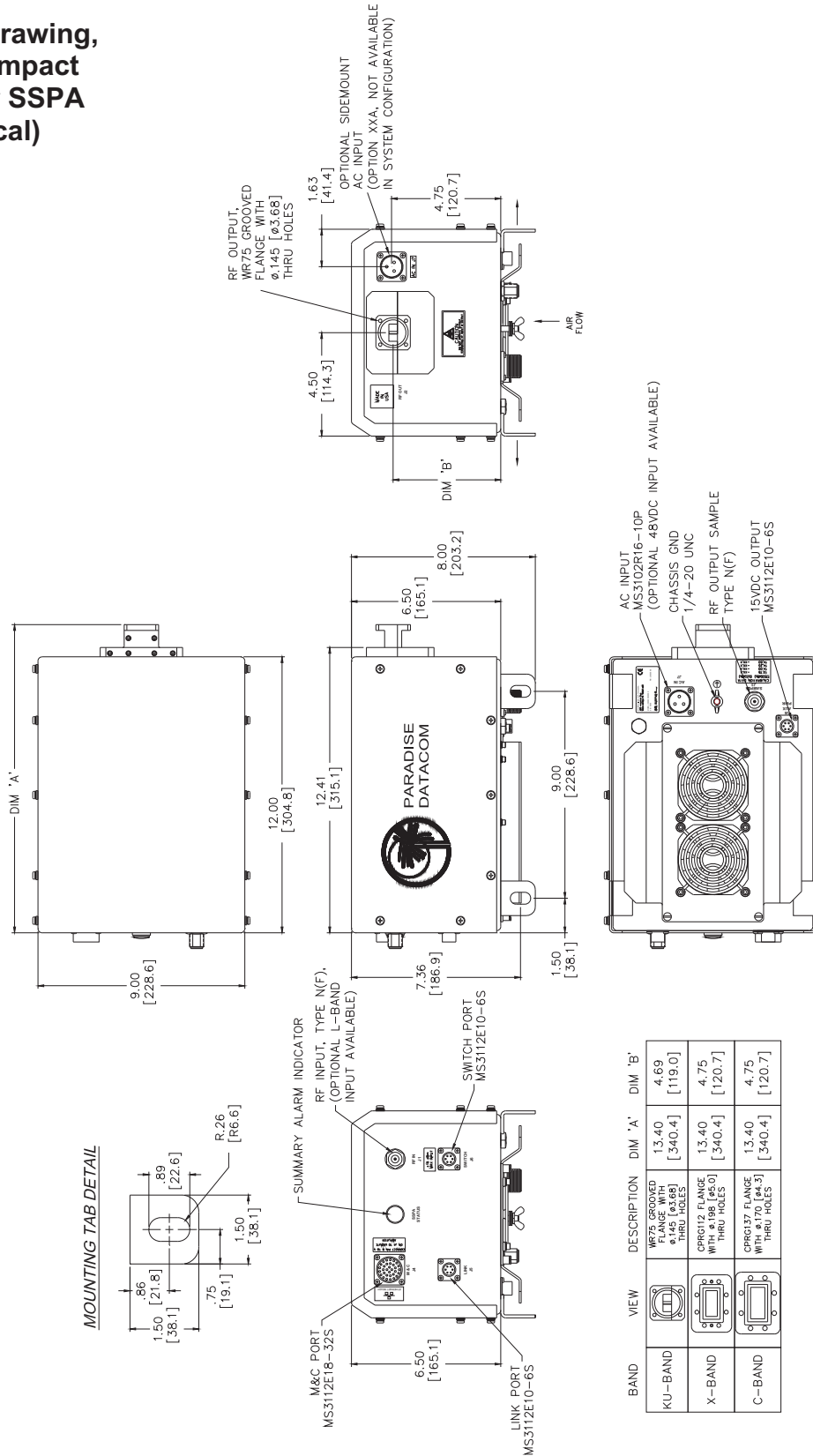

Part Number Configuration

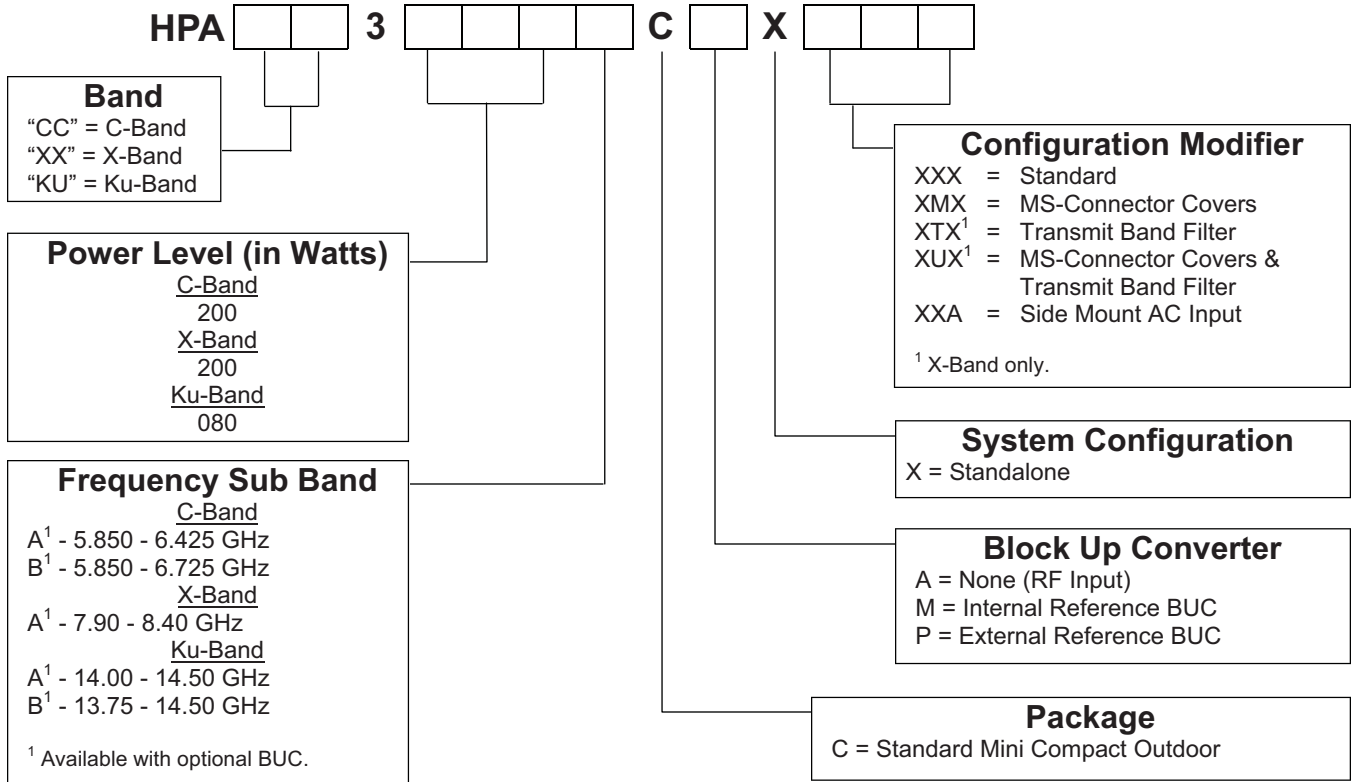

Example: A standalone 80W Extended Ku-Band Mini Compact Outdoor SSPA with an optional internal reference BUC and MS-Connector covers is part number: **HPAKU3080BCMXXMX**

Specifications listed in this document are subject to change without notice.
 X-band and Ka-band products may be subject to ITAR restrictions and should not be exported from the US without obtaining proper licensing from the appropriate government agencies.