

RF Sensing Switch w/ Hot-Swappable DC Power Supplies

General Description:

The **RSP21502FACB000** RF Sensing Switch provides two (2x1) L-Band sensing switches for LNB redundancy of both horizontal and vertical polarities on a TVRO satellite. In addition, it provides 24 VDC, enough to power four LNBs. Each L-Band sensing switch contains a single (2x1) RF detector switch which detects the presence of a 950-2150 MHz LNB satellite signal on the primary input and switches to backup (secondary) on loss of primary. The sensing switch utilizes a DPDT high frequency relay that terminates the off path with 75 Ω .

The primary RF input is filtered, amplified, and detected to operate the relays. When the input level is above the preset threshold, which is adjustable using the rear panel mounted pushbuttons, the relays are de-energized and will pass RF even under a no power condition. When the signal falls below the preset threshold, the relay is energized and the secondary signal path is selected. A front panel slide switch has been included for each sensing switch to allow manual override to the secondary input. The rear panel has been equipped with 15-pin connectors that provide an interface for contact closure alarms and remote override via contact closure.

The LNB power feature provides two separately fused power supply modules, each capable of handling 2.5 amps of current consumption. Each power supply is diode coupled to provide instantaneous redundancy should one of them fail. In addition, each power supply is in its own drawer to provide "hot-swap" capability for zero downtime.

AC and DC power status is indicated via the front panel mounted LEDs.

Note: Under a no power condition, the unit will default to the primary position.

Specifications:

Frequency:	950-2150 MHz
Impedance:	75 Ω
RF Detection Level:	-60 dBm to -20 dBm, adjustable
Maximum Input Level:	+10 dBm
Maximum Input Level (No Damage):	+20 dBm
Insertion Loss:	2.5 dB \pm 1.25 dB
Frequency Response:	\pm 1.0 dB
Return Loss:	12 dB
Isolation:	40 dB
Inputs/Outputs:	Two (2x1)
Manual Override:	Front panel mounted slide switch(es)
Threshold Adjust:	Rear panel mounted up/down pushbuttons
Power Requirements:	100-240 V~, 60/50 Hz
Power Consumption:	80 W
LNB Power:	24 V $\overline{=}$ (present on primary and secondary input ports at all times)
RF Connectors:	Type F, 75 Ω
Mechanical:	2 RU (3.50" H x 19" W x 14" D)
Weight:	7.2 lbs. gross (boxed), 4.6 lbs. net

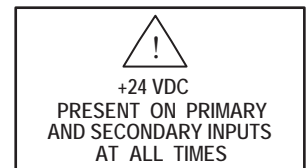



Operating Instructions:

1. Connect the appropriate RF cables to the PRIMARY, SECONDARY, and OUTPUT signal ports on the rear panel of the RSP21502FACB000.
2. Connect AC power to a 100-240 VAC power source.
3. The SECONDARY (i.e., red) LED should be on. (Note that the level control was factory preset to maximum threshold before the unit was shipped).
4. While monitoring the voltage at the LEVEL TEST PORTS using a high impedance digital voltmeter, press the LEVEL DOWN pushbutton until the PRIMARY (i.e., green) LED turns on. The following calibration chart indicates the approximate threshold voltages vs. operating primary RF power:

<u>Total RF Power (dBm)</u>	<u>Test Port Voltage (VDC)</u>
-20	+1.3
-30	+1.1
-40	+0.9
-50	+0.7
-60	+0.5

NOTE: In the event of a power interruption, the threshold level setting is maintained at its most recent setting through the use of non-volatile memory.



Digisat International Inc.
 4195 W. New Haven Ave., Suite 15
 Melbourne, FL 32904
 USA
 +1-321-676-5250
 Email: sales@digisat.org
<http://www.digisat.org>

5. ALARM OPTION

Contact closure summary alarms are provided via the rear panel mounted 15-pin quick disconnect barrier strips (Pins 1, 2, & 3). When the RSP switch is in the primary position (i.e., the green LED is on), the contact closure alarm is de-energized and will be in the COM/NC position. When the RSP switches from primary to secondary, whether by local manual override, remote override, or loss of RF on primary, an alarm output is triggered (the contact closure alarm is energized and switches to the COM/NO position).

6. LOCAL OVERRIDE

Front panel mounted slide switches provide local manual override to the secondary input. There will be a contact closure alarm when the manual override switches the RF switch to the secondary input.

7. REMOTE OVERRIDE

Remote overrides are provided via the rear panel mounted 15-pin connectors ("GND" and "CTL") (Pins 4 & 5). Grounding the "CTL" pin will cause the RSP to switch to the secondary input. There will be 5 VDC present on the control pin under normal operating conditions (i.e., when the RSP is in the primary position). There will be a contact closure alarm when the remote override switches the RSP to the secondary input.

8. The front panel of the RSP21502FACB000 has power supply indicators and test ports for monitoring the power supplies. Both AC inputs must be activated for DC redundancy. For true AC redundancy, separate AC sources must be applied.

The two power supply modules are on individual drawers to provide easy replacement of a failed module. The failed module can be replaced while the RSP is in operation, resulting in zero downtime. Additional modules can be purchased separately to allow for spares.

9. Contact closures are provided via the rear panel mounted 15-pin connectors for remote alarm notification of failed power supplies (Pins 6, 7, & 8). Upon powering up the RSP, relay coils will energize. If a DC supply fails, the relay will revert to its normally closed position, indicating a failure.

Pinouts for the rear panel mounted 15-pin connectors are shown below:

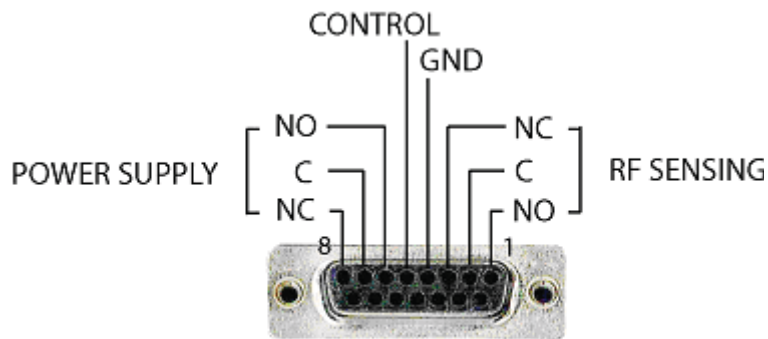

THE FOLLOWING PROCEDURE SHOULD BE STRICTLY ADHERED TO WHEN REPLACING A FAILED POWER SUPPLY MODULE:

1. To power down a failed module, turn off the appropriate switch on the rear panel, (switch AC1 for module 1, switch AC2 for module 2). Wait 5 minutes for the capacitors to discharge.
2. Remove the front panel module mounting screws.
3. Using the handle, slowly slide the module out of the enclosure (use caution, the power supply module may be very hot).
4. Carefully slide the replacement module into the rack enclosure. Be sure to properly align the plug on the rear of the replacement power supply with the socket inside the power supply chassis. If the connector is properly aligned, the replacement module's faceplate will set flush against the faceplate of the power supply chassis.
5. Replace the front panel mounting screws.
6. Turn the power switch back on.

IMPORTANT SAFETY INSTRUCTIONS

- Read these instructions.
- Keep these instructions.
- Heed all warnings.
- Follow all instructions.
- Clean only with dry cloth.
- Do not block any ventilation openings. Install in accordance with the manufacturer's instructions.
- Do not defeat the safety purpose of the polarized or grounding-type plug. A polarized plug has two blades with one wider than the other. A grounding type plug has two blades and a third grounding prong. The wide blade or the third prong are provided for your safety. If the provided plug does not fit into your outlet, consult an electrician for replacement of the obsolete outlet.
- Only use attachments/accessories specified by the manufacturer.
- Refer all servicing to qualified service personnel. Servicing is required when the apparatus has been damaged in any way, such as power-supply cord or plug is damaged, liquid has been spilled or objects have fallen into the apparatus, the apparatus has been exposed to rain or moisture, does not operate normally, or has been dropped.

Attention: Contient une pile de lithium. Risque d'explosion dans le cas où la pile ne serait pas correctement remplacée. Remplacer uniquement avec une pile semblable ou équivalente au type de pile recommandé par le fabricant.

Warning

- To reduce the risk of fire or electric shock, do not expose this apparatus to rain or moisture.
- This apparatus must be earth grounded. Use the three wire grounding type line cord supplied with the product.
- Do not open the unit - risk of electric shock inside.