



OUTDOOR SATELLITE ROUTER

UHP-1200



GENERAL DESCRIPTION AND INSTALLATION GUIDE

DOCUMENT RELEASE 3.2

[UHP.OR32.EN]

AUGUST 2015

CONTENT

Acronyms and Abbreviations	4
Introduction	6
Required level of qualification	6
Document version and applicability.....	6
Copyright.....	6
1. General description	7
1.1 System overview.....	7
1.2 Measurement equipment, tools and accessories	7
1.3 Labeling and sealing.....	7
1.4 Packaging and content.....	8
1.5 Description and principles of operation	8
1.5.1 Overview.....	8
1.5.2 Power connector (DC IN)	9
1.5.3 LAN interface connector.....	9
1.5.4 IF Rx input	9
1.5.5 IF Tx Modulator output.....	9
2. Operations	10
2.1 Operational limits	10
2.2 Preparation for use.....	10
2.2.1 Unpacking	10
2.2.2 Installation	10
2.2.3 Connecting to external devices	10
2.2.4 Powering on.....	11
2.2.5 Local access to router via HTTP interface.....	11
2.2.6 Remote Telnet access	11
2.2.7 Command Interface	11
3. Operations	12
3.1 Software updates.....	12
3.2 Powering off	12
3.3 Safety instructions for operations	12
4. Troubleshooting	13
5. STORAGE, TRANSPORTATION AND DISPOSAL.....	15

FIGURES

Figure 1 Structure of UHP Manuals.....	6
Figure 2 UHP-1200 Outdoor Satellite Router.....	7
Figure 3 Labeling of UHP-1200 satellite router.....	8
Figure 4 UHP-1200 Architecture	8
Figure 5 UHP-1200 series modem – rear view.....	9

TABLES

Table 1 Operational limits	10
Table 2 Pinout of 8P8C LAN interface (RJ45)	10
Table 3 Troubleshooting guide.....	13

ACRONYMS AND ABBREVIATIONS

16APSK	16 Amplitude and Phase-shift keying or Asymmetric Phase-shift keying, (APSK), is a digital modulation scheme that conveys data by changing, or modulating, both the amplitude and the phase of a reference signal (the carrier wave).
32APSK	32 Amplitude and Phase-shift keying or Asymmetric Phase-shift keying, (APSK), is a digital modulation scheme that conveys data by changing, or modulating, both the amplitude and the phase of a reference signal (the carrier wave).
8PSK	Phase-shift keying (PSK) is a digital modulation scheme that conveys data by changing, or modulating, the phase of a reference signal (the carrier wave).
AGC	Automatic Gain Control
BCH	BCH code is a multilevel cyclic variable-length digital error-correcting code used for correcting multiple random error patterns. BCH codes may also be used with multilevel phase-shift keying whenever the number of levels is a prime number or a power of a prime number.
BUC	Block Up-Converter (BUC) is used in the transmission (uplink) of satellite signals. It converts a band (or "block") of frequencies from a lower frequency to a higher frequency.
C/N	Carrier-to-noise ratio, often written as CNR or C/N, is the signal-to-noise ratio (SNR) of a modulated signal.
CRTP	Compressing IP/UDP/RTP Headers for Low-Speed Serial Links
DAMA	Demand Assigned Multiple Access. Channel establishment on demand.
DSCP	Differentiated Services Code Point (DSCP) is a 6-bit field in the header of IP packets for packet classification purposes. DSCP replaces the outdated IP precedence, a 3-bit field in the Type of Service byte of the IP header originally used to classify and prioritize types of traffic
DVB	Digital Video Broadcasting (DVB) is a suite of internationally accepted open standards for digital television.
Eb/No	Eb/NO (the energy per bit to noise power spectral density ratio) is an important parameter in digital communication or data transmission. It is a normalized signal-to-noise ratio (SNR) measure, also known as the "SNR per bit". It is especially useful when comparing the bit error rate (BER) performance of different digital modulation schemes without taking bandwidth into account.
EIRP	Effective Isotropically Radiated Power
ETSI	The European Telecommunications Standards Institute (ETSI) is an independent, non-profit, standardization organization in the telecommunications industry (equipment makers and network operators) in Europe, with worldwide projection.
FEC	In telecommunication and information theory, forward error correction (FEC) is a system of error control for data transmission, whereby the sender adds redundant data to its messages, also known as an error-correction code.
Frame	TDMA service packet describing which station should transmit in which time slot . Generated ~10 times per second.
Hard priority	Method of transmission queues handling when packets from lower priority queue are not transmitted until all packets from higher priority queue are transmitted.
HTTP	Hypertext Transfer Protocol (HTTP) is an application-level protocol for distributed, collaborative, hypermedia information systems.
HUB	Central Station of satellite network that is managing all the terminals and resources
Hubless	Special mode of operation when all stations are transmitting to one TDMA carrier and all receiving this carrier.
HW	Hardware
ICMP	The Internet Control Message Protocol (ICMP) is used by networked devices to send error messages—indicating, for instance, that a requested service is not available or that a host or router could not be reached.
IESS	Intelsat Earth Station Standards
IFL	Connection from the indoor equipment (modem/router) to the outdoor equipment at the antenna normally involves two inter-facility (IFL) cables.
IGMP	The Internet Group Management Protocol (IGMP) is a communications protocol used by hosts and adjacent routers on IP networks to establish multicast group memberships.
Inroute	Channel from stations to hub.
IP	IP is the usual abbreviation for Internet Protocol.
LDPC	Low-density parity-check (LDPC) code is a linear error correcting code, a method of transmitting a message over a noisy transmission channel, and is constructed using a sparse bipartite graph.
LNB	Low-noise block converter is the receiving converter installed at satellite antenna.
Local oscillator	Oscillator built into RF block converter (BUC or LNB). Value of LO is usually written on block enclosure or in datasheet.
Long frames	DVB-S2 frames 64800 bits long (including FEC). Require slightly lower C/N than short frames.
Master	Main station of Hubless network. Master allocates bandwidth and performs stations acquisition.
MCPC	Multiple channels per carrier. All TDM carriers generated by UHP can be treated as MCPC. Even if they are called SCPC.
Mesh	Capability of station allowing to receive other stations via TDMA link.
MF-TDMA	TDMA working on several RF channels simultaneously. All MF channels work as one aggregate TDMA channel.
MODCOD	Modulation and coding mode.
NMS	Network Management System
Node Station	Terminal of satellite network which is able to receive information directly from other network terminals
ODU	Out-Door Unit
Outroute	Forward TDM channel (MCPC) from HUB to stations.
QPSK	Phase-shift keying (PSK) is a digital modulation scheme that conveys data by changing, or modulating, the phase of a reference signal (the carrier wave).
RF level	Absolute RF level of entire signal (carrier + adjacent carriers) expressed in dBm.
RSV	Reed–Solomon error correction is an error-correcting code that works by oversampling a polynomial constructed from the data.

SCPC	Single Channel Per Carrier
Short frames	DVB-S2 frames 16200 bits long (including FEC). Advisable to use at lower symbol rates. Produce less delay than Long frames.
SNMP	Simple Network Management Protocol
SNTP	Simple Network Time Protocol (SNTP) is a protocol and software implementation for synchronizing the clocks of computer systems over packet-switched, variable-latency data networks.
SNR	Signal-to-noise ratio is an electrical engineering measurement defined as the ratio of a signal power to the noise power corrupting the signal.
SR	Symbol Rate
Star	Type of network with one central station (hub) and several peripheral stations.
SW	Software
TDM	Time Division Multiplexing
TDMA	Time Division Multiple Access
Telnet	Telecommunication Network (Telnet) is a network protocol used on the Internet or local area networks to provide a bidirectional interactive communications facility. Typically, telnet provides access to a command-line interface on a remote host via a virtual terminal connection.
Terminal	Earth Stations (usually VSAT) operated under management of network HUB
TFTP	Trivial File Transfer Protocol (TFTP) is a file transfer protocol, with the functionality of a very basic form of File Transfer Protocol (FTP).
Timestamp	Time format used by UHP. Plus sign at the beginning (+HH:MM:SS or +NN d HH:MM:SS)denotes relative time from some event or UHP start-up. If UHP has time synchronized to hub or SNTP absolute time can be displayed. Time zone affects absolute time.
Time-slot	Time interval for station transmission.
UDP	The User Datagram Protocol (UDP) is the set of network protocols used for the Internet. With UDP, computer applications can send messages, in this case referred to as datagram, to other hosts on an Internet Protocol (IP) network without requiring prior communications to set up special transmission channels or data paths.
USB	USB (Universal Serial Bus) is a specification to establish communication between devices and a host controller (usually personal computers).
VLAN	A virtual LAN, commonly known as a VLAN, is a group of hosts with a common set of requirements that communicate as if they were attached to the same broadcast domain, regardless of their physical location.
VoIP	Voice over Internet Protocol (VoIP) is a general term for a family of transmission technologies for delivery of voice communications over IP networks such as the Internet or other packet-switched networks.
VSAT	Very Small Aperture Terminal – satellite earth station with small-size antenna
WFQ	Weighted fair queuing. Method of proportional division of bandwidth between transmission queues.
X-modem	Simple file-transfer protocol

INTRODUCTION

This document presents a general description of the UHP-1200 series satellite routers and is intended for familiarization with the system capabilities and specifications. This manual is applicable to all the key modes of the router operations.

Required level of qualification

This manual is intended for engineering personnel operating VSAT networks. Such specialists should have adequate educational credentials in the field of electronics and sufficient experience and skills in data networks administration and satellite systems.

Document version and applicability

UHP VSAT platform is based on the universal satellite router UHP, which is available in different fully-compatible hardware modifications. UHP satellite router is a basic element of any network architecture and can be used in any combinations and at any hierarchy level. Router functional capabilities and its operating modes are determined by the installed software and its configuration.

This manual is applicable to all UHP-1200 series outdoor satellite routers (previously known also as UHP-1000-OD) with software release 3.2 or higher. When ordering this document, please specify its ID: [UHP.OR32.EN].

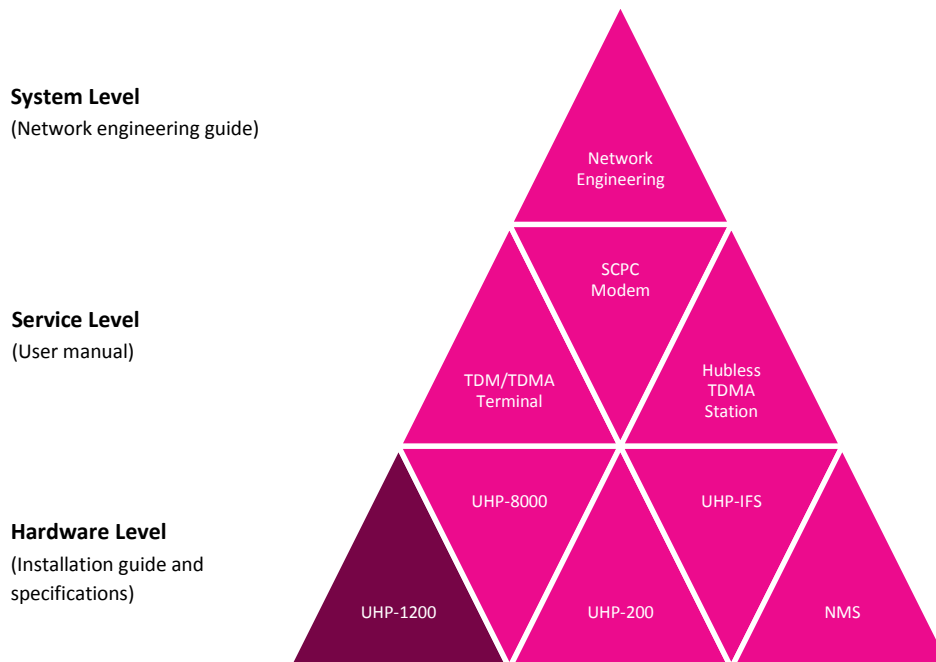

Figure 1 Structure of UHP Manuals

Copyright

The content of this document is the intellectual property of UHP Networks Inc. (referred to below as UHP Networks). Copying or quoting this description as a whole or of any part of it without a written permission from UHP Networks is prohibited.

1. GENERAL DESCRIPTION

1.1 System overview

UHP satellite routers are essentially a universal solution for geographically distributed VSAT-class satellite communication networks. UHP routers can be used to organize simple point-to-point channels, “star”- and “mesh”-topology networks with several hierarchy levels and bandwidth-on-demand capabilities.

UHP VSAT platform is based on many innovation technologies. It was developed using long-term experience in satellite service provisioning. Nowadays electronics achievements made it possible to make VSAT platform compact and assure its efficiency and reach functionality.

Weatherproof UHP-1200 satellite router can be installed outdoors, for example, directly on the antenna. IP67 design ensures reliable operation over a wide temperature range.



Figure 2 UHP-1200 Outdoor Satellite Router

Technical characteristics are given in the appropriate product specification sheets.

1.2 Measurement equipment, tools and accessories

The router can be accessed via LAN. Standard computer (notebook) is required to configure and monitor status of UHP-1200 satellite router. The computer must be equipped with a LAN interface, and also have the following software installed:

- Internet browser (WEB browser)
- Telnet Client (optional)
- The Terminal (e.g.: Hyperterminal, included in the OS Windows) (optional)

1.3 Labeling and sealing

The product is marked with the unique Serial Number, as well as Part Number on the bottom of the router case.

The warranty seals are located on the bottom of the product, at the junction of the two parts of the case. Product warranty will automatically void if such labels have been removed, modified or damaged.

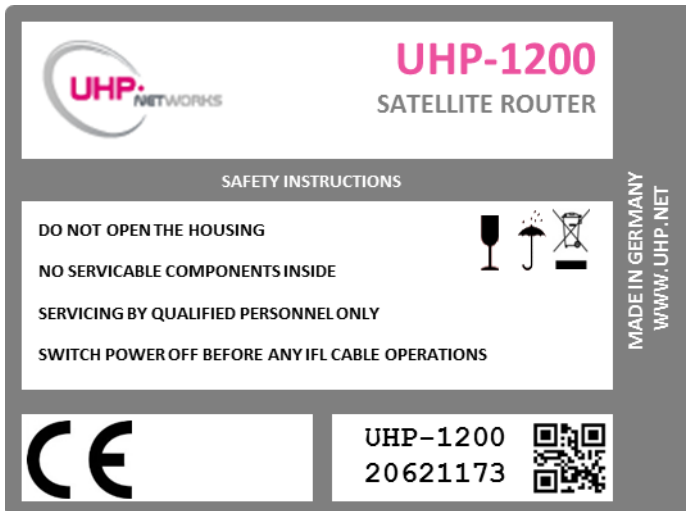

Figure 3 Labeling of UHP-1200 satellite router

1.4 Packaging and content

Standard UHP-1200 package includes:

1. Satellite router UHP-1200;
2. Installation kit.

It is recommended to keep original packaging throughout the entire lifetime. Conservation, storage and transportation of the terminal must be in original packaging.

1.5 Description and principles of operation

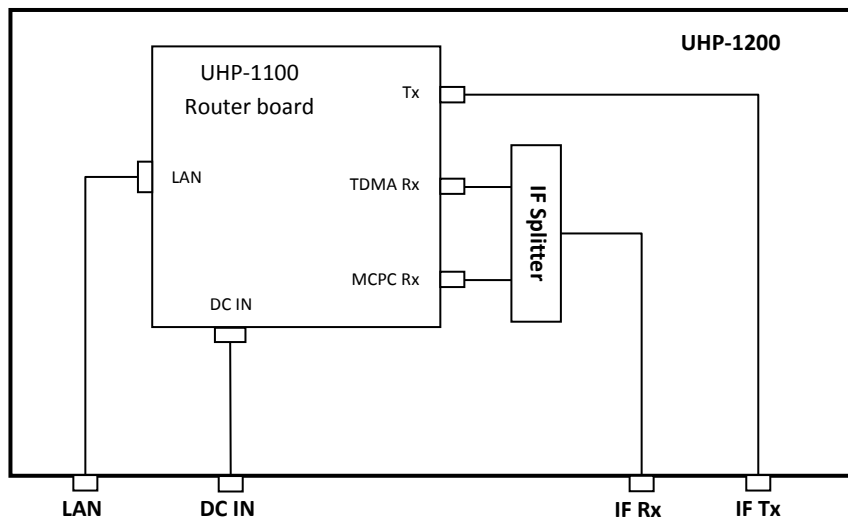

Figure 4 UHP-1200 Architecture

1.5.1 Overview

UHP-1200 Satellite router has a weatherproof, sealed housing and without any serviceable parts inside. External devices should be connected through connectors on the bottom interface of the device. The LAN port is used both for connection to the user’s network and for configuration and control of the router.



Figure 5 UHP-1200 series modem – rear view

1.5.2 Power connector (DC IN)

UHP-1200 router is powered with 24 VDC. AC/DC Power supply adaptor is not supplied. The router can be powered from different DC power sources (batteries, DC-DC converter). The router can provide power to RF hardware within the current according to the specifications of the router.

1.5.3 LAN interface connector

LAN connector is purposed for connecting to Ethernet switch using a straight cable. Bit rate 10 or 100 and duplex mode are software selectable.

1.5.4 IF Rx input

This interface is intended to connect the router to the LNB. The received signal via the built-in splitter (see Figure 4) is fed to a DVB and TDMA demodulators of the router. The input, on the router side, can be fed with 18 VDC power supply. Whether power source in on or off, the input can withstand external voltage up to 50 VDC (power supply circuit is provided with a diode). Power supply circuit is protected with a thermal fuse operating in case of short circuiting. After short circuiting is removed it may be required to disconnect load from Rx inputs for several seconds so as to allow the fuse to return to its initial state. Cable length and cable quality (losses level) can affect the quality and possibility of receiving signals.

THE TOTAL CURRENT CONSUMED BY EXTERNAL EQUIPMENT THROUGH BOTH RX INPUTS SHOULD NOT BE IN EXCESS OF 750 MA. NORMALLY, CURRENT CONSUMPTION BY DRO LNB - 150 MA, PLL LNB - 500 MA.

1.5.5 IF Tx Modulator output

IF TX OUTPUT CAN FEATURE 24 VDC WITH A HIGH SHORT-CIRCUIT CURRENT. SHORT CIRCUITING CAN CAUSE SPARKLE SPREAD AND BURNS. THIS VOLTAGE CAN DAMAGE MEASUREMENT EQUIPMENT IF IT IS NOT PROTECTED AT ITS INPUTS. SUPPLYING EXTERNAL VOLTAGE TO THIS CONNECTOR IS OBJECTIONABLE AND SUPPLYING MORE THAN 24 V IS PROHIBITED.

UHP-1200 modulator is compatible with most satellite transmitters/converters (BUC). Modulator is connected directly to the IF Tx connector. The router provides 24 VDC power supply to the BUC and 10 MHz reference signal. UHP-1200 is not provided with a separate protection on the transmitter power supply circuitry. Use is made of current protection for the power supply adapter. In case of a short circuit the router is de-energized and then gets restarted. If power supply is switched on in the configuration, restarts continue at 5 seconds interval until short circuiting is removed.

ANY OPERATIONS WITH IF TX CABLE SHOULD BE PERFORMED WITH 24 V SUPPLY VOLTAGE TURNED OFF. OTHERWISE, SELF-INDUCTION ACROSS A LONG CABLE CAN DAMAGE THE TRANSMITTER AND/OR THE ROUTER.

2. OPERATIONS

2.1 Operational limits

Table 1 Operational limits

#	Parameter	Limits	
		Minimum	Maximum
1	Router DC Input voltage	23 VDC	25 VDC
2	Output current at Tx Out interface	-	2 A
3	Input voltage on the Tx Out interface	-	24 V
4	Output current at Rx SCPC or RX TDMA	-	0,75 A
5	Input voltage on other interfaces		18 V
6	Operational temperature	0 C	+40 °C
7	Relative humidity (@ 25°C)	0%	90%
8	Atmospheric pressure (mm Hg)	720	770
9	Mechanical impacts (acceleration with an amplitude not exceeding 1,25 mm): - in a range 0,5 – 15 Hz: - in a range 15-40 Hz: - in a range 40-300 Hz:		2,45 m/s 5,88 m/s 14,7 m/s

2.2 Preparation for use

2.2.1 Unpacking

Before opening the packaging please check a safety of transport container. If there is any visible damage of packaging you should keep it as long as the delivered equipment will be properly tested.

2.2.2 Installation

UHP-1200 Router is designed for installation on any flat, stable surface or on an antenna mount with the included universal installation kit. The router should be installed in a place protected from direct sunlight.

Table 2 Pinout of 8P8C LAN interface (RJ45)

Пин	Назначение
1.	Rx +
2.	Rx -
3.	Tx+
4.	DC +
5.	DC +
6.	Tx -
7.	DC -
8.	DC -

2.2.3 Connecting to external devices

All wire connections must be performed before powering up the router. Cable connectors should be screwed to the router without use of any mechanical instruments. Please, avoid excessive force when connecting IF cables.

WARNING! DO NOT CONNECT OR DISCONNECT ANY CONNECTING CABLES TO THE ROUTER WITH THE POWER ON. THIS CAN LEAD TO A FAILURE OF THE ROUTER AND CONNECTED DEVICES.

2.2.4 Powering on

In a few seconds after powering the router it is ready for use. The actual status of the router can be checked using its web interface (via LAN). With factory setting the router is configured as TDM/TDMA terminal. The router requires change of mode of operation (if necessary) and/or configuration of respective network parameters before login into satellite networks. The easiest way to configure the router is using its HTTP access via its LAN port.

The router can be reset by short (2-3 sec.) power interruption.

2.2.5 Local access to router via HTTP interface

HTTP (web) interface allows configuration key parameters and monitoring its actual status of the router. Local Web page of the router can be accessed from any Internet browser.

By default, UHP-1200 router is configured with IP-address 192.168.222.222 with mask 255.255.255.248 (/29). Respectively, the computer should be configured with an address, e.g. 192.168.222.217 with the same mask.

In case the satellite routers have been preconfigured at the factory on customer's request such routers may have different default IP address. In such case the respective IP addresses will be listed in the passport of the router. If it's impossible connecting the router with any of specified addressed please reset the router to factory settings.

2.2.6 Remote Telnet access

Remote access to the configuration can be performed using Telnet protocol. The connection can be provided to any of IP addresses that are set on the router. UHP-1200 supports simultaneously only one Telnet session. In order the hang session does not block access to the device forever in case on non-activity (pressing ENTER key), the router auto-terminates the session after a certain time of inactivity. The time can be set in the configuration, and by default it is 10 minutes.

2.2.7 Command Interface

Please refer to the Command Interface manual applicable for the respective version of SW and activated mode of operation of the UHP router. The Command Interface manuals are available for download and online use on the website: <http://www.uhp.net>.

3. OPERATIONS

UHP Routers belong to the class of unattended equipment and during its operation does not require any special staff exploitation. When operated as SCPC station or TDM/TDMA terminal the satellite router does not require any changes of settings or it is configured remotely from the Hub. The tasks of operational staff are limited to the following:

- Monitoring of climatic environment of operation, ensuring the absence of dust, preventing the ingress of moisture on the surface of the device. Should provide unrestricted air access to router for cooling.
- Cables connected to the device must not suffer any significant impact on the connections of the router. All connectors must be properly attached and secured.

3.1 Software updates

One of the key advantages of UHP satellite routers is the ability to extend the functionality by updating the software. Software updates also include fixes for known bugs and improving the algorithms of the system.

3.2 Powering off

The router can be powered off by disconnecting its DC cord from the power supply.

3.3 Safety instructions for operations

- ☞ Connect and disconnect any cables only when router is powers off;
- ☞ The router must have a reliable grounding;
- ☞ Do not try to repair the router and not use it for other purposes;
- ☞ There no serviceable components inside, opening a housing is not permitted;
- ☞ Servicing by qualified personnel only.

4. TROUBLESHOOTING

Table 3 Troubleshooting guide

Symptoms	Possible reasons	Actions
Router doesn't work	DC power beyond the limits of allowed values	Check DC power voltage
	Power cord is broken	Check the power cable and output voltage. Replace a cable.
Router restarts every 3-5 seconds.	Short-circuit in transmit cable	Disconnect and check Tx cable
	Software failure	Reset software to factory defaults
No reception from the satellite (indicator LOCK is off, single flashes of ERROR indicator)	Incorrect configuration	Check Rx frequency and symbol rate.
	IF cable failure	Check Rx cable and make sure that its connectors are properly connected to the LNB and the router.
	LNB is not powered	Check if LNB power is switched on Disconnect Rx IF cable from LNB and make sure that 12-18 VDC is available on the connector. Check Rx level in the statistic of the demodulator.
	No carrier on the satellite or its level is insufficient.	Verify availability of the carrier and its level with spectrum analyzer. Contact Hub administrator and investigate if the carrier is properly transmitting and local weather conditions not attenuate the signal.
	Low Rx carrier level	Measure carrier signal to noise level with a spectrum analyzer. Verify if antenna is properly pointed to the satellite and there no obstacles in the direction to the satellite. Check the integrity of the film of antenna's feed horn and absence of moisture in it.
LNB failure	Replace LNB to the spare one	
High rate of errors of Rx path	Bad weather conditions	The quality of reception may temporary decrease during intensive rainfall, for, thunderstorm cloudiness. Check if there is no snow or ice on the antenna surface and on the feed horn.
	Low signal to noise level	Check C/N in demodulator's statistics. Verify if antenna is properly pointed to the satellite and there no obstacles in the direction to the satellite. Check the integrity of the film of antenna's feed horn and absence of moisture in it.
	Low Rx carrier level Interferences	Check Eb/No in demodulator's statistics. Contact Hub administrator and investigate if the carrier is properly transmitting and local weather conditions not attenuate the signal
Station is not transmitting	Wrong network setting	Check Tx frequency and symbol rate of the modulator. Make sure that transmission is enabled

Symptoms	Possible reasons	Actions
	Transmission of the terminal is not allowed by Hub (only for TDM/TDMA terminal)	Contact Hub administrator
Station is not transmitting	IF Tx cable failure	Check Tx cable and make sure that its connectors are properly connected to the BUC and the router.
	BUC is not powered	Check if BUC power is switched on Disconnect Tx IF cable from BUC and make sure that 24 VDC is available on the connector.
	BUC failure	Replace the BUC on the spare one
Other symptoms	Other reasons	Contact your dealer or service center

In many cases, reinstalling system software allows to restore a satellite router functionality, which may need reset to the factory default configuration.

If the recovery of software cannot be implemented successfully, or if this operation does not eliminate the defect, it is necessary to illuminate the faulty device and replace it by new device.

5. STORAGE, TRANSPORTATION AND DISPOSAL

Storage and transportation of satellite routers must be performed in original packaging. Equipment can be stored and transported in pallet with height not more than 10 devices.

Storage and transportation should comply with the following conditions:

- - limiting low temperature of storage (minus 40 ± 2) ° C;
- - limiting high temperature of storage (50 ± 2) ° C.
- - atmospheric pressure $720 \div 770$ mm. Hg.

Utilization of satellite routers must be in accordance with the rules for disposal of industrial or consumer electronics in accordance with applicable law.



Digisat International Inc.
4195 W. New Haven Ave., Suite 15
Melbourne, FL 32904
USA
+1-321-676-5250
Email: sales@digisat.org
<http://www.digisat.org>