



DUAL SATELLITE ROUTER

UHP-8000



Romantis UHP-8000

GENERAL DESCRIPTION AND INSTALLATION GUIDE

DOCUMENT RELEASE 3.2

[UHP.8R32.EN]

JANUARY 2015

CONTENT

Acronyms and Abbreviations	4
Introduction	6
Required level of qualification	6
Document version and applicability.....	6
Copyright.....	6
1. General description	7
1.1 System overview.....	7
1.1.1 Purpose.....	7
1.2 Router composition	7
1.3 Measurement equipment, tools and accessories	7
1.4 Labeling and sealing.....	8
1.5 Packaging and content.....	8
1.6 Description and principles of operation	8
1.6.1 Overview	8
1.6.2 Power connector (Power input A/B)	9
1.6.3 USB CONSOLE (USB A/B)	9
1.6.4 IF input (RX)	9
1.6.5 LAN interface connector (LAN A/B).....	10
1.6.6 Modulator output (TX).....	10
1.6.7 “ERROR” Indicator	11
1.6.8 “STATUS” Indicator	11
1.6.9 “LOCK” Indicator.....	11
1.6.10 “TDMA” Indicator	11
1.6.11 “SCPC” Indicator	12
1.6.12 “TX” Indicator	12
2. Operations	13
2.1 Operational limits	13
2.2 Preparation for use.....	13
2.2.1 Unpacking	13
2.2.2 Installation	13
2.2.3 Connecting to external devices	13
2.2.4 Powering on.....	14
2.2.5 Local access to router via HTTP interface.....	15
2.2.6 Local access via USB.....	15
2.2.7 Remote Telnet access	15
2.2.8 Command Interface.....	15
3. Operations	16

3.1	Software updates.....	16
3.2	Powering off	16
3.3	Safety instructions for operations	16
3.4	Actions in case of fire.....	16
4.	Troubleshooting	17
4.1	Replacement of modules.....	18
4.1.1	Common recommendations.....	18
4.1.2	Safety instructions	18
5.	STORAGE, TRANSPORTATION AND DISPOSAL.....	19

FIGURES

Figure 1	Structure of UHP Manuals.....	6
Figure 2:	Standard labeling of satellite router	7
Figure 3:	UHP-8000 satellite router – rear view	8
Figure 4	Standard internal configuration of UHP-8000 router	8
Figure 5	Internal configuration of UHP-8000 in Hub (HBIC) mode	9
Figure 6	Internal configuration of UHP-8000 in dual Inroute (ICIC) mode	10
Figure 7	Satellite Router UHP-8000 series front view.....	11
Figure 8	Example of router’s connection in a basic mode of operation.	14
Figure 9	Example of router's connection in Hub mode (with 3 Inroutes).....	14

TABLES

Table 1	Operational limits	13
Table 2	Troubleshooting guide.....	17

ACRONYMS AND ABBREVIATIONS

16APSK	16 Amplitude and Phase-shift keying or Asymmetric Phase-shift keying, (APSK), is a digital modulation scheme that conveys data by changing or modulating both the amplitude and the phase of a reference signal (the carrier wave).
32APSK	32 Amplitude and Phase-shift keying or Asymmetric Phase-shift keying, (APSK), is a digital modulation scheme that conveys data by changing, or modulating, both the amplitude and the phase of a reference signal (the carrier wave).
8PSK	Phase-shift keying (PSK) is a digital modulation scheme that conveys data by changing or modulating the phase of a reference signal (the carrier wave).
AGC	Automatic Gain Control
BCH	BCH code is a multilevel cyclic variable-length digital error-correcting code used for correcting multiple random error patterns. BCH codes may also be used with multilevel phase-shift keying whenever the number of levels is a prime number or a power of a prime number.
BUC	Block Up-Converter (BUC) is used in the transmission (uplink) of satellite signals. It converts a band (or "block") of frequencies from a lower frequency to a higher frequency.
C/N	Carrier-to-noise ratio, often written as CNR or C/N, is the signal-to-noise ratio (SNR) of a modulated signal.
CRTP	Compressing IP/UDP/RTP Headers for Low-Speed Serial Links
DAMA	Demand Assigned Multiple Access. Channel establishment on demand.
DSCP	Differentiated Services Code Point (DSCP) is a 6-bit field in the header of IP packets for packet classification purposes. DSCP replaces the outdated IP precedence, a 3-bit field in the Type of Service byte of the IP header originally used to classify and prioritize types of traffic
DVB	Digital Video Broadcasting (DVB) is a suite of internationally accepted open standards for digital television.
Eb/No	Eb/NO (the energy per bit to noise power spectral density ratio) is an important parameter in digital communication or data transmission. It is a normalized signal-to-noise ratio (SNR) measure, also known as the "SNR per bit". It is especially useful when comparing the bit error rate (BER) performance of different digital modulation schemes without taking bandwidth into account.
EIRP	Effective Isotropically Radiated Power
ETSI	The European Telecommunications Standards Institute (ETSI) is an independent, non-profit, standardization organization in the telecommunications industry (equipment makers and network operators) in Europe, with worldwide projection.
FEC	In telecommunication and information theory, forward error correction (FEC) is a system of error control for data transmission, whereby the sender adds redundant data to its messages, also known as an error-correction code.
Frame	TDMA service packet describing which station should transmit in which time slot . Generated ~10 times per second.
Hard priority	Method of transmission queues handling when packets from lower priority queue are not transmitted until all packets from higher priority queue are transmitted.
HTTP	Hypertext Transfer Protocol (HTTP) is an application-level protocol for distributed, collaborative, hypermedia information systems.
HUB	Central Station of satellite network that is managing all the terminals and resources
Hubless	Special mode of operation when all stations are transmitting to one TDMA carrier and all receiving this carrier.
HW	Hardware
ICMP	The Internet Control Message Protocol (ICMP) is used by networked devices to send error messages—indicating, for instance, that a requested service is not available or that a host or router could not be reached.
IESS	Intelsat Earth Station Standards
IFL	Connection from the indoor equipment (modem/router) to the outdoor equipment at the antenna normally involves two inter-facility (IFL) cables.
IGMP	The Internet Group Management Protocol (IGMP) is a communications protocol used by hosts and adjacent routers on IP networks to establish multicast group memberships.
Inroute	Channel from stations to hub.
IP	IP is the usual abbreviation for Internet Protocol.
LDPC	Low-density parity-check (LDPC) code is a linear error correcting code, a method of transmitting a message over a noisy transmission channel, and is constructed using a sparse bipartite graph.
LNB	Low-noise block converter is the receiving converter installed at satellite antenna.
Local oscillator	Oscillator built into RF block converter (BUC or LNB). Value of LO is usually written on block enclosure or in datasheet.
Long frames	DVB-S2 frames 64800 bits long (including FEC). Require slightly lower C/N than short frames.
Master	Main station of Hubless network. Master allocates bandwidth and performs stations acquisition.
MCPC	Multiple channels per carrier. All TDM carriers generated by UHP can be treated as MCPC. Even if they are called SCPC.
Mesh	Capability of station allowing to receive other stations via TDMA link.
MF-TDMA	TDMA working on several RF channels simultaneously. All MF channels work as one aggregate TDMA channel.
MODCOD	Modulation and coding mode.
NMS	Network Management System
Node Station	Terminal of satellite network which is able to receive information directly from other network terminals
ODU	Out-Door Unit
Outroute	Forward TDM channel (MCPC) from HUB to stations.
QPSK	Phase-shift keying (PSK) is a digital modulation scheme that conveys data by changing, or modulating, the phase of a reference signal (the carrier wave).
RF level	Absolute RF level of entire signal (carrier + adjacent carriers) expressed in dBm.
RSV	Reed–Solomon error correction is an error-correcting code that works by oversampling a polynomial constructed from the data.

SCPC	Single Channel Per Carrier
Short frames	DVB-S2 frames 16200 bits long (including FEC). Advisable to use at lower symbol rates. Produce less delay than Long frames.
SNMP	Simple Network Management Protocol
SNTP	Simple Network Time Protocol (SNTP) is a protocol and software implementation for synchronizing the clocks of computer systems over packet-switched, variable-latency data networks.
SNR	Signal-to-noise ratio is an electrical engineering measurement defined as the ratio of a signal power to the noise power corrupting the signal.
SR	Symbol Rate
Star	Type of network with one central station (hub) and several peripheral stations.
SW	Software
TDM	Time Division Multiplexing
TDMA	Time Division Multiple Access
Telnet	Telecommunication Network (Telnet) is a network protocol used on the Internet or local area networks to provide a bidirectional interactive communications facility. Typically, telnet provides access to a command-line interface on a remote host via a virtual terminal connection.
Terminal	Earth Stations (usually VSAT) operated under management of network HUB
TFTP	Trivial File Transfer Protocol (TFTP) is a file transfer protocol, with the functionality of a very basic form of File Transfer Protocol (FTP).
Timestamp	Time format used by UHP. Plus sign at the beginning (+HH:MM:SS or +NN d HH:MM:SS)denotes relative time from some event or UHP start-up. If UHP has time synchronized to hub or SNTP absolute time can be displayed. Time zone affects absolute time.
Time-slot	Time interval for station transmission.
UDP	The User Datagram Protocol (UDP) is the set of network protocols used for the Internet. With UDP, computer applications can send messages, in this case referred to as datagram, to other hosts on an Internet Protocol (IP) network without requiring prior communications to set up special transmission channels or data paths.
USB	USB (Universal Serial Bus) is a specification to establish communication between devices and a host controller (usually personal computers).
VLAN	A virtual LAN, commonly known as a VLAN, is a group of hosts with a common set of requirements that communicate as if they were attached to the same broadcast domain, regardless of their physical location.
VoIP	Voice over Internet Protocol (VoIP) is a general term for a family of transmission technologies for delivery of voice communications over IP networks such as the Internet or other packet-switched networks.
VSAT	Very Small Aperture Terminal – satellite earth station with small-size antenna
WFQ	Weighted fair queuing. Method of proportional division of bandwidth between transmission queues.
X-modem	Simple file-transfer protocol

INTRODUCTION

This document presents a general description of the UHP-8000 series satellite routers and is intended for familiarization with the system capabilities and specifications. This manual describes all the key modes of the router operations.

Required level of qualification

This manual is intended for engineering personnel operating VSAT networks. Such specialists should have adequate educational credentials in the field of electronics and sufficient experience and skills in data networks administration and satellite systems.

Document version and applicability

UHP VSAT platform is based on the universal satellite router UHP, which is available in different fully-compatible hardware modifications. UHP satellite router is a basic element of any network architecture and can be used in any combinations and at any hierarchy level. Router functional capabilities and its operating modes are determined by the installed software and its configuration.

This manual is applicable to all UHP-8000 series satellite routers with software release 3.2 or higher. When ordering this document, please specify its ID: [UHP.8R32.EN].

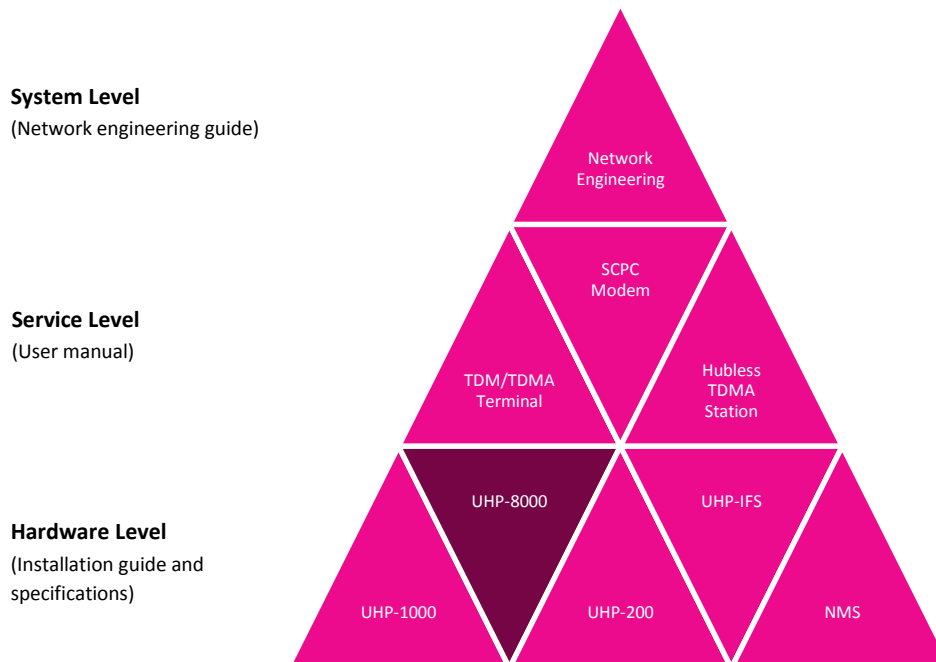

Figure 1 Structure of UHP Manuals

Copyright

The content of this document is the intellectual property of Romantis Inc. (referred to below as Romantis). Copying or quoting this description as a whole or of any part of it without a written permission from Romantis is prohibited.

1. GENERAL DESCRIPTION

1.1 System overview

1.1.1 Purpose

UHP satellite routers are essentially a universal solution for geographically distributed VSAT-class satellite communication networks. UHP routers can be used to organize simple point-to-point channels, “star”- and “mesh”-topology networks with several hierarchy levels and bandwidth-on-demand capabilities.

UHP-8000 dual satellite router is an integrated chassis with two UHP-1000 routers and IF subsystem that can be used as two independent routers or as elements of some complex system (e.g. Hub, redundant modules, etc.).

1.2 Router composition

UHP-8000 router consists of:

1. Integrated UHP-1000 satellite router “A”;
2. Integrated UHP-1000 satellite router “B”;
3. IF subsystem with combiner and divider;
4. Integrated power supplies (individual for each router);
5. 1U rack-mountable chassis

1.3 Measurement equipment, tools and accessories

Standard computer (notebook) is required to configure and monitor status of UHP-8000 satellite router. The computer must be equipped with a LAN interface and USB, and also have the following software installed:

- Internet browser (WEB browser)
- Telnet Client
- The Terminal (e.g.: Hyperterminal, included in the OS Windows) (optional)

The router can be accessed via LAN or USB ports. Standard USB AM/BM cable (not supplied) is required for connection to USB “Console” port of the satellite router.

Connection of a computer to the router via LAN interface is implemented through the Ethernet switch or hub via a standard network cable with RJ-45 connectors (not supplied).

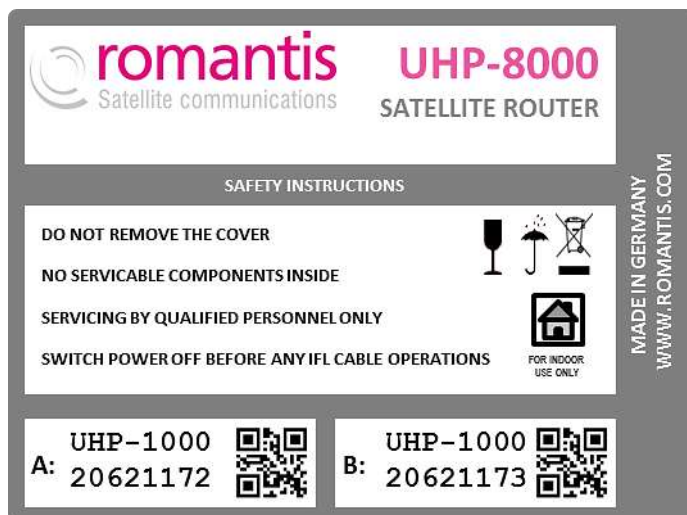

Figure 2: Standard labeling of satellite router

1.4 Labeling and sealing

The product is marked with the unique Serial Number on the bottom of the router’s case.

The warranty seals are located on the bottom of the product, at the junction of the two parts of the case. Product’s warranty will automatically void if such labels have been removed, modified or damaged.

1.5 Packaging and content

Satellite router comes as an integrated chassis. It is recommended to keep original packaging throughout the entire lifetime. Conservation, storage and transportation of the terminal must be in original packaging.

Standard package includes:

1. UHP-8000 dual satellite router
2. Power cables

1.6 Description and principles of operation



Figure 3: UHP-8000 satellite router – rear view

1.6.1 Overview

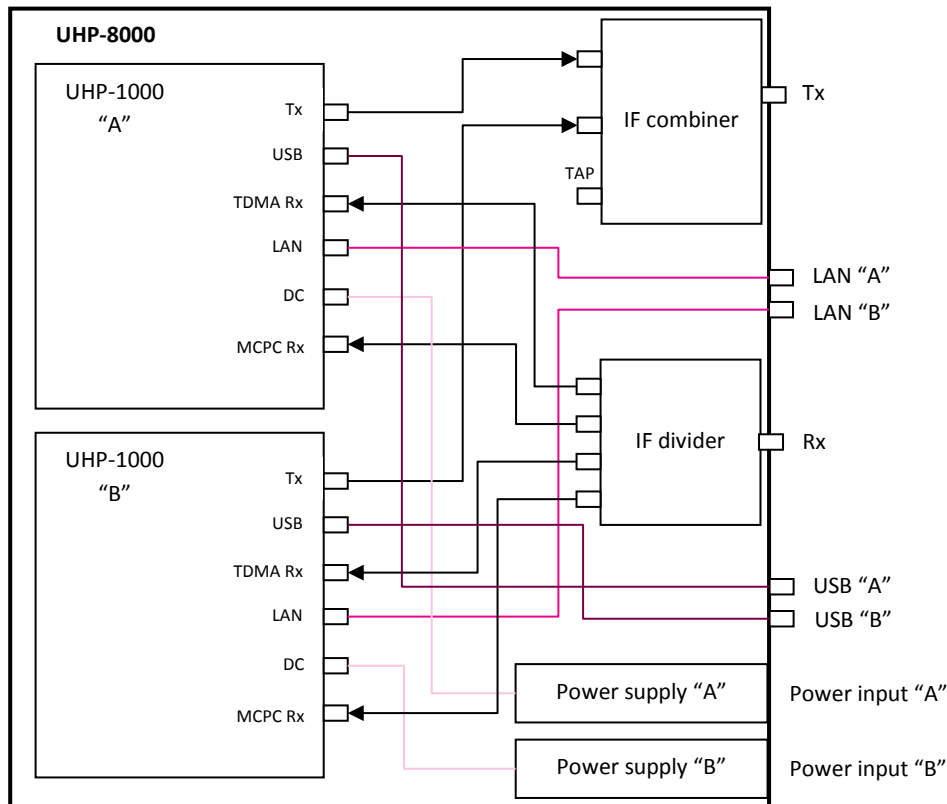

Figure 4 Standard internal configuration of UHP-8000 router

All the interfaces are located on the rear panel of the device. The indicators are located on the front panel. Indication of each integrated router is located on the front panel of the chassis and similar to the standard display of UHP- 1000 router. Indications on the left side of the front panel are related to the router "A", the indications on the right side correspond to the router «B». The LAN and USB interfaces of each router are located on the rear panel of UHP-8000 chassis and marked with «A» and «B», respectively.

USB PORTS MAY NOT BE AVAILABLE ON SOME VERSIONS OF UHP-8000 ROUTERS.

Depending on the ordered product's configuration (mode of operation), interconnectivity of internal modules can be configured with a different scheme. It applies only to connection of modulators and demodulators to interface module (IF divider and combiner).

In the basic configuration (Figure 4) outputs of the modulators are summarized on the IF combiner ("Tx" output). The IF combiner provides the transmission of IF signals, and can also transmit DC supply voltage and/or 10MHz frequency reference for a BUC. Input signal from the "Rx" input is divided and fed to the inputs of all the demodulators. The divider also provides a pass of DC and/or 10MHz reference frequency for LNB.

In HUB configuration (HBIC) (Figure 5) a high-speed demodulator of the satellite router "B" (acting as IC) is connected to a «TAP» output of the IF combiner ("Tx" output) that allows synchronizing the router "B" with the router "A" (acting as HB).

In dual Inroute configuration (ICIC) the "Tx" interface is used to input an Outroute signal from an external HB module. This signal is divided and distributed to each of the high-speed demodulators for synchronization (see Figure 6).

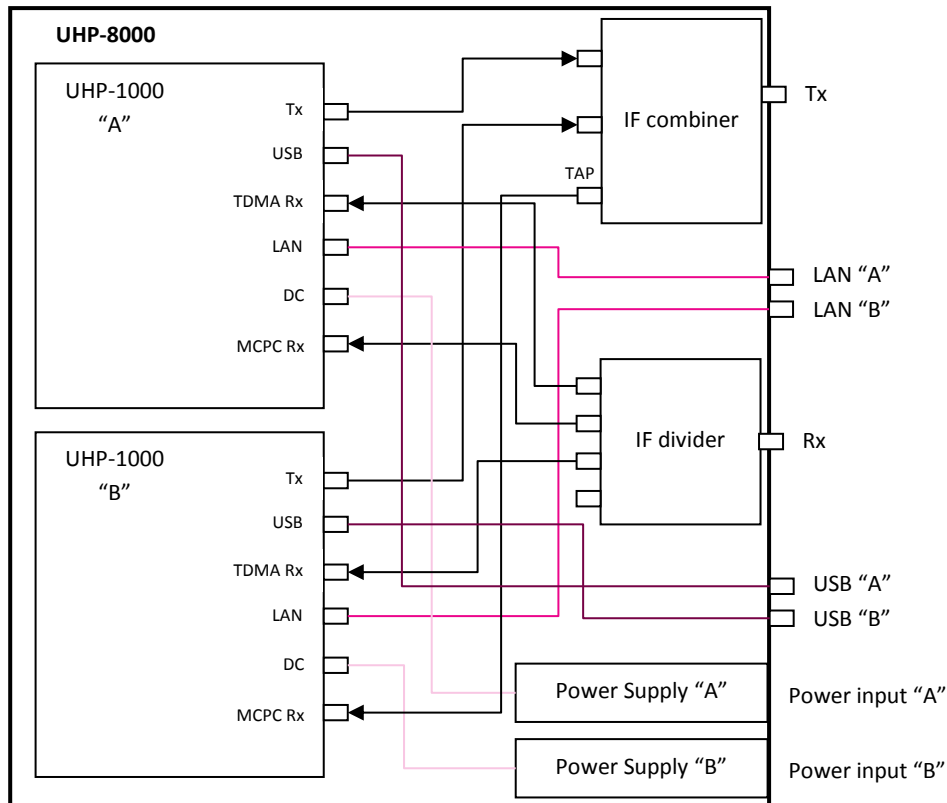

Figure 5 Internal configuration of UHP-8000 in Hub (HBIC) mode

1.6.2 Power connector (Power input A/B)

UHP-8000 router is powered with 100-240 VAC. UHP-8000 chassis has two independent power supplies (with individual AC inputs) for each of the router respectively.

1.6.3 USB CONSOLE (USB A/B)

USB console ports provide local control of each of the integrated routers.

1.6.4 IF input (RX)

The RX interface is an input of the divider that distributes signals to the demodulators (see also 0). The router may feed this input with 18 VDC power supply. Whether power source is on or off, the input can withstand external

voltage up to 50 VDC (power supply circuit is provided with a diode). Power supply circuit is protected with a thermal fuse operating in case of short circuiting. After short circuiting is removed it may be required to disconnect load from the Rx input for several seconds so as to allow the fuse to return to its initial state. Cable length and cable quality (losses level) can affect the quality and possibility of receiving signals.

THE TOTAL CURRENT CONSUMED BY EXTERNAL EQUIPMENT SHOULD NOT BE IN EXCESS OF 750 mA. NORMALLY, CURRENT CONSUMPTION BY DRO LNB - <150 mA, PLL LNB - <500 mA.

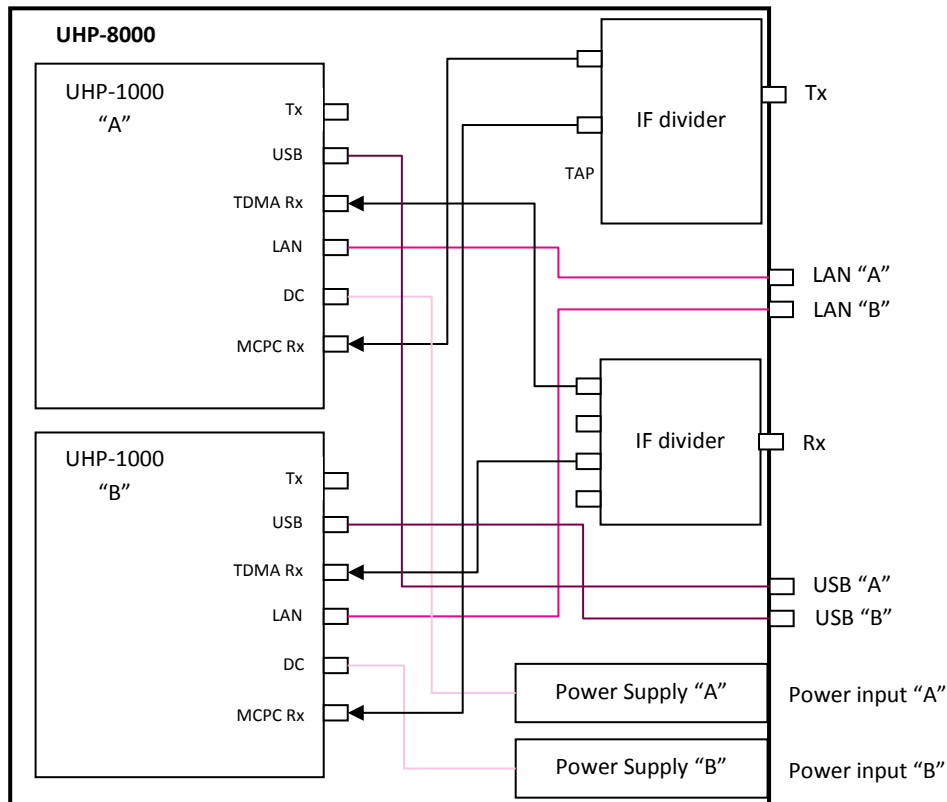

Figure 6 Internal configuration of UHP-8000 in dual Inroute (ICIC) mode

1.6.5 LAN interface connector (LAN A/B)

LAN connectors are purposed for connecting to Ethernet switch using a straight cable. These connectors are connected directly with respective LAN outputs of the integrated routers. Bit rate 10 or 100 and duplex mode are software selectable.

1.6.6 Modulator output (TX)

TX OUT OUTPUT CAN FEATURE 24 VDC WITH A HIGH SHORT-CIRCUIT CURRENT. SHORT CIRCUITING CAN CAUSE SPARKLE SPREAD AND BURNS. THIS VOLTAGE CAN DAMAGE MEASUREMENT EQUIPMENT IF IT IS NOT PROTECTED AT ITS INPUTS. SUPPLYING EXTERNAL VOLTAGE TO THIS CONNECTOR IS OBJECTIONABLE . SUPPLYING MORE THAN 24 V IS PROHIBITED.

The purpose of "Tx" interface depends on the factory-selected Tx mode of operation (see 0). The interface provides transmission of IF signals, 10 MHz reference and 24 VDC power supply (if activated on the router).

WARNING! THE SUPPLY VOLTAGE AND THE REFERENCE SIGNAL SHOULD BE ACTIVATED ONLY ON THE ONE OF THE ROUTERS!

UHP-8000 modulators are compatible with most satellite transmitters/converters (BUC), except that require to explicit "TX On" FSK command.

UHP-8000 is not provided with a separate protection on the transmitter power supply circuitry. Use is made of current protection for the power supply adapter. In case of a short circuit the router is de-energized and then gets restarted. If power supply is switched on in the configuration, restarts continue at 5 second interval until short circuiting is removed.

ANY OPERATIONS WITH IF TX CABLE SHOULD BE PERFORMED WITH 24 V SUPPLY VOLTAGE TURNED OFF. OTHERWISE, SELF-INDUCTION ACROSS A LONG CABLE CAN DAMAGE THE TRANSMITTER AND/OR ROUTER.



Figure 7 Satellite Router UHP-8000 series front view

1.6.7 “ERROR” Indicator

“ERROR” red indicator makes it possible to infer about problems in the router functioning. The type of the generated problem can be judged by the number of indicator flashes:

1. Demodulator cannot receive MCPC channel from the Hub (other Terminal). Please check AGC value in the demodulator statistics to determine whether there is a signal from antenna (see description of reception problems) to separate LNB and cable faults.
2. Router cannot receive TDMA configuration from the HUB (TDM/TDMA network mode). The reason can be in the non-availability of receiving channel from the HUB, CRC errors during reception, wrong configuration of the Terminal.
3. Router cannot calculate time shift with respect to the HUB. The reason can be in the non-availability of reception or a large number of CRC errors during reception.
4. HUB cannot receive signal from this terminal. Please check transmit signal level of the terminal, whether power supply and the reference signal for the transmitter are switched on (or off if required), whether DTTS or geographical coordinates are set correctly in the TDMA settings.
5. Unit is in Backup state of Redundancy mode. Not an error.

Continuous signal means that the router has hardware or configuration errors. If ERROR indicator is continuously lit upon power on it means hardware failure of UHP occurred. That prevents software from starting. Try to power it off and power on again.

1.6.8 “STATUS” Indicator

“STATUS” green indicator indicates the router’s operation mode. This indicator is always flashing. If it does not flash it means that the router is not functioning (please check power supply). Slow flashing (once every second) means router’s normal operation. Faster flashing (3 times every second) means that a Telnet remote control session is established (in this case USB console does not operate until session is over).

Fast (6 times every second), simultaneous flashing of “ERROR” and “STATUS” indicators means that the router is functioning with the factory default configuration. Access to the router in this mode is possible either via USB or via IP-address 192.168.222.222 (mask 255.255.255.248 or /29).

1.6.9 “LOCK” Indicator

“LOCK” green indicator indicates whether the router receives a channel from the central station. If there are CRC errors during reception of information from the channel (e.g. with weak signal from the antenna), the indicator extinguishes for a fraction of a second at every error. If there are too many errors the indicator may not glow at all in spite of the fact that the router receives the channel (in this case please check the router demodulator statistics).

1.6.10 “TDMA” Indicator

“TDMA” yellow indicator flashes every time a TDMA data packet is received via RX interface.

1.6.11 “SCPC” Indicator

“SCPC” yellow indicator flashes every time a SCPC data packet is received via RX interface.

1.6.12 “TX” Indicator

“TX” yellow indicator flashes every time a data packet is transmitted in the MCPC mode, and also a blank packet – in the TDMA mode (if no data is available for transmission).

2. OPERATIONS

2.1 Operational limits

Table 1 Operational limits

#	Parameter	Limits	
		Minimum	Maximum
1	PSU Input voltage	100 VAC	240 VAC
3	Output current at Tx Out interface	-	2 A
4	Input voltage on the Tx Out interface	-	24 V
5	Output current at Rx SCPC or RX TDMA	-	0,75 A
6	Input voltage on other interfaces		18 V
7	Operational temperature	0 C	+40 °C
8	Relative humidity (@ 25°C)	0%	90%
9	Atmospheric pressure (mm Hg)	720	770
10	Mechanical impacts (acceleration with an amplitude not exceeding 1,25 mm): - in a range 0,5 – 15 Hz: - in a range 15-40 Hz: - in a range 40-300 Hz:		2,45 m/s 5,88 m/s 14,7 m/s

2.2 Preparation for use

2.2.1 Unpacking

Before opening the packaging please check the safety of a transport container. If there is any visible damage of packaging you should keep it as long as the delivered equipment will be properly tested.

Unpack the router in the following order:

1. Extract from a cardboard box the router and power cord.
2. Store all packing materials for further storage or shipment of equipment.
3. Check equipment for the presence of any possible damage resulting from transportation.
4. Check the completeness of supply in accordance with the packing slip.

2.2.2 Installation

UHP-8000 Router is designed for installation in a 19" telecommunication rack or on a suitable flat surface.

Make sure you have enough free space for ventilation of the power supply and the router (not less than 2 cm). While installing the router inside the computer or other systems we recommend using forced cooling to guarantee the normal thermal environment of the router.

2.2.3 Connecting to external devices

All wire connections must be performed before powering up the router. IF cable connectors should be screwed to the router without any use of any mechanical instruments. Please, avoid excessive force while connecting IF cables.

WARNING! DO NOT CONNECT OR DISCONNECT ANY CONNECTING CABLES TO THE ROUTER WITH THE POWER ON. THIS CAN LEAD TO A FAILURE OF THE ROUTER AND CONNECTED DEVICES.

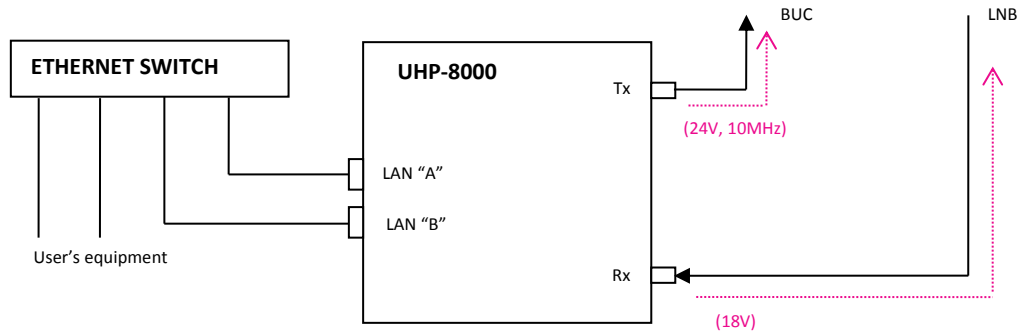

Figure 8 Example of router's connection in a basic mode of operation.

Typically, the router UHP-8000 is connected to individual RF frequency equipment (ODU). In such configuration IF output of the modulator is connected to the power amplifier BUC, and the input of high-speed demodulator to LNB. The router will supply the BUC with 24V power and 10MHz reference signal. Also, the router may provide LNB with 18V DC power. The user's equipment should be connected to the router via Ethernet switch or hub, if you plan to connect only one device, it can be connected directly with Ethernet cross-over cable.

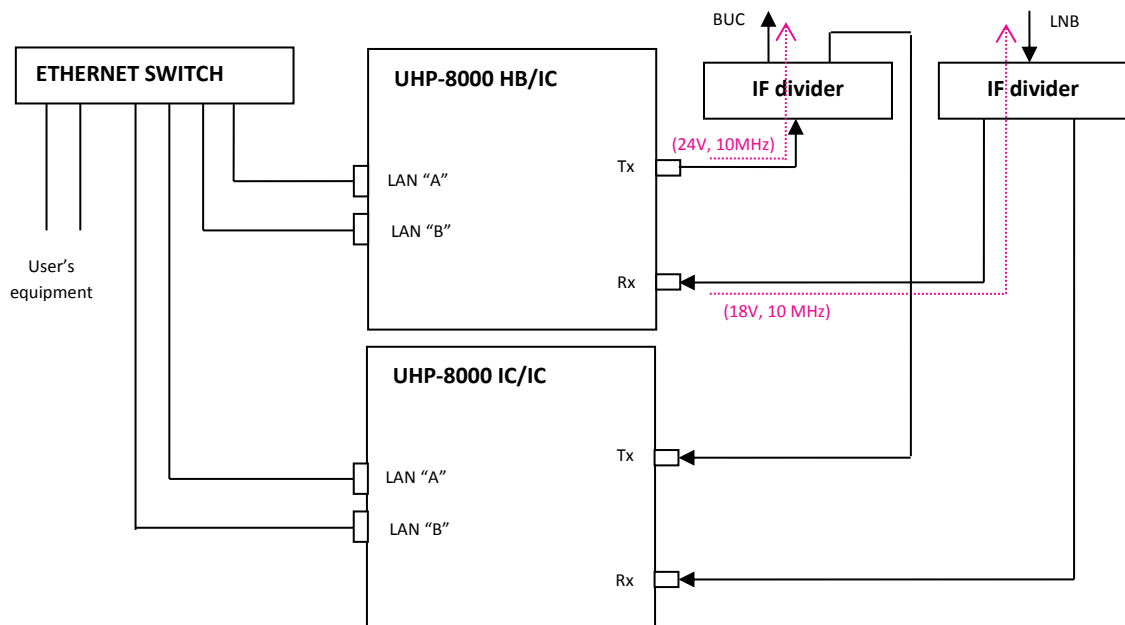

Figure 9 Example of router's connection in Hub mode (with 3 Inroutes)

In the Hub mode with several chassis (HBIC+ICIC) Rx inputs and Tx of these routers outputs should be connected to RF equipment via IF dividers as it is shown on the Figure 9. Such dividers have to ensure by-pass of DC and 10 MHz reference signal.

2.2.4 Powering on

In a few seconds after powering the router it is ready for use. Readiness of the router will be confirmed by "STATUS" LED indicator (blinking with a period of 1 second), as well as by single flashes of "ERROR" indicator, meaning a lack of reception of the receiving carrier.

With factory setting the router is configured as TDM/TDMA terminal. The router requires change of mode of operation (if necessary) and/or configuration of respective network parameters before login into satellite networks.

The easiest way to configure the router is using its HTTP access via its LAN port.

2.2.5 Local access to router via HTTP interface

HTTP (WWW) interface allows configuration key parameters and monitoring its actual status of the router. Local Web page of the router can be accessed from any Internet browser.

By default, UHP-8000 router is configured with IP-address 192.168.222.222 with mask 255.255.255.248 (/29). Respectively, the computer should be configured with an address, e.g. 192.168.222.217 with the same mask.

In case the satellite routers have been preconfigured at the factory on customer's request such routers may have different default IP address. In such case the respective IP addresses will be listed in the passport of the router. If it's impossible to connect the router with any of specified addresses please reset the router to factory settings.

2.2.6 Local access via USB

When router is connected to a computer via a USB cable the computer creates a serial COM port. The port number can be found in the Device Manager. To access the port use can be made of either the OS-integrated terminal (Hyperterminal) or third-party terminal programs.

With the first connection of UHP-8000 Router to PC the system may request the device's driver (not required for Windows 7 and newer OS). UHP.INF driver can be downloaded from our web site.

While working with the port from the terminal program the data rate and control parameters can be set to any value since they are ignored.

WITH USB OS PROTOCOL STACK – THERE IS A PECULIARITY WHICH LEADS TO “HANGING” OF THE USB-PORT IF IT CARRIED AN ACTIVE SESSION AND THE CONNECTED DEVICE (ROUTER) AT THIS MOMENT WAS REBOOTED. IN THIS CASE YOU HAVE TO LOG OUT FROM THE TERMINAL PROGRAM AND LOG IN AGAIN. YOU CAN AVOID THIS BY CUTTING OFF THE SESSION BY “HANG-UP” COMMAND AND ONLY THEN RESTART THE ROUTER USING RESET BUTTON OR VIA POWER SUPPLY CIRCUIT.

2.2.7 Remote Telnet access

Remote access to the configuration can be performed using Telnet protocol. The connection can be provided to any of IP addresses that are set on the router. UHP-8000 supports simultaneously only one Telnet session The router auto-terminates the session after a certain time of inactivity. The time can be set in the configuration. by default it is 10 minutes.

2.2.8 Command Interface

Please refer to the Command Interface manual applicable for the respective version of SW and activated mode of operation of UHP router. The Command Interface manuals are available for download and online use on Romantis website: <http://www.uhp.net/en/support/docs>.

3. OPERATIONS

UHP Routers belong to the class of unattended equipment and during its operation does not require any special staff exploitation. When operated as SCPC station or TDM/TDMA terminal the satellite router does not require any changes of settings or it is configured remotely from the Hub. The tasks of operational staff are limited to the following:

- Monitoring of climatic environment of operation, ensuring the absence of dust, preventing the ingress of moisture on the surface of the device. Should provide unrestricted air access to router for cooling.
- Cables connected to the device must not suffer any significant impact on the connections of the router. All connectors must be properly attached and secured.

3.1 Software updates

One of the key advantages of UHP satellite routers is the ability to extend the functionality by updating the software. Software updates also include fixes for known bugs and improving the algorithms of the system.

3.2 Powering off

To power the router off the Power Supply should be disconnected from AC power. If the device is powered by a low-voltage DC source, it can be powered off by disconnecting the DC cord from DC IN connector of the router.

3.3 Safety instructions for operations

- ☞ Connect and disconnect all the cables only when router is powers off;
- ☞ Do not block ventilation holes of the router, as this could lead to overheating of the device;
- ☞ Clean the router by dry cloth, do not use liquid wipes or cleaners;
- ☞ Router must be installed on a stable and flat surface;
- ☞ Do not install on or nearby the router any glasses, vases and other containers containing liquid;
- ☞ Do not try to repair the router and do not use it for other purposes;
- ☞ There are no serviceable components inside, opening a case is not permitted;
- ☞ Servicing by qualified personnel only;

3.4 Actions in case of fire

In case of fire or any smoke of the router please immediately power off the device and if necessary, use extinguishing tools that are intended for electrical circuits.

4. TROUBLESHOOTING

Table 2 Troubleshooting guide

Symptoms	Possible reasons	Actions
Router doesn't work	AC power beyond the limits of allowed values	Check AC power voltage
	Power cord is broken	Check PSU cables and output voltage of PSU. Replace a cable.
	Power Supply failure	Check PSU cables. Verify if output DC Voltage is in nominal range. Replace PSU module
	Router Failure	Check PSU cables. Contact your nearest dealer or service center for advanced support.
ERROR indicator lights constantly after power on.	Router can't start the software	Power off and power on the router. Contact your nearest dealer or service center for advanced support.
Router restarts every 3-5 seconds.	Short-circuit in transmit cable	Disconnect and check Tx cable
	Software failure	Reset software to factory defaults
No reception from the satellite (indicator LOCK is off, single flashes of ERROR indicator)	Incorrect configuration	Check Rx frequency and symbol rate.
	IF cable failure	Check Rx cable and make sure that its connectors are properly connected to the LNB and the router.
	LNB is not powered	Check if LNB power is switched on Disconnect Rx IF cable from LNB and make sure that 12-18 VDC is available on the connector. Check Rx level in the statistic of the demodulator.
	No carrier on the satellite or its level is insufficient.	Verify availability of the carrier and its level with spectrum analyzer. Contact Hub administrator and investigate if the carrier is properly transmitting and local weather conditions not attenuate the signal.
	Low Rx carrier level	Measure carrier signal to noise level with a spectrum analyzer. Verify if antenna is properly pointed to the satellite and there are no obstacles in the direction to the satellite. Check the integrity of the film of antenna's feed horn and absence of moisture in it.
High rate of errors of Rx path (LOCK indicator is not lighting constantly)	LNB failure	Replace LNB to the spare one
	Bad weather conditions	The quality of reception may temporary decrease during intensive rainfall, fog or thunderstorm cloudiness. Check if there is no snow or ice on the antenna surface and on the feed horn.
	Low signal to noise level	Check C/N in demodulator's statistics. Verify if antenna is properly pointed to the satellite and there are no obstacles in the direction to the satellite. Check the integrity of the film of antenna's feed horn and absence of moisture in it.

Symptoms	Possible reasons	Actions
	Low Rx carrier level Interferences	Check Eb/No in demodulator's statistics. Contact Hub administrator and investigate if the carrier is properly transmitting and local weather conditions do not attenuate the signal
Station is not transmitting (Reception is normal: LOCK indicator is lighting, but TX indicator is off)	Wrong network setting	Check Tx frequency and symbol rate of the modulator. Make sure that transmission is enabled
	Transmission of the terminal is not allowed by Hub (only for TDM/TDMA terminal)	Contact Hub administrator
Station is not transmitting (Reception is normal: LOCK indicator is lighting, TX indicator is blinking, but transmission is not received by Hub/opposite station)	IF Tx cable failure	Check Tx cable and make sure that its connectors are properly connected to the BUC and the router.
	BUC is not powered	Check if BUC power is switched on Disconnect Tx IF cable from BUC and make sure that 24 VDC is available on the connector.
	BUC failure	Replace the BUC on the spare one
Other symptoms	Other reasons	Contact your dealer or service center

In many cases, reinstalling system software allows to restore a satellite router functionality, which may need reset to the factory default configuration. If the recovery of software cannot be implemented successfully, or if this operation does not eliminate the defect, it is necessary to illuminate the faulty device and replace it by new device.

4.1 Replacement of modules

4.1.1 Common recommendations

Repair of satellite router is carried out by replacing defective units (PSU or a router) or the whole product.

Replacement must be carried out only on original and compatible units, supplied by the manufacturer. After replacing the power supply the router is immediately ready for further operation. In case of a satellite router replacement it has to be reconfigured to the network parameters in accordance with Section 2.2.

4.1.2 Safety instructions

Repair by replacing blocks of satellite router must be carried out by qualified personnel only and with powered off device only.

5. STORAGE, TRANSPORTATION AND DISPOSAL

Storage and transportation of satellite routers must be performed in original packaging. Equipment can be stored and transported in pallet with height not more than 10 devices.

Storage and transportation should comply with the following conditions:

- - humidity is not more than $(80 \pm 3)\%$ at a temperature $(25 \pm 2)^\circ\text{C}$;
- - limiting low temperature of storage $(\text{minus } 40 \pm 2)^\circ\text{C}$;
- - limiting high temperature of storage $(50 \pm 2)^\circ\text{C}$.
- - atmospheric pressure $720 \div 770$ mm. Hg.

Utilization of satellite routers must be in accordance with the rules for disposal of industrial or consumer electronics in accordance with applicable law.